



Colletotrichum species and complexes: geographic distribution, host range and conservation status

Pedro Talhinhos¹ · Riccardo Baroncelli²

Received: 22 December 2020 / Accepted: 1 September 2021
© MUSHROOM RESEARCH FOUNDATION 2021

Abstract

The taxonomy of the genus *Colletotrichum* has undergone tremendous changes over the last decade, with over 200 species being currently recognised and species complexes being informally used to cluster those species. Many of these species are important plant pathogens, some rather polyphagous and others host-specific, but several occur seldomly and some may in fact be ecologically endangered. Based mainly on literature from the past decade, in this work we review the occurrence, geographic distribution and host spectrum of currently recognised *Colletotrichum* species under phylogenetic, pathological/agronomic and ecological perspectives, providing a list arranged by *Colletotrichum* species and species complexes. A total of 257 species are listed and grouped into 15 species complexes. In this work we have recorded 1353 unique host species-*Colletotrichum* species association records from 720 hosts, with the Fabaceae as the family with higher number of hosts (52 host species) but with the Rosaceae as the family with the highest number of host species-*Colletotrichum* species association records (118 association records). According to occurrence data, 88 species are common in nature, 128 were considered as data deficient and 41 are threatened, some of which are likely extinct from nature and preserved only in culture collections. Several species are relevant plant pathogens, in some cases geographically confined and thus of potential quarantine relevance. Based on the major changes that occurred on *Colletotrichum* taxonomy over the last decade, this work provides a comprehensive overview of occurrence data of *Colletotrichum* species, compiling host range and geographical distribution, with relevance for plant pathology and conservation mycology. The current taxonomic framework in *Colletotrichum* is revealing numerous species but poses challenges to the employment of standard criteria for the evaluation of biological conservation of these fungi. We advocate that conservation mycology and taxonomy should find common routes simultaneously enabling the correct delimitation of species of *Colletotrichum* and the implementation of feasible criteria for the evaluation of conservation. The employment of new technologies, such whole genome sequencing (WGS), will help and support the description of new species and to gain a better understanding of the genetic bases of speciation processes.

Keywords *Colletotrichum* · Species complex · Taxonomy · Host range · Geographic distribution · Conservation mycology

Colletotrichum taxonomy and importance

Many species belonging to the genus *Colletotrichum* are implicated in plant diseases, generally referred to as anthracnose, on a wide range of hosts, and these pathogens are characterised by a worldwide distribution and global relevance (Dean et al. 2012). Common hosts include many dicotyledonous plants such as strawberry, apple, citrus, and stone fruits, and major cereals such as maize and sorghum. Diseases on ferns and pines have also been reported. Anthracnose symptoms include dark necrotic lesions, which are oval or angular. Plant parts can be superficially affected at all stages of development, from seedlings to mature plants. Various *Colletotrichum* species are also important post-harvest

Handling Editor: Lei Cai.

✉ Pedro Talhinhos
ptalhinhos@isa.ulisboa.pt

¹ LEAF—Linking Landscape, Environment, Agriculture and Food—Research Centre, Associated Laboratory TERRA, Instituto Superior de Agronomia, Universidade de Lisboa, Tapada da Ajuda, 1349-017 Lisbon, Portugal

² Department of Agricultural and Food Sciences (DISTAL), University of Bologna, Bologna, Italy

pathogens due to their ability to undergo a non-pathogenic phase (Bailey and Jegger 1992). *Colletotrichum* species are characterised by a distinctive hemibiotrophic lifestyle (also known to occur in other fungal species, e.g. *Magnaporthe*). Fungi belonging to this genus initially infect through a brief biotrophic phase, associated with large intracellular primary hyphae. The fungus later switches to a necrotrophic phase, associated with narrower secondary hyphae that spread throughout the host tissue (De Silva et al. 2017b). Biomolecular processes that regulate this lifestyle have long been studied by the scientific community, especially those related to the switch from biotrophy to necrotrophy (O’Connell et al. 2012). Beside the economic impact of *Colletotrichum* species, this genus encompasses a wide diversity of important traits such as host range and host preference, mode of reproduction and differences in the strategy used to infect their hosts. In addition to being plant pathogens, *Colletotrichum* members can be plant endophyte and growth promoters, entomopathogens and opportunistic human pathogens. The genus contains a tremendous biological diversity within a group of closely related species, and this makes it a perfect model to study the molecular and genetic factors associated with biological traits.

The most recent formal description of the genus *Colletotrichum* is given by Jayawardena et al. (2020), providing, along with Marín-Felix et al. (2017), notes on morphology and cultural characteristics and information on standardised media and cultivation conditions. *Colletotrichum* was established in 1837, by Corda (Sutton 1992). Von Arx (1957) thoroughly revised the genus, reducing around 750 species to 11 taxa, which gradually increased. In 2000 the number of species was updated with morphological, cultural and pathogenicity studies and around 40 were accepted (Cannon et al. 2000). *Colletotrichum* species are mainly asexual, but some have a teleomorph that can be either homothallic or heterothallic. The MAT1-1/2 system in *Colletotrichum* species is not typical as that in most ascomycetes, as *Colletotrichum* fungi are capable of sexual reproduction while using only the *MAT1-2-1* gene (Menat et al. 2016; Liang et al. 2021; Wilson et al. 2021). The genus *Colletotrichum* is the single genus in the Glomerellaceae family. Other members of the Glomerellales, namely in the families Australiascaceae, Reticulascaceae and Plectosphaerellaceae (Réblová et al. 2011; Giraldo and Crous 2019), are far less frequently reported, with *Colletotrichum* representing over 78% of the occurrences of Glomerellales recorded in GBIF database (www.gbif.org).

The advent of molecular systematics, at first based on ITS, and subsequently on multilocus sequence typing (MLST) approach, has accelerated the elucidation of phylogenetic relationships of *Colletotrichum* members. ITS is generally used to resolve species complexes within the genus (Jayawardena et al. 2016a; Marín-Felix et al. 2017). ITS is also sufficient to identify some species in the genus (e.g. *C. graminicola* and species in the *gigasporum* complex; Liu et al. 2014; Cuevas-Fernández et al.

2019). However, the delimitation of most *Colletotrichum* species requires additional use of a combination of sequences from some of the *act*, *ApMat*, *apn2*, *cal*, *chs-1*, *gapdh*, *gs*, *his3*, *sod2* or *tub2* genes (Jayawardena et al. 2016a, 2020, 2021; Marín-Felix et al. 2017). In fact, *Colletotrichum*, along with genera such as *Alternaria*, *Aspergillus*, *Cladosporium*, *Fusarium* and *Penicillium*, is recognised as an example of insufficient resolution of ITS for species delimitation (Lücking et al. 2020). However, the usefulness of such additional genes varies strongly in different species complexes in the genus (Jayawardena et al. 2016a). The *ApMat* gene shows high resolution to distinguish species in the gloeosporioides complex, but it has been of little or no use in other complexes (Silva et al. 2012b; Sharma et al. 2015). In this study the phylogeny of *Colletotrichum* is constructed (Fig. 1) using the type strains of 252 species and five genetic loci (*act*, *chs-1*, *gapdh*, ITS and *tub2* (Supplementary data 1, ‘sequences’ tab)).

Accepted species of *Colletotrichum* and species complexes

As of June 2021, Index Fungorum lists 928 taxa in the genus *Colletotrichum*, 806 at the rank of species and the remaining 113 as diverse infra-specific taxa, mostly at the *formae* and *varietas* ranks. *Colletotrichum lineola* was the first species described in the genus, in 1831. The vast majority of *Colletotrichum* taxa (638 taxa) was described between 1888 and 1975 (Fig. 2), representing on average 7.3 taxa per year. One taxon per year was described on average in the 1976–2008 period, but since 2009 another 230 taxa were described (228 species; 18.3 taxa per year on average, peaking in 2012 with 58 taxa).

Literature published in the past 10 years (approximately 800 articles, of which 353 are Plant Disease Notes published in the journal Plant Disease) were scrutinised for occurrence data of *Colletotrichum* species. Occurrence data was only recorded when species names were unambiguous according to modern criteria, namely considering the literature that defined and delimited each complex: *acutatum* (Damm et al. 2012a); *agaves* (Bhunjun et al. 2021); *boninense* (Damm et al. 2012b); *caudatum* (Crouch 2014); *dematium* (Cannon et al. 2012); *destructivum* (Cannon et al. 2012); *dracaenophilum* (Damm et al. 2019); *gigasporum* (Liu et al. 2014); *gloeosporioides* (Weir et al. 2012); *graminicola* (Cannon et al. 2012); *magnum* (Damm et al. 2019); *orbiculare* (Cannon et al. 2012); *orchidearum* (Damm et al. 2019); *spaethianum* (Cannon et al. 2012); *truncatum* (Cannon et al. 2012). Previous check-lists were also considered (Jayawardena et al. 2016a, 2021; Marín-Felix et al. 2017). Fungal names were checked and used following Index Fungorum (www.indexfungorum.org). Similarly, plant names were checked and used according to Plants of the World Online (www.plantsoftheworldonline.org). Occurrences were recorded on a table, under the following parameters: fungal species; host

Fig. 1 Phylogeny of *Colletotrichum* species and complexes. Maximum-Likelihood Tree obtained by FastTree2 v2.1.10 (Price et al. 2010) reconstructed from *act*, *chs-1*, *gapdh*, *ITS* and *tub2* sequence alignment of 253 reference isolates including the outgroup. The alignment was performed with MAFFT v7.450 (Katoh and Standley 2013), exported to MEGA7 (Kumar et al. 2016) and the best-fit substitution model calculated. The Markov chain Monte Carlo (MCMC) algorithm was performed to generate phylogenetic trees with Bayesian posterior probabilities for the alignment. Four MCMC chains were run simultaneously for random trees for 5,000,000 generations and sampled every 500 generations. The first 25% of trees were discarded as burn-in phase of each analysis and posterior probabilities were determined from the remaining trees. Bayesian posterior probability (obtained with MrBayes 3.2.6; Ronquist et al. 2012) and FastTree support values above 0.50/50 are reported next of the node; thicker branches represent node with BPP = 1.00 and ML = 100. The scale bar represents the number of expected substitutions per site. The tree is rooted with *Monilochaetes infuscans*. GenBank accession numbers are listed in Supplementary file 1. Information of each species such as host range, number of reported occurrences (O), number of reported host species, O/HS ratio, level of endanger and complexes are reported on the right

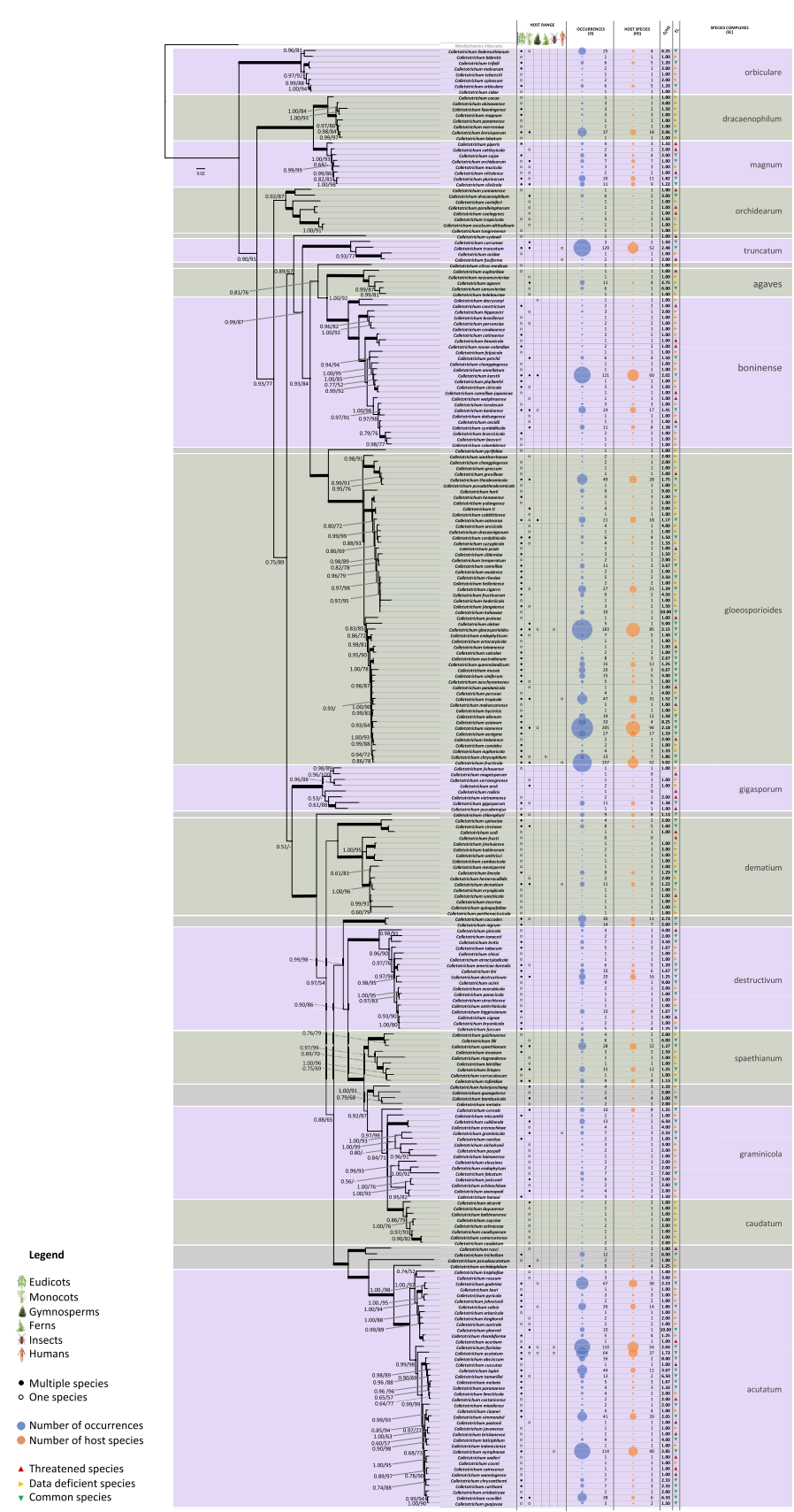
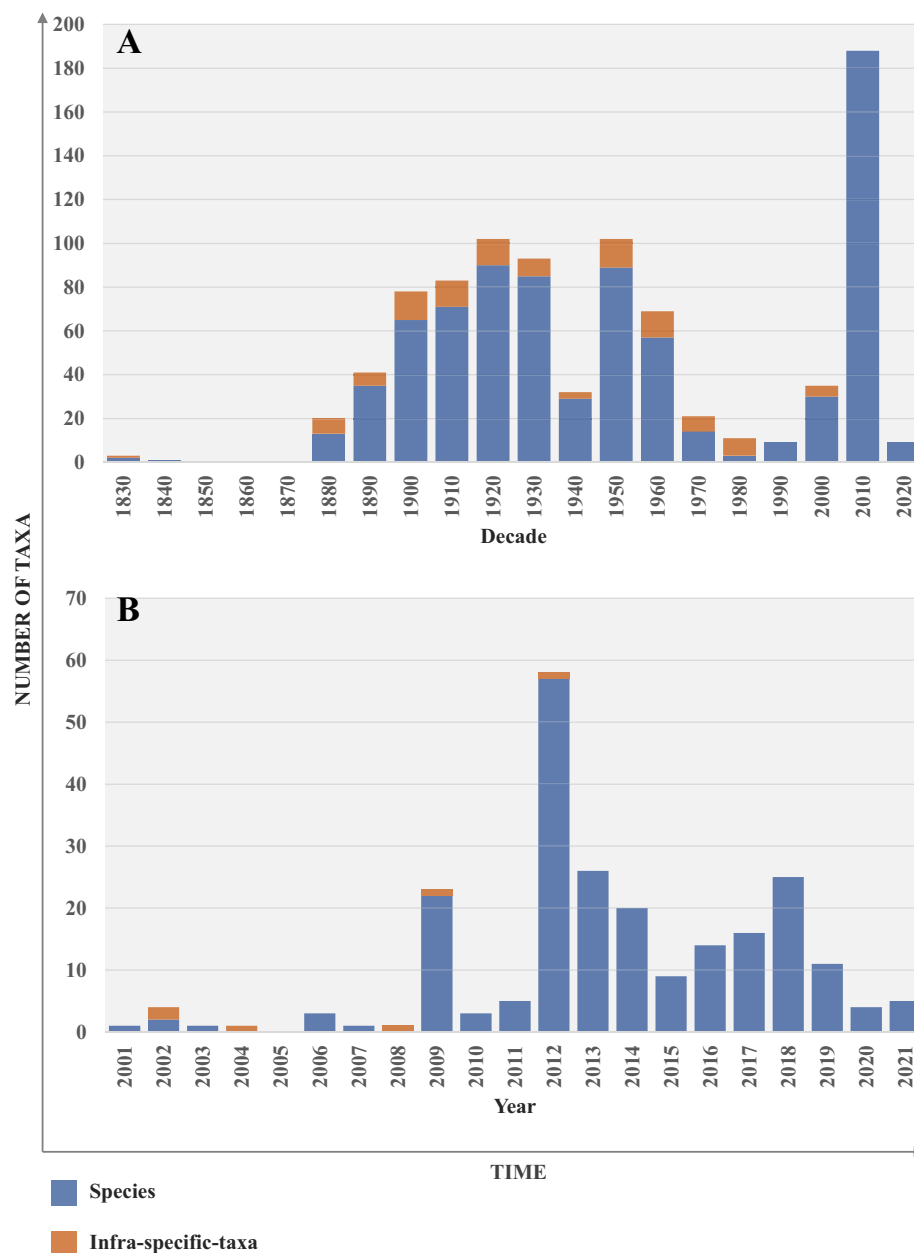

Fig. 2 Number of *Colletotrichum* species and infra-specific taxa recorded in Index Fungorum according to the year of publication since 1831 by decade (panel A) and since 2000 by year (panel B)



species (and type of interaction, when known); location; date; reference. Location information was used for georeferencing, as previously described (Talhinhas et al. 2019) and occurrence maps were prepared using MapChart (<https://mapchart.net>).

Adapting as much as possible the criteria defined by Dahlberg and Mueller (2011) for Mycological Conservation and considering also Blackwell and Vega (2018), we considered as threatened the species identified once or very few times and that were identified either in conditions that impair conducting surveys (e.g., identified on hosts that are not clearly defined, such as hosts with no species given) or on hosts that are recurrently subject of surveys (e.g., chilli, citrus, coffee, mango, strawberry) from which other species of *Colletotrichum* are recorded instead.

Other species seldomly reported were considered as 'data deficient'. Species recorded from multiple hosts and/or locations were considered as common.

The acutatum species complex

Before the massive use of genetic information in taxonomy, *Colletotrichum acutatum* was considered as a single but morphologically and phylogenetically diverse species (Lardner et al. 1999), originally described from diseased tissues of *Carica papaya*, *Capsicum frutescens* and *Delphinium ajacis* in Australia by Simmonds (1965). Due to the high diversity of *C. acutatum*, several intra-specific groupings were established based

on morphological, physiological, sexual, and molecular data (as revised by Sreenivasaprasad and Talhinhas 2005). Gradually, separate species were recognised as part of the acutatum complex, e.g. *C. lupini* (Nirenberg et al. 2002), *C. phormii* (Farr et al. 2006), *C. simmondsii* and *C. fiorinia* (Shivas and Tan 2009). The revision of the taxonomy performed by Damm et al. (2012a) was a landmark in the classification in which thirty-one species were accepted as member of the acutatum complex, of which 21 were newly described. To date, 41 species have been described (Fig. 3).

In phylogenetic terms (Fig. 3), the acutatum species complex can be divided in six clades with some degree of geographic structure. Whereas the lupini clade (comprising *C.*

abscissum, *C. costaricense*, *C. cuscutae*, *C. limetticola*, *C. lupini*, *C. melonis*, *C. paranaense* and *C. tamarilloi*) shows clear evidence of neotropical origin (in spite of the global distribution of *C. lupini*), fungi in the nymphaeae clade (comprising *C. brisbanense*, *C. cairnsense*, *C. carthami*, *C. chrysanthemi*, *C. cosmi*, *C. eriobotryae*, *C. guajavae*, *C. indonesiense*, *C. javanense*, *C. laticiphilum*, *C. miaoliense*, *C. nymphaeae*, *C. paxtonii*, *C. scovillei*, *C. simmondsii*, *C. sloanei*, *C. walleri* and *C. wanningense*) occur mostly in Asia and Oceania (in spite of the global distribution of *C. nymphaeae*) and those in the godetiae clade (comprising *C. acerbum*, *C. arboricola*, *C. australe*, *C. godetiae*, *C. johnstonii*, *C. kinghornii*, *C. lauri*, *C. phormii*, *C. pyricola*, *C.*

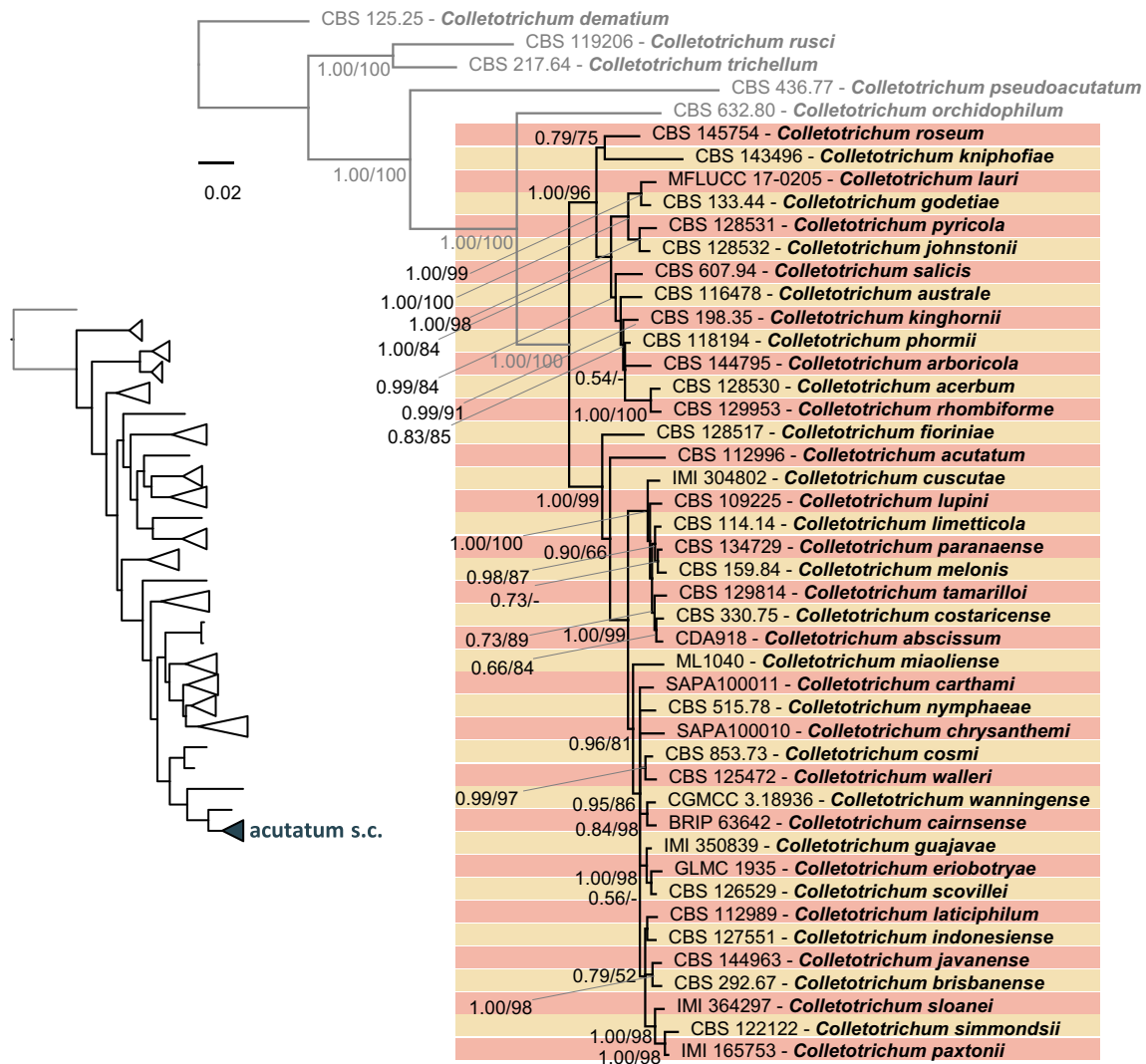

Fig. 3 Bayesian inference phylogenetic tree of the acutatum species complex and closely related singleton species. The tree was reconstructed from a combined multi-locus sequence alignment (ITS, *gapdh*, *chs-1*, *his3*, *act* and *tub2*). For each locus the alignment was performed with MAFFT v7.450 (Katoh and Standley 2013), exported to MEGA7 (Kumar et al. 2016) and the best-fit substitution model

calculated. Phylogenetic analyses were performed with FastTree2 v2.1.10 (Price et al. 2010) and MrBayes 3.2.6 (Ronquist et al. 2012). Bayesian posterior probability (BPP) and Maximum-Likelihood (ML) bootstrap values (above 0.50) are reported next to the node. The scale bar represents the number of expected substitutions per site. GenBank accession numbers are listed in Supplementary file 1

rhombiforme and *C. salicis*) are from multiple locations (with *C. godetiae* presenting global distribution). Two relevant but singleton clades are the acutatum and fiorinia clades, comprising *C. acutatum* and *C. fiorinia* respectively. Whereas they are both of global distribution, *C. acutatum* appears to have originated from Oceania (or perhaps from the Indian Ocean basin) and *C. fiorinia* from the Northern Hemisphere.

Members of the acutatum species complex have been associated with 171 plant species belonging to 129 genera (Supplementary data 1) and the vast majority of those species (90.9%) belong are dicots whereas only a small proportion are monocots and gymnosperms (5.3% and 1.6% respectively). Interestingly the acutatum complex is known to comprise the only *Colletotrichum* entomopathogenic species as *C. fiorinia* is pathogenic towards *Fiorinia externa* (elongate hemlock scale; Marcelino et al. 2008) and *C. nymphaeae* is pathogenic on *Praelongorthezia praelonga* (citrus orthezia; Mascarin et al. 2016).

Whereas most of the species within the complex are polyphagous, some show a strong specialisation towards one or a limited group of hosts; e.g. *C. lupini* is highly specialised toward *Lupinus* spp. (Talhinhas et al. 2016). Species from the acutatum complex have been suggested as a model system for the study of fungal evolution on a fine scale because of their different host range and host preference, reproduction mode, and various living strategy (Baroncelli et al. 2017). Several species in the complex present limited geographical distribution or host range but some, such as *C. acutatum*, *C. fiorinia*, *C. godetiae* and *C. nymphaeae*, are of global distribution and multiple hosts. Whereas *C. godetiae* and *C. nymphaeae* have a plethora of other species in their phylogenetic vicinity, both *C. fiorinia* and *C. acutatum* are not accompanied by any other species in their tree branches. Given the vast amount of data for organisms in any of these four clades, it is unlikely that such differences are due to sampling bias and thus such differences could suggest diverse reproduction strategies that may have shaped different patterns of evolution (wide diversification in the nymphaeae and godetiae clades, as well as in the lupini one, and low diversity in the acutatum and fiorinia clades).

Colletotrichum abscissum Pinho and O.L. Pereira, *Persoonia* **34**: 237 (2015)

Colletotrichum abscissum is the causal agent of citrus Post-Bloom Fruit Drop (Crous et al. 2015). The fungus is restricted to *Citrus* spp. (Rutaceae) and to the American continent (Crous et al. 2015; Bragança et al. 2016; Silva et al. 2017a) and is thus a potential quarantine organism, namely in citrus producing areas.

Colletotrichum acerbum Damm, P.F. Cannon and Crous, *Stud. Mycol.* **73**: 43 (2012)

This species is based on a specimen collected from apple (*Malus domestica*, Rosaceae) in New Zealand in 1987 (Damm et al. 2012a). The fungus has not been detected thereafter, in spite of further research on apple bitter rot in New Zealand, as discussed by Damm et al. (2012a). This species could be endangered or even extinct from nature, particularly as other species of *Colletotrichum* inhabit the same ecosystem, causing apple bitter rot.

Colletotrichum acutatum J.H. Simmonds, *Qld. J. Agric. Anim. Sci.* **22**: 458 (1965)

Colletotrichum acutatum was originally described from Australia from diverse hosts and underwent several delimitations over time. Hosts harbouring *C. acutatum* sensu Damm et al. (2012a) include: in the Amaryllidaceae, *Allium cepa* (Lopes et al. 2021); in the Anacardiaceae, *Mangifera indica* and *Pistacia vera* (Shivas et al. 2016); in the Apocynaceae, *Nerium oleander* (Mosca et al. 2014); in the Caricaceae, *Carica papaya* (Damm et al. 2012a); in the Euphorbiaceae, *Hevea brasiliensis* (Hunupolagama et al. 2017); in the Fabaceae, *Aspalathus linearis* (Damm et al. 2012a) and *Vicia faba* (Shivas et al. 2016); in the Fagaceae, *Castanea sativa* (Gaffuri et al. 2017); in the Juglandaceae, *Juglans regia* (He et al. 2019); in the Myrtaceae, *Acca sellowiana* (Camele et al. 2018) and *Psidium guajava* (Liu et al. 2021b); in the Oleaceae, *Olea europaea* (Mosca et al. 2014; Chattaoui et al. 2016; Shivas et al. 2016; Iliadi et al. 2018; Talhinhas et al. 2018; Cara et al. 2021); in the Pinaceae, *Pinus radiata* (Damm et al. 2012a); in the Plumbaginaceae, *Limonium* sp. (Baroncelli et al. 2015); in the Proteaceae, *Grevillea* sp., *Hakea sericea* and *Leucadendron* sp. (Damm et al. 2012a); in the Punicaceae, *Punica granatum* (Mincuzzi et al. 2017); in the Ranunculaceae, *Anemone* sp. (Shivas et al. 2016); in the Rosaceae, *Fragaria* × *ananassa* (Damm et al. 2012a), *Malus domestica* (Shivas et al. 2016), *Prunus dulcis* (López-Moral et al. 2017) and *Pyrus pyrifolia* (Baroncelli et al. 2015); in the Rubiaceae, *Coffea arabica* (Damm et al. 2012a); in the Rutaceae, *Boronia megastigma* (Shivas et al. 2016), *Citrus limon* and *C. sinensis* (Guarnaccia et al. 2017); in the Solanaceae, *Solanum lycopersicum* (Liu et al. 2021b); in the Theaceae, *Camellia sinensis* (Chen et al. 2016a). Recorded mostly from Oceania and Africa in multiple hosts, *Colletotrichum acutatum* seems to be expanding to the Mediterranean region on several fruit crops, whereas it is virtually absent from the American continent (Supplementary data 2, panel A).

Colletotrichum arboricola M. Zapata, M.A. Palma and Piont., *Persoonia* **41**: 353 (2018)

Colletotrichum arboricola was recorded from *Fuchsia magellanica* (Onagraceae) leaves in 2012 in Chile (Crous et al. 2018a) but the authors note that the fungus was subsequently detected in different arboreal hosts in the area. Although pathogenicity has not been confirmed, this fungus may cause concern to this widely used ornamental host, although its distribution and host range are still poorly known.

Colletotrichum australe Damm, P.F. Cannon and Crous, *Stud. Mycol.* **73**: 57 (2012)

There are no further records for this species besides the two isolates, collected from *Trachycarpus fortunei* (Arecaceae) in Australia in 2011 and *Hakea* sp. (Proteaceae) in South Africa in 1998, originally used in the species description (Damm et al. 2012a). The current conservation status of this species requires further investigation.

Colletotrichum brisbanense Damm, P.F. Cannon and Crous, *Stud. Mycol.* **73**: 59 (2012)

There is a single isolate of *C. brisbanense*, collected from chilli (*Capsicum annuum*) in Australia in 1955 (Damm et al. 2012a). There are hundreds of reports of *Colletotrichum* on *Capsicum* spp. in the last decade, with over 30 different species of *Colletotrichum* associated, none of which corresponding to *C. brisbanense*, in spite of surveys conducted in Australia (Shivas et al. 2016). *Colletotrichum brisbanense* may well be extinct from nature.

Colletotrichum cairnsense D.D. De Silva, R. Shivas and P.W.J Taylor, *Plant Pathol.* **66**: 254 (2017)

There is a single isolate of *C. cairnsense*, collected from chilli (*Capsicum annuum*) in Australia in 2015 (De Silva et al. 2017a). The current conservation status of this species is unknown and of concern.

Colletotrichum carthami (Fukui) S. Uematsu, Kageyama, Moriwaki and Toy. Sato, *J. Gen. Plant Pathol.* **78**: 326 (2012)

Colletotrichum carthami is known from the Asteraceae *Calendula officinalis*, *Carthamus tinctorius* and *Glebionis coronaria* (= *Chrysanthemum coronarium*) from Italy, Japan and Korea (Damm et al. 2012a; Uematsu et al. 2012; Baroncelli et al. 2015; Sato et al. 2015). This fungus may be specific of Asteraceae.

Colletotrichum chrysanthemi (Hori) Sawada, *Rep. Govt. Res. Inst. Dep. Agric., Formosa* **85**: 81 (1943)

Colletotrichum chrysanthemi is a pathogen of Asteraceae (*Glebionis coronaria* and *Carthamus tinctorius*), recorded from Europe and China (Damm et al. 2012a; Baroncelli et al. 2015). Further research may shed light on the relative importance of the different species of *Colletotrichum* associated with these hosts.

Colletotrichum cosmi Damm, P.F. Cannon and Crous, *Stud. Mycol.* **73**: 61 (2012)

The species *Colletotrichum cosmi* was described based on an isolate collected from *Cosmos* sp. (Asteraceae) in the Netherlands prior to 1973 (Damm et al. 2012a). Although Damm et al. (2012a) discusses the possibility of the fungus being present on *Cosmos* spp. in India, Korea and Japan, no other fungi have been so far assigned to this species, rendering the conservation status of this species of great concern.

Colletotrichum costaricense Damm, P. F. Cannon and Crous, *Stud. Mycol.* **73**: 63 (2012)

The species *Colletotrichum costaricense* was described based on two isolates collected from berries and twigs of *Coffea* sp. (Rubiaceae) in Costa Rica prior to 1978 (Damm et al. 2012a). No other fungi have been assigned ever since to this species, rendering its conservation status of great concern, particularly as numerous species of *Colletotrichum* occur on coffee plants and despite numerous surveys conducted on this host.

Colletotrichum cuscutae Damm, P.F. Cannon and Crous, *Stud. Mycol.* **73**: 64 (2012)

The species *Colletotrichum cuscutae* was described based on a single isolate collected from *Cuscuta* sp. (Convolvulaceae) in Dominica in 1986 (Damm et al. 2012a). No other fungi have been assigned ever since to this species. *Colletotrichum* has been reported on *Cuscuta* from different parts of the world, but such isolates have not been characterised in modern terms. Only recently *C. fioriniae* was identified associated with *Cuscuta* sp. in the USA (Liu et al. 2021b). The conservation status of this species is thus of great concern.

Colletotrichum eriobotryae Damm and C.J. Huang, *Mycol. Prog.* **19**: 367 (2020)

Colletotrichum eriobotryae was recently recorded as a pathogen of loquat (*Eriobotrya japonica*, Rosaceae) in China (Taiwan) (Damm et al. 2020). Although *C. eriobotryae* showed to be the prevalent pathogen in that study, several species of *Colletotrichum* have been associated to loquat anthracnose, suggesting further studies to ascertain the geographic distribution, host range and pathological relevance of *C. eriobotryae*.

Colletotrichum fioriniae (Marcelino & Gouli) Pennycook, *Mycotaxon* **132**(1):150 (2017)

Colletotrichum fioriniae is a cosmopolitan fungus, found in all continents and in a wide range of host plants, but mostly occurring in temperate regions (Supplementary data 2, panel B). *Colletotrichum fioriniae* typically occurs along other *Colletotrichum* species associated to anthracnose symptoms, often being a less frequent and/or less virulent population. However, several reports consistently place *C. fioriniae* as the most frequently isolated fungus associated with apple bitter rot, namely in Europe and North America (Munda 2014; Munir et al. 2016; Nodet et al. 2016; Grammen et al. 2019). *Colletotrichum fioriniae* is known from: *Actinidia* sp. (Damm et al. 2012a) (Actinidiaceae); *Allium cepa* (Liu et al. 2021b) (Amaryllidaceae); *Mangifera indica* (Damm et al. 2012a), *Pistacia vera* (Lichtemberg et al. 2017) and *Toxicodendron radicans* (Kasson et al. 2014) (Anacardiaceae); *Annona cherimola* (Liu et al. 2021b) (Annonaceae); *Apium graveolens* (Liu et al. 2021b) (Apiaceae); *Ilex verticillata* (Lin et al. 2018a) and *I. integra* (Woo et al. 2021) (Aquifoliaceae); *Berberis* sp. (Damm et al. 2012a) and *B. aquifolium* (as *Mahonia aquifolium*) (Garibaldi et al. 2020; Guarnaccia et al. 2021) (Berberidaceae); *Corylus avellana* (Sezer et al. 2017) (Betulaceae); *Cuscuta* sp. (Liu et al. 2021b) (Convolvulaceae); *Cucurbita* sp. (Liu et al. 2021b) (Cucurbitaceae); *Kalmia* sp. (Damm et al. 2012a), *Rhododendron yedoense* (Sultana et al. 2018), *Vaccinium corymbosum* (Damm et al. 2012a; Eaton et al. 2021; Liu et al. 2021b), *V. macrocarpon* (Liu et al. 2021b) and *V. myrtilus* (Mosca et al. 2014) (Ericaceae); *Vernicia montana* (Zhang et al. 2021c) (Euphorbiaceae); *Acacia acuminata* (Shivas et al. 2016) (Fabaceae); *Fagus sylvatica* (Pszczółkowska et al. 2017) (Fagaceae); *Myriophyllum spicatum* (Damm et al. 2012a) (Haloragaceae); *Juglans regia* (Zhu et al. 2015; Varjas et al. 2019) (Juglandaceae); *Origanum vulgare* (Guarnaccia et al. 2019) and *Salvia leucantha* (Garibaldi et al. 2016c) (Lamiaceae); *Persea americana* (Damm et al. 2012a) (Lauraceae); *Tulipa* sp. (Damm et al. 2012a) (Liliaceae); *Liriodendron tulipifera*, *Magnolia* sp. (Damm et al. 2012a) and *M. champaca* (as *Michelia champaca*) (Zhang et al. 2018a) (Magnoliaceae);

Ficus virens (Xue et al. 2017) and *Morus alba* (Xue et al. 2019) (Moraceae); *Acca sellowiana* (Crous et al. 2019a) (Myrtaceae); *Olea europaea* (Damm et al. 2012a; Mosca et al. 2014; Talhinhos et al. 2018; Moreira et al. 2021) (Oleaceae); *Paeonia* sp. (Liu et al. 2021b) (Paeoniaceae); *Pinus radiata* (Baroncelli et al. 2015) (Pinaceae); *Piper nigrum* (Damm et al. 2012a) (Piperaceae); *Penstemon* sp. (Damm et al. 2012a) (Plantaginaceae); *Cyclamen* sp. and *Primula* sp. (Damm et al. 2012a) (Primulaceae); *Grevillea* sp. (Damm et al. 2012a) (Proteaceae); *Punica granatum* (Xavier et al. 2019) (Punicaceae); *Cydonia oblonga* (Liu et al. 2021b), *Fragaria* × *ananassa* (Damm et al. 2012a; Baroncelli et al. 2015), *Malus domestica* (Damm et al. 2012a; Kou et al. 2014; Munda 2014; Nodet et al. 2016; Oo et al. 2018; Grammen et al. 2019), *Prunus armeniaca* (Eaton et al. 2021), *P. dulcis* (Liu et al. 2021b), *P. persica* (Lee et al. 2018), *Pyrus communis* (Da Lio et al. 2017; Fu et al. 2019; Pavlović et al. 2019), *P. pyrifolia* (Damm et al. 2012a; Fu et al. 2019; Pavlović et al. 2019; Liu et al. 2021b) and *Rubus idaeus* (Schoeneberg and Hu 2020) (Rosaceae); *Coffea arabica* (Damm et al. 2012a) (Rubiaceae); *Acer negundo* (Liu et al. 2021b) and *Litchi chinensis* (Ling et al. 2021) (Sapindaceae); *Ailanthus altissima* (Hyde et al. 2017) (Simaroubaceae); *Capsicum annuum* (Diao et al. 2017), *Lycium barbarum* (Liu et al. 2016a), *L. chinense* (Oo et al. 2016), *Solanum lycopersicum* (Damm et al. 2012a; Chechi et al. 2019) and *S. melogena* (Xu et al. 2018a) (Solanaceae); *Camellia sinensis* (Wang et al. 2016) (Theaceae); *Parthenocissus* sp. (Damm et al. 2012a) (Vitaceae); *Fiorinia externa* (elongate hemlock scale insect) (Marcelino et al. 2008).

Colletotrichum godetiae Neerg., *Friesia* **4**: 72 (1950)

Colletotrichum godetiae is known from a large number of hosts and locations, with emphasis in Europe (Damm et al. 2012a; Jayawardena et al. 2016a) on almond, apple, peach, olive and strawberry (Supplementary data 2, panel C). It is known from: *Sambucus nigra* (Damm et al. 2012a) (Adoxaceae); *Schinus molle* (Damm et al. 2012a) (Anacardiaceae); *Berberis aquifolium* (as *Mahonia aquifolium*) (Damm et al. 2012a) (Berberidaceae); *Cornus mas* (Tóth et al. 2017) (Cornaceae); *Aeschynomene indica* (Damm et al. 2012a) (Fabaceae); *Juglans regia* (Damm et al. 2012a; Varjas et al. 2021) (Juglandaceae); *Laurus nobilis* (Damm et al. 2012a) and *Persea americana* (Hernández-Lauzardo et al. 2015) (Lauraceae); *Olea europaea* (Damm et al. 2012a; Mosca et al. 2014; Talhinhos et al. 2018) (Oleaceae); *Clarkia hybrida* (Damm et al. 2012a) (Onagraceae); *Ugni molinae* (Damm et al. 2012a) (Myrtaceae); *Podocarpus* sp. (Damm et al. 2012a) (Podocarpaceae); *Helleborus* sp. (Shivas et al. 2016) (Ranunculaceae); *Ceanothus* sp. (Damm et al. 2012a) (Rhamnaceae); *Citrus aurantium* (Damm et al. 2012a; Guarnaccia et al. 2017) (Rutaceae); *Agrimonia eupatoria*

(Damm et al. 2012a), *Cydonia oblonga* (Živković et al. 2014), *Eriobotrya japonica* (Juárez-Vázquez et al. 2019), *Fragaria × ananassa* (Damm et al. 2012a; Grammen et al. 2019), *Malus domestica* (Baroncelli et al. 2014; Shivas et al. 2016; Wenneker et al. 2016; Grammen et al. 2019), *Prunus avium* (Damm et al. 2012a; Grammen et al. 2019), *P. cerasus* (Damm et al. 2012a), *P. dulcis* (Damm et al. 2012a; López-Moral et al. 2017; Liu et al. 2021b), *Rubus glaucus* (Afanador-Kafuri et al. 2014) and *R. idaeus* (Damm et al. 2012a) (Rosaceae); *Solanum betaceum* (Damm et al. 2012a) (Solanaceae); *Parthenocissus* sp. (Damm et al. 2012a) and *Vitis vinifera* (Damm et al. 2012a; Zapparata et al. 2017) (Vitaceae).

Colletotrichum guajavae Damm, P.F. Cannon and Crous, *Stud. Mycol.* **73**: 69 (2012)

Colletotrichum guajavae was designated based on an isolate collected from *Psidium guajava* (Myrtaceae) in India at an unknown date (Damm et al. 2012a). The species was subsequently identified as one of the causal agents of anthracnose on leaves of small cardamom (*Elettaria cardamomum*, Zingiberaceae) in India in 2011 (Chethana et al. 2016). The pathological status of *C. guajavae* and its geographical distribution requires further investigation. As causal agent of small cardamom anthracnose, the pathogen may be of quarantine relevance.

Colletotrichum indonesiense Damm, P.F. Cannon and Crous, *Stud. Mycol.* **73**: 71 (2012)

There is a single record of *Colletotrichum indonesiense*, obtained from leaf spots developing after herbicide treatment of an undesigned species of *Eucalyptus* (Myrtaceae) in Indonesia in 2008 (Damm et al. 2012a). Although *Colletotrichum* records on eucalypts are seldom, the circumstances of the discovery of *C. indonesiense* and the lack of additional records for this taxon raise serious concerns on its conservation status.

Colletotrichum javanense D.D. De Silva, P.W. Crous and P.W.J. Taylor, *IMA Fungus* **10**: 8 (2019)

Colletotrichum javanense is based on a single isolate, obtained from a chilli (*Capsicum annum*, Solanaceae) fruit in Indonesia in 2014 (De Silva et al. 2019). The high number of species of *Colletotrichum* occurring on *Capsicum* raises serious concerns on the conservation status of *C. javanense*, prompting for further surveys to ascertain its distribution and prevalence. As this fungus was shown to be highly virulent to chilli (De Silva et al. 2019), it may turn out to become a fungus of quarantine relevance.

Colletotrichum johnstonii Damm, P.F. Cannon and Crous, *Stud. Mycol.* **73**: 72 (2012)

Colletotrichum johnstonii was described based on two isolates collected in New Zealand, from fruit rot in *Citrus* sp. and tomato (*Solanum lycopersicum*) in 1989 and 1990, respectively (Damm et al. 2012a). Recently Liu et al. (2021b) associated an additional fungus to this species, isolated from groundnut (*Arachis hypogaea*, Fabaceae), at an unknown location and date. No further occurrences of *C. johnstonii* have been reported which, along the large number of species of *Colletotrichum* known from each host, raises serious concern on the conservation status of this taxon.

Colletotrichum kinghornii Damm, P.F. Cannon and Crous, *Stud. Mycol.* **73**: 73 (2012)

Colletotrichum kinghornii, described based on a single isolate collected from *Phormium tenax* (Xanthorrhoeaceae) in the UK in 1935 (Damm et al. 2012a), has been recently identified on *Ph. cookianum* in New Zealand (Crous et al. 2021). The scarcity of records suggests that the fungus is rare, although the employment of the host plant as an ornamental raises caution of possible quarantine implications.

Colletotrichum kniphofiae Crous and Denman, *Fungal Syst. Evol.* **1**: 180 (2018)

Colletotrichum kniphofiae was recently described based on an isolate collected from *Kniphofia uvaria* (Xanthorrhoeaceae) dead leaves in the UK in 2016 (Crous et al. 2018b). Nothing is known about its ecology or pathology and no other species of *Colletotrichum* have been reported from *K. uvaria*, although *C. spaethianum* has been reported from *K. northiae* (Sato et al. 2015). The conservation status of *C. kniphofiae* is therefore of great uncertainty.

Colletotrichum laticiphilum Damm, P.F. Cannon and Crous, *Stud. Mycol.* **73**: 74 (2012)

The species *Colletotrichum laticiphilum* was described to accommodate fungi isolated from anthracnose symptoms on rubber tree (*Hevea brasiliensis*, Euphorbiaceae) leaves in Colombia and India (Damm et al. 2012a). The fungus was subsequently identified in Sri Lanka in 2012 also associated to anthracnose of rubber tree (Hunupolagama et al. 2017), suggesting that this fungus may be host specific. Several species of *Colletotrichum* occur on rubber tree, prompting further studies to analyse the pathological relevance and conservation status of *C. laticiphilum*.

Colletotrichum lauri Jayawardena, Camporesi and K.D. Hyde, *Fungal Divers.* **87**: 148 (2017)

The species *Colletotrichum lauri* was described to accommodate an isolate obtained from dead leaves of laurel (*Laurus nobilis*, Lauraceae) collected in Italy in 2015 (Hyde et al. 2017). There are no other reports of this fungus worldwide and there are other species of *Colletotrichum* reported from laurel, raising serious concern about the conservation status of *C. lauri*.

Colletotrichum limetticola (R.E. Clausen) Damm, P.F. Cannon and Crous, *Stud. Mycol.* **73**: 76 (2012)

The species *Colletotrichum limetticola* is based on fungi isolated from wither tip symptoms on sour lime (*Citrus aurantiifolia*, Rutaceae) in Cuba and the USA (Damm et al. 2012a), but such records are dated from the 1910s, and no further occurrences have been recorded ever since on citrus, although several species of *Colletotrichum* are known from these hosts. However, *C. limetticola* was recently found in Brazil causing Glomerella leaf spot on apples, showing low prevalence but high virulence (Moreira et al. 2019a). Both hosts are subject of numerous studies concerning the identification of *Colletotrichum*, hence the scarcity of records of *C. limetticola* raise concern on its conservation status.

Colletotrichum lupini (Bondar) Damm, P.F. Cannon and Crous, *Stud. Mycol.* **73**: 78 (2012)

Colletotrichum lupini is the lupin anthracnose pathogen, reported from different parts of the world (Supplementary data 2, panel D) on several species of *Lupinus* (Fabaceae), including *L. albus*, *L. angustifolius*, *L. consentinii*, *L. hartwegii*, *L. luteus*, *L. mutabilis* and *L. polyphyllus* (Talhinhos et al. 2016). It is thus a host-specific pathogen of global distribution and common occurrence, although it has been sporadically reported from other hosts.

Colletotrichum melonis Damm, P.F. Cannon and Crous, *Stud. Mycol.* **73**: 80 (2012)

The taxon *Colletotrichum melonis* was described to accommodate a fungus isolated from melon (*Cucumis melo*, Cucurbitaceae) in Brazil prior to 1984 (Damm et al. 2012a). Although there are no further reports of *Colletotrichum melonis* from melon, the fungus was subsequently reported from persimmon (*Diospyros kaki*, Ebenaceae) in Brazil (Carraro et al. 2019) and from apple (*Malus domestica*, Rosaceae) in Brazil and Uruguay (Alaniz et al. 2015; Bragança et al. 2016; Moreira et al. 2019a). *Colletotrichum melonis* seems to be common in Southeastern South America.

Colletotrichum miaoliense P.C. Chung & H.Y. Wu, in Chung, Wu, Wang, Hu, Ariyawansa, Hung, Tzean & Chung, *Sci. Rep.* **10**(no. 14664): 6 (2020)

Colletotrichum miaoliense is known only from Taiwan, associated to strawberry anthracnose among several pathogens from other species of *Colletotrichum* (Chung et al. 2020). The conservation status of this fungus remains to be analysed.

Colletotrichum nymphaeae (Pass.) Aa, *Neth. J. Plant Pathol.*, **84**: 110 (1978)

Damm et al. (2012a) recognised *Colletotrichum nymphaeae* as a pathogen of *Anemone* sp. (Ranunculaceae), *Capsicum* sp. (Solanaceae), *Fragaria* × *ananassa*, *Malus pumila* and *Photinia* sp. (Rosaceae), *Leucaena* sp. and *Phaseolus* sp. (Fabaceae), *Berberis aquifolium* (= *Mahonia aquifolium*, Berberidaceae), *Nuphar lutea* and *Nymphaea alba* (Nymphaeaceae), *Oenothera* sp. (Onagraceae), *Olea europaea* (Oleaceae), *Pelargonium graveolens* (Geraniaceae) and *Protea* spp. (Proteaceae). The fungus was subsequently identified from: *Actinidia arguta* (Actinidiaceae) in Korea (Kim et al. 2018); *Allium cepa* (Amaryllidaceae) in Brazil (Lopes et al. 2021); *Apium graveolens* (Apiaceae) in Japan (Yamagishi et al. 2015); *Camellia oleifera* (Theaceae) in China (Li and Li 2020); *Campanula rapunculoides* (Campanulaceae) in Italy (Guarnaccia et al. 2021); *Carya illinoensis* (Juglandaceae) in Brazil and China (Poletto et al. 2019; Zhang et al. 2019a); *Citrus aurantiifolia* (as *Colletotrichum citri*; Damm et al. 2020) and *Citrus limon* (Rutaceae) in China and Australia respectively (Huang et al. 2013; Shivas et al. 2016); *Cyclamen persicum* (Primulaceae) in Italy (Mosca et al. 2014); *Diospyros kaki* (Ebenaceae) in Brazil and Korea (Carraro et al. 2019; Hassan et al. 2019a); *Eriobotrya japonica* (Rosaceae) in China (Wu et al. 2018); *Hevea brasiliensis* (Euphorbiaceae) in Sri Lanka (Hunupolagama et al. 2017); *Ilex verticillata* × *I. serrata* (Aquifoliaceae) in the USA (Lin et al. 2018a); *Juglans regia* (Juglandaceae) in Brazil (Savian et al. 2019); *Malus domestica* (Rosaceae) in Brazil, Korea and the USA (Velho et al. 2014b; Munir et al. 2016; Oo et al. 2018); *Prunus persica* and *P. salicina* (Rosaceae) in Brazil and Korea respectively (Chang et al. 2018a; Moreira et al. 2020); *Psidium guajava* (Myrtaceae) in Brazil (Bragança et al. 2016); *Punica granatum* (Lythraceae) in the USA (Xavier et al. 2019); *Pyrus pyrifolia* (Rosaceae) in Brazil (Moreira et al. 2019b); *Robinia pseudoacacia* (Fabaceae) in Japan (Yamagishi et al. 2016); *Rubus corchorifolius* (Rosaceae) in China (Wu et al. 2021); *Solanum lycopersicum* (Solanaceae) in the USA (Chechi et al. 2019); *Vitis vinifera* (Vitaceae) in China (Liu et al. 2016b); the citrus scale insect *Praelongorthezia praelonga* (Hemiptera:

Ortheziidae) in Brazil as *Colletotrichum nymphaeae* var. *entomophilum* (Wynns et al. 2019). Thus, *C. nymphaeae* occurs on a vast list of important agricultural crops, often as the main causal agent of anthracnose (such as strawberry anthracnose). Whereas older reports were more frequent in the Old World, most reports from the 2010s decade are from America, suggesting a recent spread over this continent (Supplementary data 2, panel E).

Colletotrichum paranaense C.A.D. Bragança and Damm, *Fungal Biol.* **120**: 555 (2016)

Colletotrichum paranaense is known from Brazil only, associated to anthracnose symptoms in apple (*Malus domestica*) and peach (*Prunus persica*) fruits, as well as from *Caryocar brasiliense* (Caryocaraceae) (Bragança et al. 2016). In a population study, *C. paranaense* was identified in several states in Brazil associated to apple Glomerella leaf spot disease, although not as the most frequent pathogen (Moreira et al. 2019a). Further surveys will clarify the geographical distribution of *Colletotrichum paranaense*, its pathological relevance to apple and other crops, as well as its conservation status.

Colletotrichum paxtonii Damm, P.F. Cannon and Crous, *Stud. Mycol.* **73**: 85 (2012)

The species *Colletotrichum paxtonii* is known only from a fungus obtained from *Musa nana* (Musaceae) in Saint Lucia in 1972 (Damm et al. 2012a). The inexistence of any further occurrences of this species, in spite of the widespread cultivation of banana, along with the frequent occurrence of other species of *Colletotrichum* in this host, suggests that *C. paxtonii* may be extinct from nature.

Colletotrichum phormii (Henn.) D.F. Farr and Rossmann, *Mycol. Res.* **110**: 1403 (2006)

Colletotrichum phormii occurs on New Zealand flax (*Phormium tenax* and *Ph. colensoi*, Xanthorrhoeaceae), being reported from Australia, New Zealand, South Africa, Germany, the Netherlands, UK and the USA (Supplementary data 2, panel F), with reports spanning from the late nineteenth century till contemporary times (Damm et al. 2012a; Serdani et al. 2013; Baroncelli et al. 2015; Shivas et al. 2016). *Colletotrichum phormii* seems to be the most common causal agent of New Zealand flax anthracnose and it appears to be a relatively common fungus on this host.

Colletotrichum pyricola Damm, P.F. Cannon and Crous, *Stud. Mycol.* **73**: 94 (2012)

Defined originally based on an isolate collected from a pear (*Pyrus communis*, Rosaceae) fruit rot in New Zealand in 1988 (Damm et al. 2012a), *Colletotrichum pyricola* was

subsequently identified associated to leaf and tip dieback of *Daphne odora* (Thymelaeaceae) in Australia (although collected in 1983) (Shivas et al. 2016) and to leaf spots of *Embothrium coccineum* (Proteaceae) in Chile in 2015 (Zapata and Opazo 2017). Although reported from diverse hosts and locations, this fungus is rarely recorded, prompting further studies to better ascertain its conservation status.

Colletotrichum rhombiforme Damm, P.F. Cannon and Crous, *Stud. Mycol.* **73**: 95 (2012)

Colletotrichum rhombiforme was described based on two isolates, obtained from olive (*Olea europaea*, Oleaceae) in Portugal in 2003 (Talhinhas et al. 2005; Damm et al. 2012a) and from blueberry (*Vaccinium macrocarpum*, Ericaceae) in the USA (Damm et al. 2012a). The species was subsequently identified from apple (*Malus domestica*, Rosaceae) in Belgium in 2014 (Grammen et al. 2019) and in China in 2016 (Wu et al. 2017) and from *Vaccinium dunalianum* var. *urophyllum* in China (Wang et al. 2019b). Whereas this species seems widespread, the scarcity of its records spread through several hosts suggests that further surveys are needed to ascertain its distribution, pathological relevance and conservation status.

Colletotrichum roseum M. Zapata, M.A. Palma, M.J. Aninat and Piont., *Persoonia* **43**: 354 (2019)

The species *Colletotrichum roseum* contains isolates obtained from *Lapageria rosea* (Philesiaceae) in Chile in 2018 (Crous et al. 2019a). The geographical distribution, pathological relevance and conservation status of *Colletotrichum roseum* remains to be clarified.

Colletotrichum salicis (Fuckel) Damm, P.F. Cannon and Crous, *Stud. Mycol.* **73**: 97 (2012)

The species *Colletotrichum salicis* contains fungi occurring on diverse hosts and regions, in higher latitudes than most other species of *Colletotrichum* (Supplementary data 2, panel G): *Acer platanoides* (Sapindaceae) in the USA (Damm et al. 2012a); *Araucaria columnaris* (as *Araucaria excelsa*, Araucariaceae) in the USA (Damm et al. 2012a); *Fragaria × ananassa* (Rosaceae) in Belgium and New Zealand (Damm et al. 2012a; Grammen et al. 2019); *Malus domestica* (Rosaceae) in Belgium, Germany and New Zealand (Damm et al. 2012a; Grammen et al. 2019); *Populus × canadensis* and *P. nigra* (Salicaceae) in the Netherlands and Iran respectively (Damm et al. 2012a; Khodaei et al. 2019); *Pyrus pyrifolia* (Rosaceae) in New Zealand (Damm et al. 2012a); *Rhododendron* sp. (Ericaceae) in Latvia (Damm et al. 2012a); *Salix* spp. (Salicaceae) in Australia, New Zealand, Japan, Poland, Germany, the Netherlands and UK (Damm et al. 2012a; Shivas et al. 2016; Okorski et al. 2018); *Solanum*

lycopersicum (Solanaceae) in Germany (Damm et al. 2012a); *Vaccinium corymbosum* (Ericaceae) in Norway (Damm et al. 2012a). Although there are some recent reports of *Colletotrichum salicis*, most occurrences are old, suggesting that this fungus may not be very common in present days.

Colletotrichum scovillei Damm, P.F. Cannon and Crous, *Stud. Mycol.* **73**: 100 (2012)

Colletotrichum scovillei is a species associated to chilli (*Capsicum* spp., Solanaceae) anthracnose. This species is known from Asia (China, Indonesia, Japan, Korea and Thailand; Damm et al. 2012a; Kanto et al. 2014; Zhao et al. 2016a; Oo et al. 2017; Huo et al. 2021), but also from Brazil (Caires et al. 2014) and the USA (Toporek and Keinath 2021) (Supplementary data 2, panel H). Recently it has been reported in China associated to anthracnose symptoms on banana (*Musa acuminata*, Musaceae) (Zhou et al. 2017), mango (*Mangifera indica*, Anacardiaceae) (Qin et al. 2019) and wampi (*Clausena lansium*, Rutaceae) (Lin et al. 2020), and from Brazil associated to anthracnose symptoms on onion (Lopes et al. 2021). The host range of *C. scovillei* and the pathological relevance for crops other than chillies still need to be fully elucidated.

Colletotrichum simmondsii R.G. Shivas and Y.P. Tan, *Fungal Divers.* **39**: 119 (2009)

Colletotrichum simmondsii sensu Damm et al. (2012a) is a fungus recorded predominantly from Australia, on multiple hosts: *Actinidia chinensis* (Actinidiaceae); *Averrhoa carambola* (Oxalidaceae); *Calothamnus quadrifidus* (Myrtaceae); *Capsicum annuum* (Solanaceae); *Carica papaya* (Caricaceae); *Citrus reticulata* (Rutaceae); *Cyclamen* sp. (Primulaceae); *Fragaria* × *ananassa* (Rosaceae); *Hevea brasiliensis* (Euphorbiaceae); *Litchi chinensis* (Sapindaceae); *Mandevilla* sp. (Apocynaceae); *Mangifera indica* (Anacardiaceae); *Murraya* sp. (Rutaceae); *Nepheium lappaceum* (Sapindaceae); *Protea cynaroides* (Proteaceae); *Prunus domestica* (Rosaceae); *Punica granatum* (Punicaceae); *Solanum betaceum* and *S. lycopersicum* (Solanaceae); *Vaccinium corymbosum* (Ericaceae) (Damm et al. 2012a; Shivas et al. 2016; Guarnaccia et al. 2017; Hunupolagama et al. 2017; De Silva et al. 2017a; Xavier et al. 2019). Few occurrences of *Colletotrichum simmondsii* are recorded from countries other than Australia and even fewer are recent, whereas most of the recent reports of the fungus are from Australia, suggesting this species to be mostly geographically confined to this country (Supplementary data 2, panel I).

Colletotrichum sloanei Damm, P.F. Cannon and Crous, *Stud. Mycol.* **73**: 103 (2012)

Colletotrichum sloanei was described based on a fungus isolated from cacao (*Theobroma cacao*, Malvaceae) in Malaysia in 1994 (Damm et al. 2012a). It was subsequently isolated from lychee

(*Litchi chinensis*, Sapindaceae) in Australia in 2003 (Shivas et al. 2016) and recently from apple (*Malus domestica*, Rosaceae) and guava (*Psidium guajava*, Myrtaceae) in Indonesia in 2019 (Zhafarina et al. 2021). Records of *C. sloanei* are scarce and dispersed which, along with the occurrence of several other species of *Colletotrichum* on its hosts, render its conservation status of concern.

Colletotrichum tamarilloi Damm, P.F. Cannon and Crous, *Stud. Mycol.* **73**: 105 (2012)

Colletotrichum tamarilloi is the causal agent of anthracnose on tamarillo (*Solanum betaceum*, Solanaceae), reported from Colombia and Ecuador (Damm et al. 2012a; Pardo-De la Hoz et al. 2016; Caicedo et al. 2017), although Pardo-De la Hoz et al. (2016) also reported this fungus from mango in Colombia, and recently Lopes et al. (2021) reported it from onion in Brazil (Supplementary data 2, panel J). *Colletotrichum tamarilloi* thus seems to be mostly a host specific fungus of common occurrence on its host, but disseminating in South America.

Colletotrichum walleri Damm, P.F. Cannon and Crous, *Stud. Mycol.* **73**: 106 (2012)

Colletotrichum walleri is only known from a single isolate, obtained from coffee (*Coffea arabica*) in Vietnam in an unknown date (Damm et al. 2012a). Several species of *Colletotrichum* are known from coffee and there are no further records attributable to *C. walleri*, raising serious concerns about the actual existence of this species in nature.

Colletotrichum wanningense X.R. Cao, H.Y. Che and D.Q. Luo, *Plant Dis.* **103**: 117 (2019)

Colletotrichum wanningense was designated based on a single isolate obtained from an asymptomatic leaf of rubber tree (*Hevea brasiliensis*, Euphorbiaceae) in China in 2017 (Cao et al. 2019b). Considering the large number of species of *Colletotrichum* recorded from *Hevea* and the absence of any further records of *Colletotrichum wanningense*, concerns arise on the actual conservation status of this species, prompting further surveys to ascertain its presence in nature.

The Agaves species complex

Recently described (Bhunjun et al. 2021), the agaves species complex is a well-established monophyletic group of five species, *Colletotrichum agaves*, *C. ledebouriae*, *C. neosansevieriae*, *C. euphorbiae* and *C. sansevieriae* (Fig. 4), considered until recently as singletons (Jayawardena et al. 2016a; Marín-Felíx et al. 2017). The species complex name comes from *C. agaves* that has been the first species of this group described (Farr et al. 2006). Among the species encompassed in this complex, three

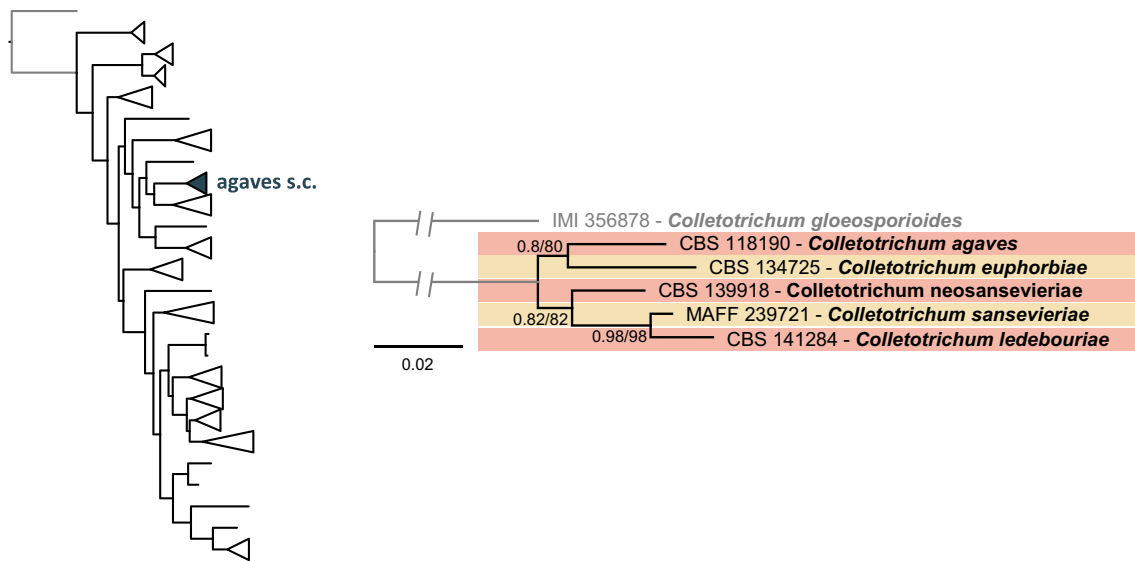

Fig. 4 Bayesian inference phylogenetic tree of the agaves species complex. The tree was reconstructed from a combined multi-locus sequence alignment (ITS, *gapdh*, *his3*, *act* and *tub2*). For each locus the alignment was performed with MAFFT v7.450 (Kato and Standley 2013), exported to MEGA7 (Kumar et al. 2016) and the best-fit substitution model calculated. Phylogenetic analyses were performed

with FastTree2 v2.1.10 (Price et al. 2010) and MrBayes 3.2.6 (Ronquist et al. 2012). Bayesian posterior probability (BPP) and Maximum-Likelihood (ML) bootstrap values (above 0.50) are reported next to the node. The scale bar represents the number of expected substitutions per site. GenBank accession numbers are listed in Supplementary file 1

species (*C. ledebouriae*, *C. neosanseveriae* and *C. euphorbiae*) seem to be extremely rare as they have been reported only once in South Africa. *Colletotrichum agaves* has been reported in several geographic regions (Italy, Mexico, USA, Cuba, Jamaica, Haiti, El Salvador) but not in the past 15 years, while several records have reported *C. sanseveriae* in diverse regions of Asia and in the USA. Interestingly four of the species encompassed in this complex such as *C. agaves*, *C. ledebouriae*, *C. neosanseveriae* and *C. sanseveriae* have been reported only on hosts belonging to the Asparagaceae family (Liliopsida [monocot]; Asparagales) whereas only one testimony of *C. euphorbiae* on *Euphorbia* sp. (Magnoliopsida [eudicot], Euphorbiales, Euphorbiaceae) has been reported.

Colletotrichum agaves Cavara, *Fung. Long. Exsicc.* 3: no. 100 (1892)

As reviewed by Farr et al. (2006), most reports of *Colletotrichum agaves* are from the first half of the twentieth century. The three most recent records are from 2002 in Mexico, from 1982 in the USA and from 1979 in the Netherlands on *Agave* spp. (Supplementary data 3, panel A). Other *Colletotrichum* spp. occur on the Agavaceae and the current conservation status of *C. agaves* is of concern.

Colletotrichum euphorbiae Damm and Crous, *Persoonia* 31: 203 (2013)

The only record of *Colletotrichum euphorbiae* is from leaves of an unspecified species of *Euphorbia* collected at the Kirstenbosch Botanical Garden in South Africa in 2012 (Crous et al. 2013). There is no information on the pathological status of this fungus neither on whether the host plant was present as part of the botanical collection or as a weed. Considering that *Euphorbia* is a vast genus and one of the most morphologically diverse in botany, the conservation status of *C. euphorbiae* can be considered of extreme concern.

Colletotrichum ledebouriae Crous and M.J. Wingf., *Persoonia* 36: 331 (2016)

There is a single record of *Colletotrichum ledebouriae*, obtained from *Ledebouria floribunda* (Asparagaceae) in 2014 in South Africa (Crous et al. 2016). There are no records of anthracnose on this host and no further records for *C. ledebouriae*, raising serious concerns about its conservation status.

Colletotrichum neosansevieriae Crous and N.A. van der Merwe, *Persoonia* **34**: 221 (2015)

This species is known only from a single isolate, collected in South Africa from *Sansevieria trifasciata* (Asparagaceae) in 2014 (Crous et al. 2015). The absence of further records for this fungus and the occurrence of other species of *Colletotrichum* on *Sansevieria* raises serious concerns on the conservation status of *C. neosansevieriae*.

Colletotrichum sansevieriae Miho Nakam. and Ohzono, *J. Gen. Plant Pathol.* **72**: 253 (2006)

Colletotrichum sansevieriae is reported from *Sansevieria trifasciata* (Asparagaceae) in Japan since 1997 (Nakamura et al. 2006), in Australia since 2008 (Aldaoud et al. 2011), in the USA since 2010 (Palmateer et al. 2012), in Korea since 2012 (Park et al. 2013), in Iran since 2015 (Karimi et al. 2017) and in Malaysia since 2015 (Kee et al. 2020) (Supplementary data 3, panel B). *Colletotrichum sansevieriae* seems to be common and to show a high host specificity.

The boninense species complex

As a species, *Colletotrichum boninense* was first described in 2003 associated with *Crinum asiaticum* (Amaryllidaceae) in

Japan (Moriwaki et al. 2003). Historically *C. boninense* was described as a pathogen and endophyte of a wide range of plant hosts worldwide until 2012 when Damm and colleagues (Damm et al. 2012b) used an MLST approach on 86 strains previously identified as *C. boninense* and other related strains revealing 18 clades and describing 17 of those as novel species. Since the taxonomic revision and the description of what is now known as the boninense species complex, more species have been described. Currently boninense is the third largest complex of the genus encompassing 26 described species (Fig. 5). Among these, half have only been reported once, whereas others such as *C. boninense* and *C. cymbidiicola* have been reported several times. Inside this complex *C. karsti* is by far the most cosmopolitan and polyphagous species as it has been associated with more than 60 plant species worldwide. Like the acutatum and the gloeosporioides species complexes, the boninense complex includes highly polyphagous species as well as species that show a certain level of specialisation. For example, *C. cymbidiicola* has been reported on at least eight plant hosts belonging to different genera but all of them belonging to the Orchidaceae family (Liliopsida [monocot]; Orchidales). A geographic and host-range analysis of the phylogeny of the boninense species complex reveal that: fungi in the clade containing *C. annellatum*, *C. camelliae-japonicae*, *C. citricola*, *C. chongqingense*, *C. karsti* and *C. phyllanthi* occur mostly in Asia and Oceania (but *C. karsti* is of global distribution); those in the clade containing *C.*

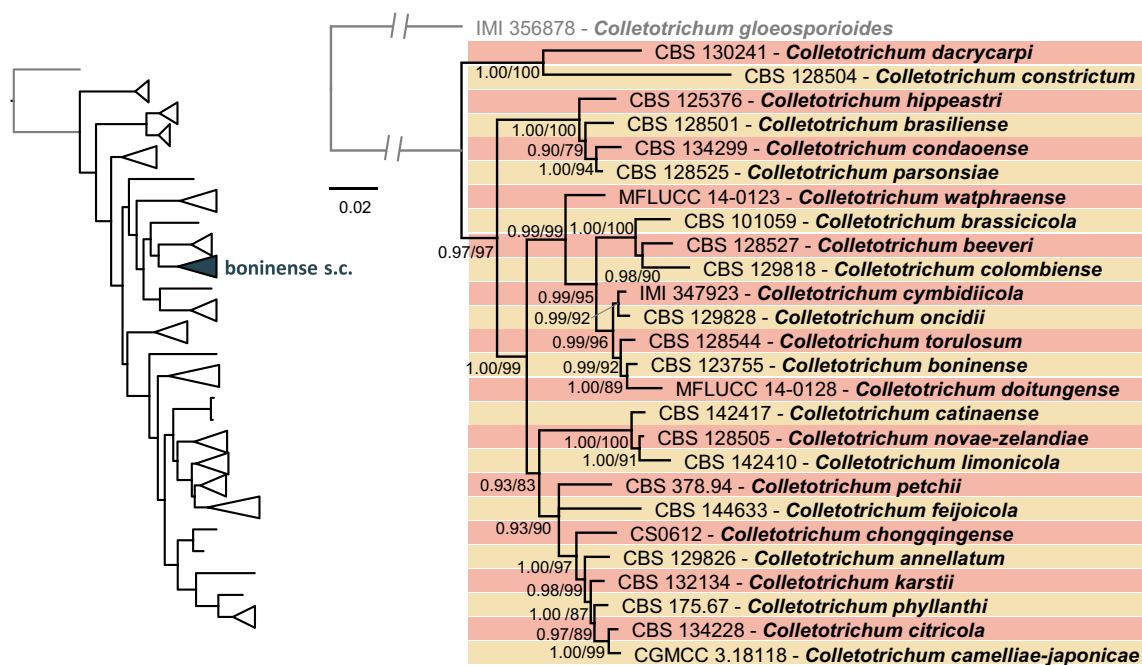

Fig. 5 Bayesian inference phylogenetic tree of the boninense species complex. The tree was reconstructed from a combined multi-locus sequence alignment (ITS, *gapdh*, *chs-1*, *his3*, *act*, *cal* and *tub2*). For each locus the alignment was performed with MAFFT v7.450 (Kato and Standley 2013), exported to MEGA7 (Kumar et al. 2016) and the best-fit substitution model calculated. Phylogenetic analyses were

performed with FastTree2 v2.1.10 (Price et al. 2010) and MrBayes 3.2.6 (Ronquist et al. 2012). Bayesian posterior probability (BPP) and Maximum-Likelihood (ML) bootstrap values (above 0.50) are reported next to the node. The scale bar represents the number of expected substitutions per site. GenBank accession numbers are listed in Supplementary file 1

catinaense, *C. limonicola* and *C. novae-zelandiae* are associated with citrus in Mediterranean Europe and New Zealand; fungi in the clade containing *C. beeveri*, *C. boninense*, *C. brassicicola*, *C. colombiense*, *C. cymbidiicola*, *C. doitungense*, *C. oncidii* and *C. torulosum* occur mostly in Asia and Oceania, with the *C. cymbidiicola*—*C. oncidii* cluster specifically from orchids; the fungi in the clade containing *C. brasiliense*, *C. condaoense*, *C. hippeastri* and *C. parsonsi* originate from multiple continents; the clade comprising *C. constrictum* and *C. dacrycarpi*, phylogenetically basal to the complex, contains fungi from New Zealand. This phylogeographic approach indicates a wider species diversity in Asia and Oceania, suggesting that the complex may have originated from there.

Colletotrichum annellatum Damm, P.F. Cannon and Crous, *Stud. Mycol.* **73**: 6 (2012)

There is a single record for *Colletotrichum annellatum*, collected from *Hevea brasiliensis* leaves in Colombia in 2010, with unconfirmed pathogenicity (Damm et al. 2012b). The pathological relevance and ecological status of this species remains to be analysed.

Colletotrichum beeveri Damm, P.F. Cannon, Crous, P.R. Johnst and B. Weir, *Stud. Mycol.* **73**: 9 (2012)

There is a single record for *Colletotrichum beeveri*, from *Brachyglottis repanda* (Asteraceae) in New Zealand in 2006, although sequence similarity suggests its occurrence as endophyte on *Pleione bulbocodioides* (Orchidaceae) in China and on Podocarpaceae in New Zealand (Damm et al. 2012b). The current conservation status of this species is therefore of concern.

Colletotrichum boninense Moriwaki, Toy. Sato and Tsukib., *Mycoscience* **44**: 48 (2003)

Colletotrichum boninense is recorded from several hosts, often as endophyte, mostly in Asia and Oceania (Damm et al. 2012b) (Supplementary data 4, panel A), including *Crinum asiaticum* var. *sinicum* (Amaryllidaceae; Damm et al. 2012b), *Tecomanthe speciosa* (Bignoniaceae; Damm et al. 2012b), *Vriesea imperialis* (as *Alcantarea imperialis*) (Bromeliaceae; Meneses et al. 2019), *Manihot esculenta* (Euphorbiaceae; Hyde et al. 2018), *Eucalyptus robusta* (Myrtaceae; Zhang and Zhu 2018), *Bletilla ochracea* and *Dendrobium* sp. (Orchidaceae; Tao et al. 2013; Hyde et al. 2018), *Dacrycarpus dacrydioides* (Podocarpaceae; Damm et al. 2012b), *Leucospermum* sp. (Proteaceae; Damm et al. 2012b), *Coptis chinensis* (Ranunculaceae; Ding et al. 2020); *Capsicum frutescens*, *Solanum betaceum* and *S. lycopersicum* (Solanaceae; Damm et al. 2012b; Diao et al. 2013;

Rashid et al. 2015), *Fragaria × ananassa*, *Rosa chinensis* and *Rubus rosaefolius* (Rosaceae; Bi et al. 2017b; Ding et al. 2021; Zheng et al. 2021a), *Coffea arabica* (Rubiaceae; Freitas et al. 2013), *Citrus medica* (Rutaceae; Guarnaccia et al. 2017) and *Camellia sinensis* (Theaceae; Liu et al. 2015b).

Colletotrichum brasiliense Damm, P.F. Cannon, Crous and Massola, *Stud. Mycol.* **73**: 11 (2012)

A single isolate is known for *Colletotrichum brasiliense*, collected in Brazil in 2006 from *Passiflora edulis* fruits (Damm et al. 2012b). Additional species of *Colletotrichum* are known from passionfruit (Damm et al. 2012b), raising concern on the conservation status of *C. brasiliense*.

Colletotrichum brassicicola Damm, P.F. Cannon and Crous, *Stud. Mycol.* **73**: 14 (2012)

There are only two known isolates for this species, collected respectively in New Zealand on *Brassica oleracea* var. *gemmifera* in an unknown date prior to 1998 (Damm et al. 2012b) and in Colombia on *Rubus glaucus* in 2008 (Afanador-Kafuri et al. 2014). Both plant species host several other species of *Colletotrichum*, therefore the pathological relevance and conservation status of *C. brassicicola* remains to be clarified.

Colletotrichum camelliae-japonicae LW. Hou and L. Cai, *Mycosphere* **7**: 1117 (2016)

Colletotrichum camelliae-japonicae was reported only once, in 2013, on *Camellia japonica* plants from Japan (Hou et al. 2016). The conservation status of this pathogen is unknown and of concern.

Colletotrichum catinaense Guarnaccia and Crous, *Persoonia* **39**: 32 (2017)

This species is known from *Citrus sinensis* (fruit tear-stain) and *C. reticulata* (leaf lesion) collected in 2015 in Portugal and Italy (Guarnaccia et al. 2017). As several species of *Colletotrichum* are found on *Citrus* spp. (Huang et al. 2013; Ramos et al. 2016; Douanla-Meli and Unger 2017; Guarnaccia et al. 2017; Silva et al. 2017a; Uysal and Kurt 2019), the pathological relevance and conservation status of *Colletotrichum catinaense* need to be further investigated.

Colletotrichum chongqingense Y.J. Chen, *Plant Dis.* **105**: 1474 (2021) (in press)

The species *Colletotrichum chongqingense* was described based on a single isolate associated to anthracnose symptoms on *Camellia sinensis* (Theaceae) leaves in China, isolated in 2017 (Wan et al. 2021). Considering the vast number of species of *Colletotrichum* known from tea plants, the pathological relevance and conservation status of *C. chongqingense* are much uncertain.

Colletotrichum citricola F. Huang, L. Cai, K.D. Hyde and Hong Y. Li, *Fungal Divers.* **61**: 67 (2013)

Initially described as an endophyte of *Citrus unchiu* collected in 2012 in China (Huang et al. 2013), *Colletotrichum citricola* was subsequently isolated from anthracnose symptoms on leaves of *Pyrus pyrifolia* in 2015 in China (Fu et al. 2019) and from healthy *Dendrobium* sp. plants in Thailand (Ma et al. 2018). All three host plants harbor other species of *Colletotrichum*, rendering the pathologic relevance of *C. citricola* uncertain and its conservation status of concern.

Colletotrichum colombiense Damm, P.F. Cannon and Crous, *Stud. Mycol.* **73**: 16 (2012)

Colletotrichum colombiense is based on an isolate collected from *Passiflora edulis* in Colombia in 2010 (Damm et al. 2012b). Additional isolates obtained from *Passiflora* sp. in Colombia may also belong to *C. colombiense*, as discussed by Damm et al. (2012b). Nevertheless, given that there are several species of *Colletotrichum* occurring on *Passiflora*, the conservation status of *C. colombiense* is uncertain.

Colletotrichum condaoense Damm, *Persoonia* **40**: 240 (2018)

Colletotrichum condaoense is based on an isolate collected from *Ipomoea pes-caprae* (Convolvulaceae) in Vietnam in 2012 (Crous et al. 2018c). No other species of *Colletotrichum* have been reported on this host species. The host is widespread in tropical coastal areas, suggesting that the conservation status of *C. condaoense* should be investigated.

Colletotrichum constrictum Damm, P.F. Cannon, Crous, P.R. Johnst and B. Weir, *Stud. Mycol.* **73**: 17 (2012)

Colletotrichum constrictum is composed of two strains, collected in New Zealand in 1988 from diseased lemon (*Citrus limon*) and tamarillo (*Solanum betaceum*) fruits, and presumably also of strains collected from *Passiflora edulis* and *P. mollissima* also in New Zealand (Damm et al. 2012b). No

new strains have been assigned to *C. constrictum* for over 30 years which, together with the fact that all hosts harbor several species of *Colletotrichum*, render the conservation status of the species of great concern.

Colletotrichum cymbidiicola Damm, P.F. Cannon, Crous, P.R. Johnst. and B. Weir, *Stud. Mycol.* **73**: 19 (2012)

Colletotrichum cymbidiicola is known from *Cymbidium* (Orchidaceae) in Australia, New Zealand, Japan and India (Supplementary data 4, panel B) with endophytic behavior (Damm et al. 2012b), but also from the orchids *Bulbophyllum hirtum*, *Callostylis bambusifolia*, *Coelogyne* sp., *Dendrobium fimbriatum*, *Liparis viridiflora*, *Oncidium sphacealatum* and *Pinalia amica* in India causing anthracnose (Chowdappa et al. 2014). Considering the vast amount of species of *Colletotrichum* occurring on Orchidaceae, the conservation status of *C. cymbidiicola* prompts for caution.

Colletotrichum dacrycarpi Damm, P.F. Cannon, Crous, P.R. Johnst. and B. Weir, *Stud. Mycol.* **73**: 19 (2012)

Colletotrichum dacrycarpi, a morphologically and phylogenetically atypical *Colletotrichum* species, is known only from a single isolate collected as an endophyte on a *Dacrycarpus dacrydioides* (Podocarpaceae) leaf in New Zealand in 2009 (Damm et al. 2012b). There are no other records of *Colletotrichum* on *Dacrycarpus*, stressing that the conservation status of *C. dacrycarpi* is of great concern.

Colletotrichum doitungense X.Y. Ma, K.D. Hyde and Jayawardena, *MycoKeys* **43**: 23 (2018)

Colletotrichum doitungense is known from a single isolate collected epiphytically on *Dendrobium* sp. (Orchidaceae) in Thailand in 2013 (Ma et al. 2018). Considering the vast amount of species of *Colletotrichum* occurring on Orchidaceae, the conservation status of *C. doitungense* is of great concern.

Colletotrichum feijoicola Guarnaccia and Damm, *Persoonia* **42**: 291 (2019)

Colletotrichum feijoicola has recently been reported based on a single isolate, collected from *Acca sellowiana* (Myrtales) leaf spots from the Azores islands (Portugal) in 2017 (Crous et al. 2019b). Considering that several species of *Colletotrichum* have been reported from *Acca sellowiana*, the conservation status of *C. feijoicola* is of concern.

Colletotrichum hippeastri Yan L. Yang, Zuo Y. Liu, K. D. Hyde and L. Cai, *Fungal Divers.* **39**: 133 (2009)

The species *Colletotrichum hippeastri* was designated to accommodate fungi isolated from *Hippeastrum* (Amaryllidaceae) hosts in Brazil, China and the Netherlands (Damm et al. 2012b). Reports of anthracnose are scarce on *Hippeastrum* and no additional occurrences of *C. hippeastri* have been described, raising concern on the conservation status of this species.

Colletotrichum karsti Y.L. Yang, Zuo Y. Liu, K.D. Hyde and L. Cai, *Cryptog. Mycol.* **32**: 241 (2011)

Damm et al. (2012b) recognised *Colletotrichum karsti* from a number of hosts and regions (Supplementary data 4, panel C), including *Annona cherimola*, *Anthurium* sp., *Capsicum annuum*, *Carica papaya*, *Citrullus lanatus*, *Citrus* spp., *Clivia miniata*, *Coffea* spp., *Cucumis melo*, *Diospyros* spp., *Eucalyptus grandis*, *Eugenia uniflora*, *Gossypium hirsutum*, *Leucospermum* sp., *Lupinus albus*, *Malus* sp., *Mangifera indica*, *Musa* sp., *Pachira aquatica* (as *Bombax aquaticum*), *Passiflora edulis*, *Quercus salicifolia*, *Sclerocroton integerrimus*, *Solanum betaceum*, *S. lycopersicum*, *Stylosanthes* spp., *Synsepalum dulcificum*, *Theobroma cacao*, *Triticum* sp., and *Zamia obliqua*, along with orchid species, from where it was initially described (Youlian et al. 2011). The species was subsequently identified on *Alocasia macrorrhizos* and *Areca catechu* (Araceae) in China (He et al. 2014; Cao et al. 2020), *Bletilla ochracea* (Orchidaceae) in China (Tao et al. 2013), *Camellia* spp. (Theaceae) in China and Italy (Schena et al. 2014; Wang et al. 2016; Jiang and Li 2018), *Carissa macrocarpa* (= *C. grandiflora*; Apocynaceae) in Spain (García-Lopez et al. 2021), *Dendrobium nobile* (Orchidaceae) in Mexico (Fernández-Herrera et al. 2020), *Dracaena braunii* (as *D. sanderiana*, Asparagaceae) in China (Li et al. 2018a), *Elettaria cardamomum* (Zingiberaceae) in India (Chethana et al. 2016), *Fatsia japonica* (Araliaceae) in China (Xu et al. 2021), *Fragaria × ananassa* in Brazil (Soares et al. 2021), *Hevea brasiliensis* (Euphorbiaceae) in China (Cai et al. 2016a), *Hylocereus undatus* (Cactaceae) in Brazil (Nascimento et al. 2019b), *Litchi chinensis* (Sapindaceae) in China (Zhao et al. 2021c), *Malus domestica* (Rosaceae) in Brazil and Uruguay (Velho et al. 2014a, 2015), cassava (*Manihot esculenta*, Euphorbiaceae) in China (Liu et al. 2019a), *Morus alba* (Moraceae) in China (Xue et al. 2019), *Nandina domestica* (Berberidaceae) in China (Li et al.

2018b), olive (*Olea europaea*, Oleaceae) in Italy (Schena et al. 2014), avocado (*Persea americana*, Lauraceae) in Israel and Mexico (Velázquez-del Valle et al. 2016; Sharma et al. 2017), *Pistacia vera* (Anacardiaceae) in Italy and the USA (Schena et al. 2014; Lichtemberg et al. 2017), *Pyrus pyrifolia* (Rosaceae) in China (Fu et al. 2019), *Rubus glaucus* (Rosaceae) in Colombia (Afanador-Kafuri et al. 2014), *Taxus wallichiana* (Taxaceae) in China (Xu et al. 2019), *Vaccinium* sp. (Ericaceae) in Brazil (Rios et al. 2015) and *Vellozia gigantea* (Velloziaceae) in Brazil (Ferreira et al. 2017). *Colletotrichum karsti* is thus a cosmopolitan fungus, inhabiting a vast array of plant hosts.

Colletotrichum limonicola Guarnaccia and Crous, *Persoonia* **39**: 32 (2017)

Colletotrichum limonicola is known only from a single record, obtained from wither-tip twigs of lemon (*Citrus limon*, Rutaceae) in Malta in 2016 (Guarnaccia et al. 2017). Considering that there are numerous species of *Colletotrichum* occurring on citrus, the conservation status of *C. limonicola* is of great concern.

Colletotrichum novae-zelandiae Damm, P.F. Cannon, Crous, P.R. Johnst. and B. Weir, *Stud. Mycol.* **73**: 25 (2012)

Colletotrichum novae-zelandiae is known only from three isolates collected in New Zealand from chilli (*Capsicum annuum*, Solanaceae) and grapefruit (*Citrus* sp., Rutaceae) fruits in 1990 and 1988 respectively (Johnston and Jones 1997; Damm et al. 2012b). There are numerous species of *Colletotrichum* reported from each of these hosts and there are no further occurrences of *C. novae-zelandiae* ever since despite recent surveys, suggesting great concern on its conservation status.

Colletotrichum oncidii Damm, P.F. Cannon and Crous, *Stud. Mycol.* **73**: 26 (2012)

Colletotrichum oncidii is only known from an unspecified species of *Oncidium* (Orchidaceae), collected in 2010 in Germany (Damm et al. 2012b). There are no further occurrences of this species and there are many other species of *Colletotrichum* occurring on *Oncidium*, raising serious concerns over the conservation status of *C. oncidii* and rendering very difficult the deployment of surveys to ascertain its conservation status.

Colletotrichum parsonisiae Damm, P.F. Cannon, Crous, P.R. Johnst. and B. Weir, *Stud. Mycol.* **73**: 27 (2012)

There are two occurrences reported for *Colletotrichum parsonisiae*, as an endophyte on *Parsonsia capsularis* (Apocynaceae) leaves in New Zealand in 2009 (Damm et al. 2012b) and on healthy leaves of *Bletilla ochracea* (Orchidaceae) in China in 2006 (Tao et al. 2013). There are numerous species of *Colletotrichum* known from *Bletilla*, whereas there are no other reports from *Parsonsia*. Considering the scarcity of reports of *C. parsonisiae*, its conservation status can be considered of concern.

Colletotrichum petchii Damm, P.F. Cannon and Crous, *Stud. Mycol.* **73**: 29 (2012)

Colletotrichum petchii occurs on *Dracaena* (Asparagaceae), being reported from *D. alettriformis*, *D. brownii*, *D. fragrans* and *D. sanderiana*, in Australia, China, Germany, Italy and the Netherlands (Damm et al. 2012b; Shivas et al. 2016). Although reports of *C. petchii* range from the late nineteenth century to current times, spanning different hosts and locations (Supplementary data 4, panel D), the identification of other species of *Colletotrichum* on *Dracaena* advise periodic surveying to ascertain the conservation status of this species.

Colletotrichum phyllanthi (H.S. Pai) Damm, P.F. Cannon and Crous, *Stud. Mycol.* **73**: 31 (2012)

Damm et al. (2012b) reported *Colletotrichum phyllanthi* based on a single, non-sporulating fungal culture, obtained in 1966 in India from leaf anthracnose on *Phyllanthus acidus* (Phyllanthaceae) and stressed the absence of any further reports of this fungus. Moreover, a different species, *C. acidiae*, clustering in the truncatum complex, has been recently reported from *Phyllanthus acidus* (Samarakoon et al. 2018). However, recently *C. phyllanthi* was recorded to occur epiphytically on *Carapichea ipecacuanha* (Rubiaceae) in Brazil (Ferreira et al. 2020), prompting for further surveys to ascertain its distribution and hosts.

Colletotrichum torulosum Damm, P.F. Cannon, Crous, P.R. Johnst. and B. Weir, *Stud. Mycol.* **73**: 32 (2012)

Colletotrichum torulosum is known only from two isolates obtained in New Zealand from passionfruit (*Passiflora edulis*, Passifloraceae) in 2000 and eggplant (*Solanum melongena*, Solanaceae) in 1990 (Damm et al. 2012b). It is possible that this species also occurs on *Kunzea ericoides* (Myrtaceae) in New Zealand (Joshee et al. 2009; Damm et al. 2012b). Nevertheless, each of these three hosts harbor other species of *Colletotrichum* which, along the prolonged absence of new records for this species,

raises concerns on the conservation status of *Colletotrichum torulosum*.

Colletotrichum watphraense X.Y. Ma, K.D. Hyde and Jayawardena, *MycKeys* **43**: 35 (2018)

Colletotrichum watphraense was designated based on a single isolate obtained from healthy stems of an unspecified species of *Dendrobium* (Orchidaceae) in Thailand in 2013 (Ma et al. 2018). The occurrence of several species of *Colletotrichum* on *Dendrobium*, along with the absence of any further records of this fungus, raises serious concerns about the conservation status of *C. watphraense*.

The caudatum species complex

Colletotrichum caudatum was considered as one single species pathogenic of a broad range of warm-season grasses as traditional morphological approaches differentiate *C. caudatum* sensu lato from other *Colletotrichum* species by the presence of a unique filiform appendage at the apex of the conidium (Crouch 2014). However, multi-locus phylogenetic analyses reject the view of a single species and instead have shown that isolates from different hosts were mainly segregated into different lineages. Initially subdivided in five species pathogenic to grasses, the caudatum complex now includes eight species (Fig. 6), three of which described as endophyte of *Bletilla ochracea* (Orchidaceae) (Tao et al. 2013). Based on our knowledge, members of the caudatum complex have only been reported to be pathogenic or endophyte of monocot hosts. The caudatum species complex is a monophyletic group of species that fit within the graminicola species complex with which shares similar characteristics like the host specificity towards different lineages of monocot plants.

Colletotrichum alcornii J.A. Crouch, *IMA Fungus* **5**:27 (2014)

Colletotrichum alcornii is known from only two specimens, collected from *Bothriochloa bladhii* and *Imperata cylindrica* var. *major* (Poaceae) in close locations in Australia in 1972/73 (Crouch 2014; Shivas et al. 2016). The conservation status of this species is thus of concern.

Colletotrichum baltimoreense J.A. Crouch, *IMA Fungus* **5**: 27 (2014)

Colletotrichum baltimoreense is known only from *Sorghastrum nutans* (Poaceae), collected from a single location in the USA in 2011 (Crouch 2014). The pathological status of this fungus to indiagrass requires investigation and its conservation status is of concern.

Colletotrichum zoysiae J.A. Crouch, *IMA Fungus* **5**:27 (2014)

Colletotrichum zoysiae is known only from *Zoysia tenuifolia* (Poaceae) leaves, collected in Japan in 1998 (Crouch 2014). Although there are no other species of *Colletotrichum* reported from this host, the absence of any further records of *C. zoysiae* raises concern over its conservation status.

The dematium species complex

The dematium species complex was firstly introduced by Cannon et al. (2012) based on species designation assigned by Damm et al. (2009), as part of a study of *Colletotrichum* species with curved conidia. The type species of the genus, *C. lineola*, is part of this species complex (Damm et al. 2009). As defined initially by the authors, the dematium clade contained six species forming two clear and distinct subclades. However, the distinct separation in two clades pretty far from each other and the low support values based on the ITS sequences suggest that the two lineages are different complexes. In the past years the number of species in this complex has increased rapidly reaching 17 described lineages (Fig. 7). Geographically, members of this complex are typically origin from Europe or central Asia, several of which from Russia.

Members of the dematium species complex have been associated with 33 plant species belonging to 31 genera

belonging mainly to eudicots (27/31). *Colletotrichum dematium* has also been reported as capable of infecting human tissues such as cornea.

Colletotrichum anthrisci Damm, P.F. Cannon and Crous, *Fungal Divers.* **39**: 56 (2009)

There is a single record for *Colletotrichum anthrisci*, collected from *Anthriscus sylvestris* (Apiaceae) dead stems in the Netherlands in 2009, with unconfirmed pathogenicity (Damm et al. 2009). The host plant is widespread in temperate regions. The pathological behavior and conservation status of this species remains to be analysed.

Colletotrichum circinans (Berk.) Voglino, *Annali R. Accad. Agric. Torino* **49**: 175 (1907)

Besides being a pathogen of onion and other *Allium* spp., *Colletotrichum circinans* is also known from other hosts (*Anthriscus sylvestris*, *Beta vulgaris* and *Viola hirta*), in different parts of the world (Damm et al. 2009; Sato et al. 2015) (Supplementary data 5, panel A).

Colletotrichum dematium (Pers.) Grove, *J. Bot., Lond.* **56**: 341 (1918)

Colletotrichum dematium is known from several plant hosts in all continents (Supplementary data 5, panel B), either as a pathogen, a saprobe or an endophyte (Damm

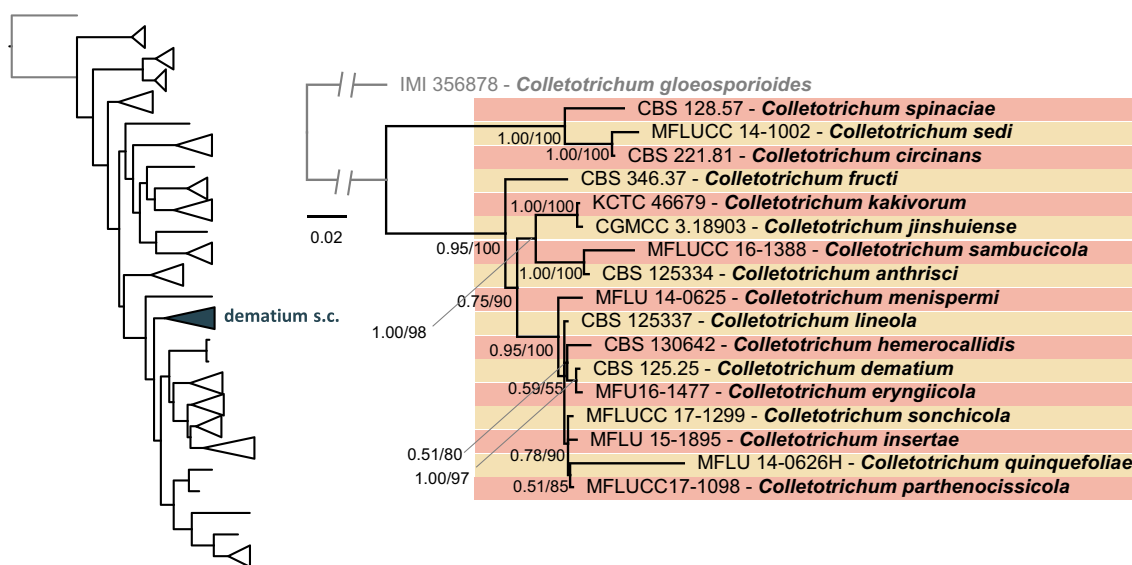

Fig. 7 Bayesian inference phylogenetic tree of the dematium species complex. The tree was reconstructed from a combined multi-locus sequence alignment (ITS, *gapdh*, *chs-1*, *his3*, *act* and *tub2*). For each locus the alignment was performed with MAFFT v7.450 (Katoh and Standley 2013), exported to MEGA7 (Kumar et al. 2016) and the best-fit substitution model calculated. Phylogenetic analyses were

performed with FastTree2 v2.1.10 (Price et al. 2010) and MrBayes 3.2.6 (Ronquist et al. 2012). Bayesian posterior probability (BPP) and Maximum-Likelihood (ML) bootstrap values (above 0.50) are reported next to the node. The scale bar represents the number of expected substitutions per site. GenBank accession numbers are listed in Supplementary file 1

et al. 2009; Jayawardena et al. 2016a), including reports as a human opportunistic pathogen (Valenzuela-Lopez et al. 2018; Buchta et al. 2019). Nevertheless, recent reports of *C. dematium* sensu Damm et al. (2009) are seldom [on *Polygonatum odoratum* (Asparagaceae) in Italy (Karimi et al. 2016), on *Asparagus racemosus* (Asparagaceae) and on *Hemidesmus indicus* (Apocynaceae) in India (Rather et al. 2018), on *Lycopus lucidus* (Lamiaceae) and on *Polygonum aviculare* (Polygonaceae) in China (Guan et al. 2016; Liu et al. 2016d) and on *Armeria maritima* (Plumbaginaceae) in Japan (Sato et al. 2015)], suggesting that the conservation status of *C. dematium* should be under survey.

Colletotrichum eryngiicola Jayaward., Bulgakov and K.D. Hyde, *Cryptog. Mycol.* **38**: 101 (2017)

Colletotrichum eryngiicola is known from a single isolate collected from *Eryngium campestre* (Apiaceae) in Russia in 2016 (Buyck et al. 2017). An additional species (*C. dematium*) has also been reported from this host, albeit both reports are very scarce, suggesting that the conservation status of *C. eryngiicola* is of concern.

Colletotrichum fructi (F. Stevans and J.G. Hall) Sacc., *Syll. fung.* (Abellini) **22**: 1201 (1913)

There are only two described occurrences of *Colletotrichum fructi*, both recorded in the USA on apple, in 1907 and 1937 (Damm et al. 2009). Given that several other species of *Colletotrichum* occur on apple and that many studies have been conducted on apple bitter rot pathogens worldwide, the conservation status of *C. fructi* is of great concern and this taxon may well be extinct from nature.

Colletotrichum hemerocallidis Yan L. Yang, Zuo Y. Liu, K.D. Hyde and L. Cai, *Trop. Plant Pathol.* **37**: 170 (2012)

Colletotrichum hemerocallidis is known from two isolates collected from dead stalks of *Hemerocallis fulva* var. *kwanso* (Xanthorrhoeaceae) in two locations in China in 2008 (Yang et al. 2012b). Considering the lack of any further reports of this fungus and the occurrence of other species of *Colletotrichum* on *Hemerocallis* spp., the conservation status of this species is of concern.

Colletotrichum insertae Jayawardena, Bulgakov and K.D. Hyde, *Fungal Divers.* **80**: 176 (2016)

Colletotrichum insertae is only known from *Parthenocissus inserta* (Vitaceae) in Russia, where it was collected in 2015 as a saprobe on dying twigs and leaves (Hyde et al. 2016). There are several species of *Colletotrichum* recorded from *Parthenocissus*, rendering the conservation status of *C. insertae* of serious concern.

Colletotrichum jinshuiense M. Fu and G.P. Wang, *Persoonia* **42**: 1 (2019)

Colletotrichum jinshuiense is known only from *Pyrus pyrifolia* (Rosaceae) leaves, collected in China in 2016 (Fu et al. 2019). This single occurrence, along with the high number of species of *Colletotrichum* reported from pear, calls for concern on the conservation status of *C. jinshuiense*.

Colletotrichum kakiivorum H.Y. Jung and S.Y. Lee, *Mycol. Prog.* **17**: 1113-1121 (2018)

Colletotrichum kakiivorum is known from two occurrences associated with leaf spots in persimmon (*Diospyros kaki*, Ebenaceae) in Korea in 2016 (Lee and Jung 2018). There are several species of *Colletotrichum* occurring on persimmon, including in Korea, rendering the conservation status of *C. kakiivorum* of concern.

Colletotrichum lineola Corda, in Sturm, *Deutschl. Fl.*, 3 Abt. (Pilze Deutschl.) **3** (12): 41 (1831)

Colletotrichum lineola, the type species of the genus *Colletotrichum*, occurs as a pathogen or as a saprobe on a large number of host plants and locations (Jayawardena et al. 2016a). In a study on *Colletotrichum* spp. with curved conidia in Japan, Sato et al. (2015) found *Colletotrichum lineola* on *Dianthus* sp. and *Saponaria officinalis* (Caryophyllaceae), *Helleborus niger* (Ranunculaceae), *Isotoma axillaris* (Campanulaceae), *Sanguisorba officinalis* (Rosaceae), *Taraxacum campylodes* (Asteraceae) and *Vigna angularis* (Fabaceae). More recently, Guarnaccia et al. (2021) reported *C. lineola* from *Campanula trachelium* (Campanulaceae) in Italy. *Colletotrichum lineola* is thus a common fungus worldwide, but apparently with low host preference.

Colletotrichum menispermii Chethana, Jayawardena, Bulgakov and K.D. Hyde, *Fungal Divers.* **78**: 80 (2016)

The species *Colletotrichum menispermii* was described based on an isolate obtained from dead twigs of *Menispermum dauricum* (Menispermaceae) in Russia in 2014 (Li et al. 2016c). There are no additional records for this fungus nor other reports of *Colletotrichum* from this host, indicating that the conservation status of this fungus is of serious concern.

Colletotrichum parthenocissicola Jayawardena, Bulgakov, Huanraleuk & K.D. Hyde *Fungal Divers.* **104**: 1 (2020)

Colletotrichum parthenocissicola is known only from dying and dead twigs and petioles of *Parthenocissus quinquefolia*

(Vitaceae) in Russia in 2016 (Yuan et al. 2020). The absence of additional records for this species and the occurrence of other species of *Colletotrichum* on *Parthenocissus* raises severe concerns about the conservation status of *C. parthenocissicola*.

Colletotrichum quinquefoliae Jayawardena, Bulgakov and K.D. Hyde, *Fungal Divers.* **78**: 83 (2016)

Colletotrichum quinquefoliae is known only from dying and dead leafstalks, twigs and tendrils of *Parthenocissus quinquefolia* (Vitaceae) in Russia in 2014 (Li et al. 2016c). The absence of additional records for this species and the occurrence of other species of *Colletotrichum* on *Parthenocissus* raises severe concerns about the conservation status of *C. quinquefoliae*.

Colletotrichum sambucicola Jayawardena, Camporesi and K.D. Hyde, *Fungal Divers.* **83**: 131 (2017)

There is a single fungus known from the species *Colletotrichum sambucicola*, isolated from a dead branch of *Sambucus ebulus* (Adoxaceae) in Italy in 2016 (Tibpromma et al. 2017). There are no further references to this species and there are other species of *Colletotrichum* identified from *Sambucus*, raising serious concerns about the conservation status of *C. sambucicola*.

Colletotrichum sedi Jayawardena, Bulgakov and K.D. Hyde, *Fungal Divers.* **72**:27 (2015)

Colletotrichum sedi is known only from a single occurrence, obtained from an unspecified species of *Sedum* (Crassulaceae) in Russia in 2014 (Liu et al. 2015b). The absence of additional reports for this fungus and the occurrence of other species of *Colletotrichum* on *Sedum* raise severe concerns about the conservation status of *C. sedi*.

Colletotrichum sonchicola Jayawardena, Camporesi and K.D. Hyde, *Phytotaxa* **314**: 55 (2017)

The species *Colletotrichum sonchicola* was described based on a single isolate collected from dead stems of an unspecified species of *Sonchus* (Asteraceae) in Italy in 2016 (Jayawardena et al. 2017). Although no further species of *Colletotrichum* are known to inhabit *Sonchus*, the absence of any further records for *C. sonchicola* raises serious concerns about its conservation status.

Colletotrichum spinaciae Ellis and Halst., *J. Mycol.* **6**: 34 (1890)

Initially treated as a specific pathogen of spinach (*Spinacea oleracea*, Amaranthaceae), *Colletotrichum spinaciae* sensu Damm et al. (2009) is recognised as occurring also on *Chenopodium album* (Amaranthaceae), *Portulaca oleracea* (Portulacaceae) and *Medicago sativa* (Fabaceae) in Europe and North America. More recently the fungus was reported on spinach in Turkey and Australia (Kurt et al. 2016; Shivas et al. 2016) and on *Medicago sativa* in China (Wang et al. 2019c). *Colletotrichum spinaciae* thus seems to be a common fungus.

The destructivum species complex

The destructivum aggregate was firstly introduced by Cannon et al. (2012) as a monophyletic group of six important plant pathogenic species: *Colletotrichum destructivum*, *C. fuscum*, *C. tabacum*, *C. linicola*, *C. higginsianum* and *Glomerella truncata*. Two years later, Damm et al. (2014) described the destructivum species complex encompassing the six previously mentioned species (with *G. truncata* renamed as *C. lentis*) and 10 closely related ones. Nowadays the complex has a total of 20 species (Fig. 8) and among them *C. destructivum*, *C. lini* and *C. higginsianum* are the most common ones whereas the others are pretty rare.

Members of the destructivum species complex have been associated with 49 plant species belonging to 41 genera; the vast majority of these (37/41, 90%) are eudicots. Beside the economic impact of these pathogens, the species belonging to the destructivum complex such as *C. higginsianum* are important model systems that have been successfully used to advance the knowledge of the molecular basis of plant pathogenicity (O'Connell et al. 2012; Bhadauria et al. 2019).

Colletotrichum americae-borealis Damm, *Stud. Mycol.* **79**: 55 (2014)

Originally described on *Medicago sativa* from the USA (Damm et al. 2014), *Colletotrichum americae-borealis* has recently been recorded in Iran as a pathogen on *Tragopogon graminifolius* (Asteraceae), *Convolvulus arvensis* (Convolvulaceae), *Heracleum persicum* (Apiaceae) and *Sorghum halepense* (Poaceae) (Khodaei et al. 2019) and in China also on *Medicago sativa* (Kemei et al. 2021), suggesting a pluricontinental distribution and polyphagous behaviour.

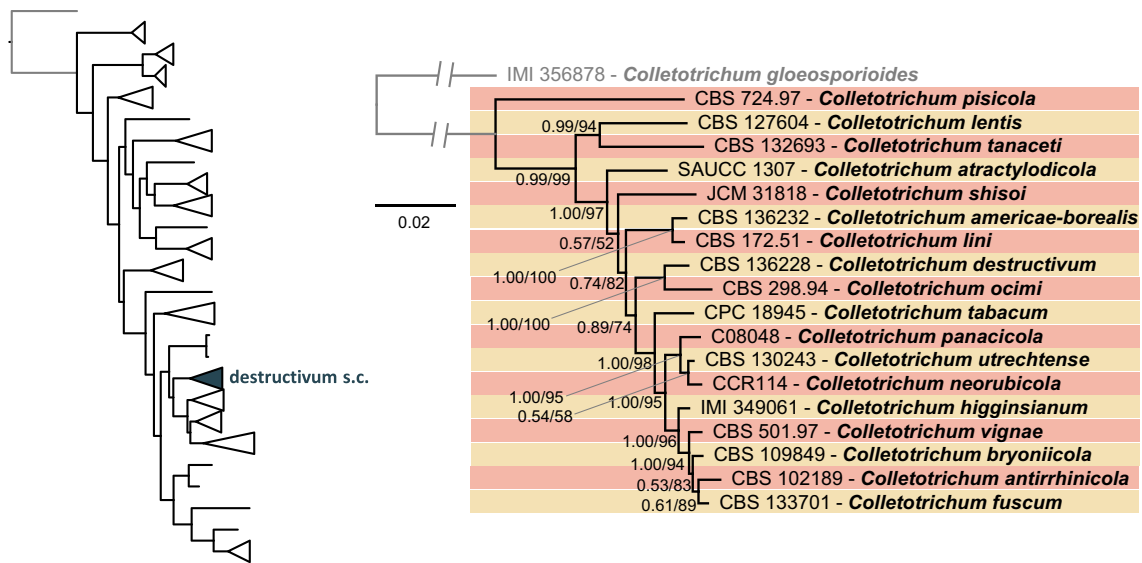

Fig. 8 Bayesian inference phylogenetic tree of the destructivum species complex. The tree was reconstructed from a combined multi-locus sequence alignment (ITS, *gapdh*, *chs-1*, *his3*, *act* and *tub2*). For each locus the alignment was performed with MAFFT v7.450 (Kato and Standley 2013), exported to MEGA7 (Kumar et al. 2016) and the best-fit substitution model calculated. Phylogenetic analy-

ses were performed with FastTree2 v2.1.10 (Price et al. 2010) and MrBayes 3.2.6 (Ronquist et al. 2012). Bayesian posterior probability (BPP) and Maximum-Likelihood (ML) bootstrap values (above 0.50) are reported next to the node. The scale bar represents the number of expected substitutions per site. GenBank accession numbers are listed in Supplementary file 1

Colletotrichum antirrhinicola Damm, *Stud. Mycol.* **79**: 56 (2014)

There is a single record for *Colletotrichum antirrhinicola*, collected from snap dragon (*Antirrhinum majus*, Plantaginaceae) leaves in New Zealand in 1999, with unconfirmed pathogenicity (Damm et al. 2014). The host plant is of widespread use as an ornamental. The pathological behaviour and conservation status of this species remains to be analysed. Anthracnose, attributed to *Colletotrichum* pathogens, is a common disease of snap dragon, but most of the literature lacks recent reports that may establish a clear link between this disease and *C. antirrhinicola*. In 2011, Tomioka et al. (2011) analysed the causal agents of snap dragon anthracnose in Japan, but these fungi can be attributed to *C. higginsianum*.

Colletotrichum atractylodocola R.J. Zhou and H.J. Xu, *Mycol. Prog.* **17**: 393 (2018)

There is a single record for *Colletotrichum atractylodocola*, collected from *Atractylodes lancea* (as *A. chinensis*, Asteraceae) in China in 2013 (Xu et al. 2018b). There are various species of *Colletotrichum* occurring on *Atractylodes*, rendering the pathological status of *C. atractylodocola* uncertain and its conservation status of concern.

Colletotrichum bryoniicola Damm, *Stud. Mycol.* **79**: 57 (2014)

There are two isolates of *Colletotrichum bryoniicola*, collected from decaying leaves of *Bryonia cretica* subsp. *dioica* (Cucurbitaceae) in the Netherlands in 2001 (Damm et al. 2014) and from anthracnose symptoms on *Salvia nemerosa* (Lamiaceae) in Italy in 2018 (Guarnaccia et al. 2019). The pathological and conservation status of *C. bryoniicola* is uncertain and of concern.

Colletotrichum destructivum O'Gara, *Mycologia* **7**: 38 (1915)

Colletotrichum destructivum is found as a pathogen on numerous botanical families, mostly dicotyledonous, throughout the world, being recurrently reported (Supplementary data 6, panel A). Hosts of *C. destructivum* include: *Cynanchum atratum* (Apocynaceae; Miao et al. 2017); *Aster tataricus* and *Helianthus annuus* (Asteraceae; Cong et al. 2018; Sun and Liang 2018); *Echium italicum* (Boraginaceae; Khodaei et al. 2019); *Medicago sativa*, *M. scutellata* and *Trifolium* spp. (Fabaceae; Damm et al. 2014; Shivas et al. 2016; Xue et al. 2018b); *Ocimum basilicum* and *Thymus vulgaris* (Lamiaceae; Mosca et al. 2014; Fu et al. 2015);

Bletilla ochracea (Orchidaceae; Tao et al. 2013); *Phragmites* sp. (Poaceae; Damm et al. 2014); *Rumex crispus* (Polygonaceae; Liu et al. 2017b); *Viola odorata* (Violaceae; Katoch et al. 2017).

Colletotrichum fuscum Laubert, *Gartenwelt* **31**: 675 (1927)

Colletotrichum fuscum is known from Germany and the Netherlands on several species of *Digitalis* (Plantaginaceae) and on an unspecified species of *Heracleum* (Apiaceae) (Damm et al. 2014). It was also recently reported from Italy on *Coreopsis lanceolata* (Asteraceae) (Guarnaccia et al. 2021). There are no other species of *Colletotrichum* recorded from *Digitalis* or *Coreopsis* and additional reports of anthracnose on these hosts suggest the presence of the fungus in Poland and the UK (Zimowska et al. 2016; Cannon 2019). The apparent host specificity and relatively narrow geographic distribution of *C. fuscum* recommend caution concerning its conservation status.

Colletotrichum higginsianum Sacc., *Riv. Accad. Padova* **33**: 161 (1917)

Damm et al. (2014) described *Colletotrichum higginsianum* as a taxon of pathogens of Brassicaceae. Recent reports are scarce and refer to hosts other than Brassicaceae, namely *Campanula* sp. (Campanulaceae) in Iran (Khodaei et al. 2019) and *Rumex acetosa* (Polygonaceae) in China (Zhang et al. 2018b). These observations suggest that the current host range and geographical distribution of *C. higginsianum* should be further investigated (Supplementary data 6, panel B).

Colletotrichum lentis Damm, *Stud. Mycol.* **79**: 65 (2014)

Colletotrichum lentis was designated by Damm et al. (2014) to accommodate fungi infecting lentil (*Lens culinaris*, Fabaceae) occurring in Canada and Romania. The fungus was subsequently reported from common vetch (*Vicia sativa*, Fabaceae) in China (Xu and Li 2015). This fungus seems to be host specific and is commonly found causing lentil anthracnose.

Colletotrichum lini (Westerd.) Tochinai, *J. Coll. agric., Hokkaido Imp. Univ.* **14**(4): 176 (1926)

Colletotrichum lini is known from flax (*Linum usitatissimum*, Linaceae), alfalfa (*Medicago sativa*) and *Trifolium* spp. (Fabaceae), *Raphanus raphanistrum* (Brassicaceae) and

Teucrium scorodonia (Lamiaceae) (Damm et al. 2014). Nevertheless, the fungus is infrequently reported, recommending surveys to ascertain its conservation status (Supplementary data 6, panel C).

Colletotrichum neorubicola Yu Li, J. Gao & L. P. Liu, *Mycol. Prog.* **19**:947-955 (2020)

This species comprises isolates obtained from *Rubus idaeus* (Rosaceae) in 2013 in China causing leaf anthracnose (Liu et al. 2020c). No additional fungi have been added to this species and several species of *Colletotrichum* are known from *Rubus* spp., rendering the conservation status of *C. neorubicola* of concern.

Colletotrichum ocimi Damm, *Stud. Mycol.* **79**: 70 (2014)

Colletotrichum ocimi is associated to anthracnose of basil (*Ocimum basilicum*, Lamiaceae), and has been reported from Italy (Damm et al. 2014; Guarnaccia et al. 2019; Cacciola et al. 2020) and Australia (Shivas et al. 2016). The knowledge on the geographic distribution of *C. ocimi* requires further investigation to ascertain its pathological relevance and ecological status.

Colletotrichum orchidis Jayaward., Camporesi and K.D. Hyde, *Mycosphere* **11**: 305 (2020)

Colletotrichum orchidis is known from a single isolate obtained from an aerial stem of an unspecified species of *Orchis* (Orchidaceae) in Italy (Hyde et al. 2020b). There are no additional records of this fungus and there are many species of *Colletotrichum* reported from orchids, raising serious concerns on the conservation status of *C. orchidis*.

Colletotrichum panacicola Uyeda and S. Takim., *Chosen Nokai-ho* **14**: 24 (1919)

Colletotrichum panacicola is associated to anthracnose on *Panax ginseng* (Araliaceae) in China, Japan, Korea and Russia (Choi et al. 2011; Damm et al. 2014). The fungus appears to be host specific and to occur in Eastern Asia.

Colletotrichum pisicola Damm, *Stud. Mycol.* **79**: 71 (2014)

Colletotrichum pisicola is known from pea (*Pisum sativum*, Fabaceae) in America (Ecuador, Mexico, Puerto Rico and the USA) (Damm et al. 2014), but all reports are old. The lack of recent occurrences of *C. pisicola* raise serious concerns about its conservation status, suggesting that this taxon may no longer occur in nature.

Colletotrichum pleopeltidis Crous & Jol. Roux, *Fungal Syst. Evol.* **7**:285 (2021)

Colletotrichum pleopeltidis is known only from a single occurrence on leaves of an unspecified species of the fern *Pleopeltis*, collected in 2015 in South Africa (Crous et al. 2021). There are no details regarding the lifestyle of this fungus and its conservation status is of concern.

Colletotrichum shisoi P. Gan, A. Tsushima, M. Kawaradani, Damm and K. Shirasu, *Sci. Rep.* **9**: 13349 (2019)

Colletotrichum shisoi is known only from anthracnose symptoms in *Perilla frutescens* (Lamiaceae) in Japan, where it was collected in 2006 (Gan et al. 2019). There have been no additional reports of *C. shisoi*, raising serious concerns over the conservation status of this taxon.

Colletotrichum tabacum Böning, *Prakt. Bl. Pflanzenbau Pflanzenschutz* **10**: 89 (1932)

Colletotrichum tabacum sensu Damm et al. (2014) is a species occurring on tobacco (*Nicotiana* spp., Solanaceae) as well as on *Centella asiatica* (Apiaceae). The latter seems to be the most recent report of this fungus, dating from 2003 from Madagascar. There are no recent reports of the occurrence of *C. tabacum* other than its use in artificial inoculation experiments, as stressed by Damm et al. (2014), raising serious concerns on the conservation status of this species.

Colletotrichum tanacetii M. Barimani, S.J. Pethybridge, N. Vaghefi, F.S. Hay and P.W.J. Taylor, *Plant Pathol.* **62**: 1248–1257 (2013)

Colletotrichum tanacetii is known to occur across the cultivation area of *Tanacetum cinerariifolium* (Asteraceae) in Australia (Barimani et al. 2013; Damm et al. 2014; Lelwala et al. 2019). The fungus appears to be host specific and may become of quarantine relevance.

Colletotrichum utrechtense Damm, *Stud. Mycol.* **79**: 77 (2014)

Colletotrichum utrechtense is known from a single isolate, obtained from leaves of *Trifolium pratense* (Fabaceae) in the Netherlands in 2011 (Damm et al. 2014). Several other species of *Colletotrichum* are known from *Trifolium* and there are no other records of *C. utrechtense*, raising serious concerns about the conservation status of this taxon.

Colletotrichum vignae Damm, *Stud. Mycol.* **79**: 78 (2014)

Colletotrichum vignae is known only from a single record obtained from cowpea (*Vigna unguiculata*, Fabaceae) in Nigeria prior to 1997 (Damm et al. 2014). The occurrence of several other species of *Colletotrichum* on *Vigna* and the absence of any other records of *C. vignae*, raise serious concerns about the conservation status of this fungal taxon, which may no longer exist in nature.

The dracaenophilum species complex

Together with the agaves, magnum and the orchidearum complexes, the dracaenophilum complex is one of the most recently described species complexes (Damm et al. 2019). The dracaenophilum species complex encompasses eight species distributed in the northern hemisphere (Asia, Europe and Mexico). Species belonging to this complex have been associated with nine plant species belonging to seven genera in monocots and eudicots. Due to the low number of representative isolates for each species, almost every lineage shows a certain level of specificity towards one genus, however more studies are needed to confirm the level of host preference (Fig. 9).

Colletotrichum cariniferi X.Y. Ma, K.D. Hyde and Jayawardena, *MycKeys* **43**: 23 (2018)

Colletotrichum cariniferi is known only from *Dendrobium cariniferum* (Orchidaceae), collected from stems in Thailand in 2013 (Ma et al. 2018). The pathological relevance and conservation status of this species remains to be analysed.

Colletotrichum coelogyne Damm, *Stud. Mycol.* **92**: 1 (2019)

Colletotrichum coelogyne is known from a single isolate, obtained from *Coelogyne* sp. (Orchidaceae) leaves in Germany in 2010 (Damm et al. 2019). Another species, *C. cymbidiicola*, is also known from *Coelogyne*, raising concern on the conservation status of *C. coelogyne*.

Colletotrichum dracaenophilum D.F. Farr and M.E. Palm, *Mycol. Res.* **110**: 1401 (2006)

Colletotrichum dracaenophilum is only known from *Dracaena* (*D. sanderiana* and *D. braunii*) in Brazil, Bulgaria, Egypt, China and Australia (Macedo and Barreto 2016; Morsy and Elshahawy 2016; Shivas et al. 2016; Damm et al. 2019) (Supplementary data 7). Other species of *Colletotrichum* are known from *Dracaena*, indicating that the conservation status of *C. dracaenophilum* should be under surveillance.

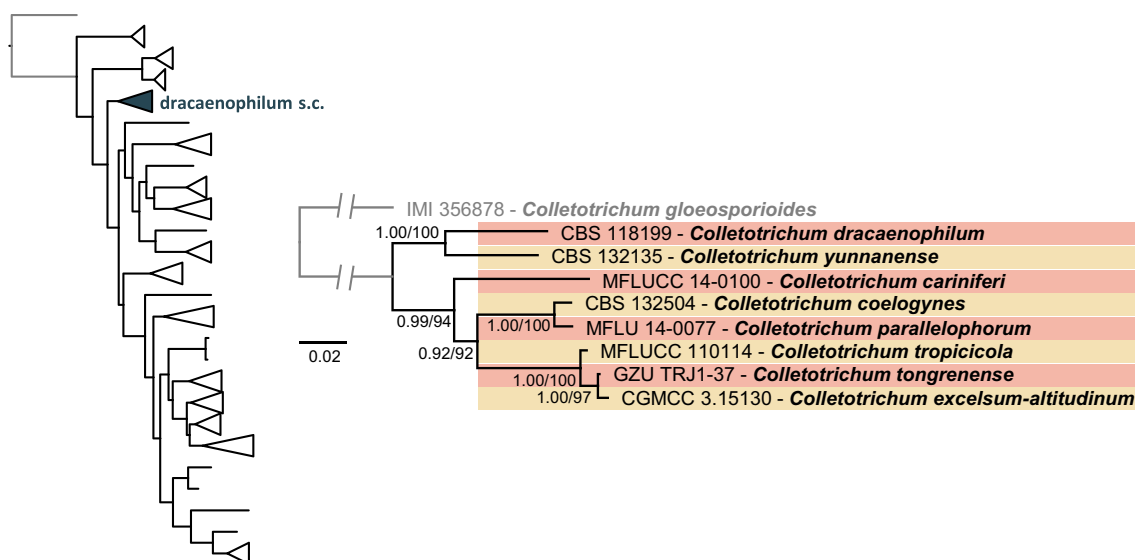

Fig. 9 Bayesian inference phylogenetic tree of the dracaenophilum species complex. The tree was reconstructed from a combined multi-locus sequence alignment (ITS, *gapdh*, *chs-1*, *his3*, *act* and *tub2*). For each locus the alignment was performed with MAFFT v7.450 (Kato and Standley 2013), exported to MEGA7 (Kumar et al. 2016) and the best-fit substitution model calculated. Phylogenetic analy-

ses were performed with FastTree2 v2.1.10 (Price et al. 2010) and MrBayes 3.2.6 (Ronquist et al. 2012). Bayesian posterior probability (BPP) and Maximum-Likelihood (ML) bootstrap values (above 0.50) are reported next to the node. The scale bar represents the number of expected substitutions per site. GenBank accession numbers are listed in Supplementary file 1

Colletotrichum excelsum-altitudinum G. Tao, Zuo Y. Liu and L. Cai, *Fungal Divers.* **61**: 152 (2013)

Colletotrichum excelsum-altitudinum is only known from a single isolate collected from healthy *Bletilla ochracea* (Orchidaceae) leaves in China in 2006, along with several other species of *Colletotrichum* (Tao et al. 2013). Many species of *Colletotrichum* occur on this host and even more on orchids in general, most epiphytically, rendering the conservation status of *Colletotrichum excelsum-altitudinum* of great concern.

Colletotrichum parallelophorum X.Y. Ma, K.D. Hyde and Jayawardena, *MycKeys* **43**: 23 (2018)

This species is recorded only from an epiphytic fungus occurring on an unspecified species of *Dendrobium* (Orchidaceae) in Thailand in 2013 (Ma et al. 2018). There are no additional reports of this fungus and many other species of *Colletotrichum* occur on *Dendrobium*, raising serious concerns on the conservation status of *C. parallelophorum*.

Colletotrichum tongrenense S.X. Zhou, J.C. Kang and K.D. Hyde, *MycKeys* **49**: 1 (2009)

Colletotrichum tongrenense is known from a single isolate, obtained from symptomless leaves and stems of *Nothapodytes pittosporoides* (Icacinaceae) in China (Zhou et al. 2019). The ecological and conservation status of *Colletotrichum tongrenense* is unknown and of concern.

Colletotrichum tropicicola Phouliv., Noireung, L. Cai and K.D. Hyde, *Cryptog. Mycol.* **33**: 353 (2012)

Colletotrichum tropicicola was designated based on two endophytic occurrences reported from Thailand in 2009 on leaves of *Citrus maxima* (Rutaceae) and *Paphiopedilum bellatulum* (Orchidaceae) (Noireung et al. 2012). Damm et al. (2019) identified isolates obtained from *Citrus* sp. in Mexico as belonging to *Colletotrichum tropicicola*, along with the Thai isolate from *Citrus maxima*, suggesting that the *Paphiopedilum bellatulum* isolate may lay in a separate, undescribed species. *Colletotrichum tropicicola* is still in a phase of delimitation, and consequently its ecological and conservation statuses need clarification.

Colletotrichum yunnanense Xiao Ying Liu and W.P. Wu, *Mycotaxon* **100**: 139 (2007)

Colletotrichum yunnanense was described based on an isolate obtained from healthy leaves of an unspecified species of *Buxus* (Buxaceae) in China in 2004 (Liu et al. 2007; Weir et al. 2012), but no additional records have been reported ever since and reports of *Colletotrichum* from *Buxus* are seldom. The current conservation status of *C. yunnanense* is therefore of concern.

The gigasporum species complex

The gigasporum species complex (Fig. 10) was firstly described by Liu et al. (2014) encompassing six species. *Colletotrichum gigasporum* was identified and named based the formation of large (> 20 µm-long) conidia distinct from other currently known *Colletotrichum* species and confirmed by multi-locus phylogenetic analyses (ITS, *act*, *tub2*, *chs-1* and *gapdh*). Recently three new members of this complex have been described: *C. serranegrense*, endophytic of *Cattleya jongheana* in Brazil (Silva et al. 2018), and *C. jishouense* and *C. chiangraiense*, endophytic species of *Nothapodytes pittosporoides* and *Dendrobium* sp. respectively in China (Ma et al. 2018; Zhou et al. 2019), although we exclude *C. chiangraiense* from the list of accepted species based on incongruence of the nucleotide sequence of the type strain (whereas the ITS sequence places this taxon

in the boninense complex, the *act* and *tub2* sequences place it in the gigasporum complex) as detailed in “Geographical distribution of *Colletotrichum* occurrences” section. Whereas *C. serranegrense* and *C. jishouense* have been described as members of the gigasporum species complex, *C. chiangraiense* has been described as a basal species of the boninense species complex, highlighting differences in the ITS clustering compared to the other genes. Further analyses will be needed to confirm the situation of *C. chiangraiense*. Species in the gigasporum complex have seldomly been reported (still *C. gigasporum* is the most common species), making this complex the less common of the genus.

Colletotrichum arxii F. Liu, L. Cai, Crous and Damm, *Perseonia* **33**: 87 (2014)

Colletotrichum arxii is known only from two isolates collected in Europe in the orchids *Paphiopedilum* sp. and *Oncidium excavatum* in 2010 and before 1956 respectively (Liu et al. 2014). There are multiple species of *Colletotrichum* inhabiting orchids, raising concern on the current conservation status of *C. arxii*.

Colletotrichum gigasporum E.F. Rakotoniriana and F. Munaut, *Mycol. Prog.* **12**: 407 (2013)

Colletotrichum gigasporum occurs on several hosts, mostly in tropical regions across the globe (Rakotoniriana et al.

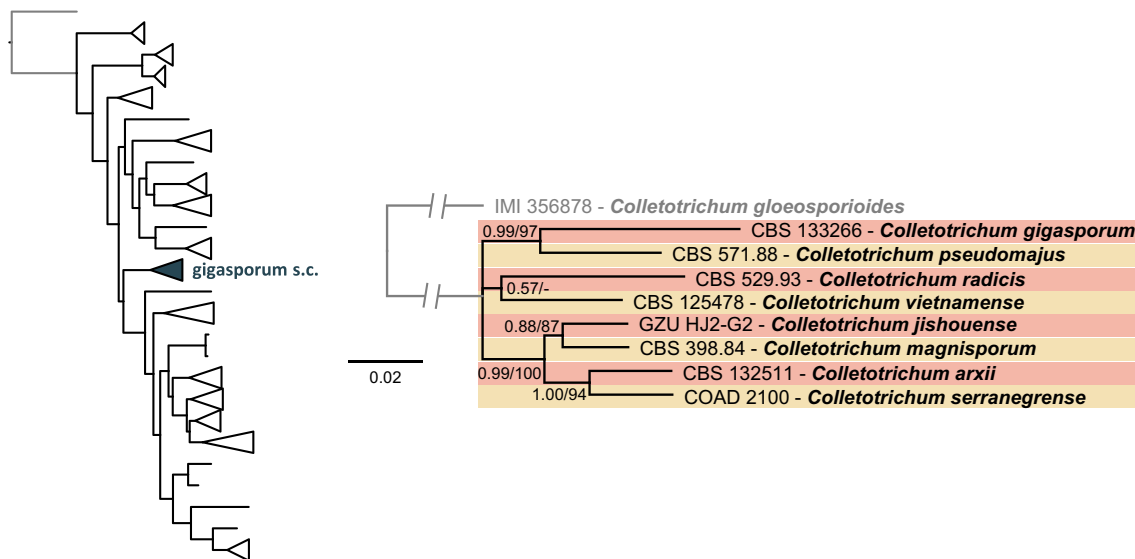

Fig. 10 Bayesian inference phylogenetic tree of the gigasporum species complex. The tree was reconstructed from a combined multi-locus sequence alignment (ITS, *gapdh*, *chs-1*, *his3*, *act*, *tub2* and *gs*). For each locus the alignment was performed with MAFFT v7.450 (Kato and Standley 2013), exported to MEGA7 (Kumar et al. 2016) and the best-fit substitution model calculated. Phylogenetic analy-

ses were performed with FastTree2 v2.1.10 (Price et al. 2010) and MrBayes 3.2.6 (Ronquist et al. 2012). Bayesian posterior probability (BPP) and Maximum-Likelihood (ML) bootstrap values (above 0.50) are reported next to the node. The scale bar represents the number of expected substitutions per site. GenBank accession numbers are listed in Supplementary file 1

2013) (Supplementary data 8). Studies targeting the analysis of population frequency of *Colletotrichum* anthracnose pathogens on diverse hosts all coincide in revealing *C. gigasporum* as a secondary pathogen, including on *Annona* spp. in Brazil (Costa et al. 2019), coffee in Mexico (Cristóbal-Martínez et al. 2017) and in China (Cao et al. 2019a) and mango in China (Li et al. 2019b), prompting regular surveys to ascertain the conservation status of this species.

Colletotrichum jishouense SX. Zhou, JC. Kang and K.D. Hyde, *MycKeys* **49**: 1 (2019)

Colletotrichum jishouense has been recorded only from healthy roots of *Nothapodytes pittosporoides* (Icacaceae), in China in 2016 (Zhou et al. 2019). Further research is needed to ascertain the host and geographic distribution of this taxon, as there is concern regarding its current conservation status.

Colletotrichum magnisporum F. Liu, L. Cai, Crous and Damm, *Persoonia* **33**: 91 (2014)

Colletotrichum magnisporum is an enigmatic fungus, collected prior to 1984 from an unknown source (Liu et al. 2014). There are no additional records for this fungus, although metagenomics data suggest its occurrence in nature (Jayawardena et al. 2016a). Under these circumstances, the conservation status of *C. magnisporum* is of great concern and further surveys are needed to ascertain its occurrence on nature.

Colletotrichum pseudomajus F. Liu, L. Cai, Crous and Damm, *Persoonia* **33**: 91 (2014)

Colletotrichum pseudomajus is known only from a single isolate, collected from *Camellia sinensis* (Theaceae) in China at an unknown date (prior to 1988) (Liu et al. 2014). The absence of any further records of this species and the occurrence of several species of *Colletotrichum* on *Camellia* spp. render the conservation status of *C. pseudomajus* of serious concern, with extinction from nature as a plausible scenario for this species.

Colletotrichum radialis F. Liu, L. Cai, Crous and Damm, *Persoonia* **33**: 93 (2014)

There is a single isolate in the species *Colletotrichum radialis*, obtained from a root of an undetermined host in Costa Rica in 1993 (Liu et al. 2014). The scarcity of information on the ecological context of its isolation and the absence of any other records for this species hamper further surveys and strongly suggest that *Colletotrichum radialis* may be extinct from nature.

Colletotrichum serranegrense Meir. Silva & M.C.M. Kasuya, *Phytotaxa* **351**: 163 (2018)

This species is known only from a single location, collected in Brazil in 2015 as a root endophyte of the endangered orchid *Cattleya jongheana* (Silva et al. 2018). Several other species of *Colletotrichum* have been obtained from *Cattleya* spp., rendering the conservation status of *C. serranegrense* of concern.

Colletotrichum vietnamense F. Liu, L. Cai, Crous and Damm, *Persoonia* **33**: 93 (2014)

Colletotrichum vietnamense is known only from two isolates obtained from anthracnose symptoms on leaves of *Coffea* sp. (Rubiaceae) in Vietnam at an unknown date (Liu et al. 2014). The absence of any additional records of this taxon and the occurrence of several other species of *Colletotrichum* on *Coffea* raise serious concerns about the conservation status of *C. vietnamense*.

The gloeosporioides species complex

Like the acutatum complex, the gloeosporioides species complex was considered as one unique morphologically and phylogenetically diverse species. The name *Colletotrichum gloeosporioides* was firstly proposed in Penzig (1882), based on *Vermicularia gloeosporioides*, the type specimen of which was collected from *Citrus* in Italy. In the past century the term *Colletotrichum gloeosporioides* has undergone several usages and different taxonomists have kept agglomerating or dividing species under this name according with the evolution of the species concept. The revision performed by Weir et al. (2012) was a breakthrough in the taxonomy of this group and 22 species plus one subspecies were accepted as member of the gloeosporioides species complex. Nevertheless, the complex has undergone recurrent changes and several lineages have been merged and separated into novel species since then. One good example of the level of instability is provided by *C. siamense*. From 2009 to 2014, seven species with close phylogenetic affinities to *C. siamense* have been described and in some cases considered as species within *C. siamense* sensu lato (Liu et al. 2016c). Whereas some of these species (i.e. *C. hymenocallidis* and *C. jasminisambac*) were synonymised with *C. siamense* sensu stricto based on Weir et al. (2012), other authors resurrected those names describing *C. siamense* as a species complex. These changes have led to substantial disagreements regarding the taxonomy of this group. Finally, Liu et al. (2015a) used multiple approaches to demonstrate the lack of recognition of any independent evolutionary lineages within *C. siamense* sensu lato as distinct species, thus rejecting the null hypothesis. To date, 57 species have been described (Fig. 11) and

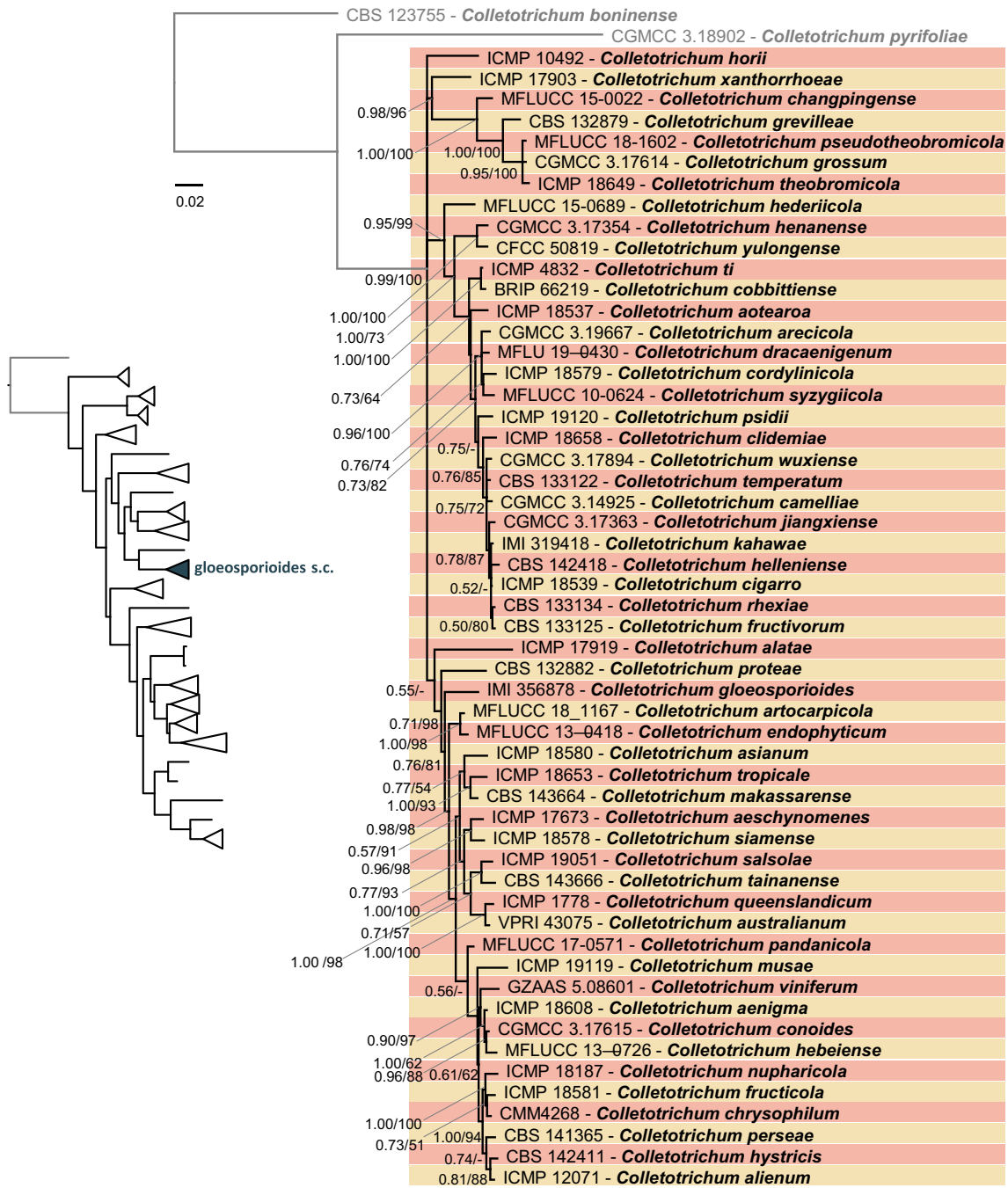

Fig. 11 Bayesian inference phylogenetic tree of the gloeosporioides species complex and closely related singleton species. The tree was reconstructed from a combined multi-locus sequence alignment (ITS, *gapdh*, *chs-1*, *act*, *tub2*, *cal*, *gs*, *sod2* and *ApMat*). For each locus the alignment was performed with MAFFT v7.450 (Katoh and Standley 2013), exported to MEGA7 (Kumar et al. 2016) and the best-fit substitution model calculated. Phylogenetic analyses were performed

with FastTree2 v2.1.10 (Price et al. 2010) and MrBayes 3.2.6 (Ronquist et al. 2012). Bayesian posterior probability (BPP) and Maximum-Likelihood (ML) bootstrap values (above 0.50) are reported next to the node. The scale bar represents the number of expected substitutions per site. GenBank accession numbers are listed in Supplementary file 1

despite significant developments, the taxonomy of this complex remains in a state of flux. Three major clades can be recognised in the complex (the theobromicola, kahawae and gloeosporioides clades), but phylogenetic distances between

species vary strongly in each of these clades, mostly showing little geographical structure.

Members of the gloeosporioides species complex have been associated with 283 plant species belonging to 212

genera and the majority of those species (80.6%) belong to eudicots whereas only a smaller part belongs to monocots and gymnosperms (16.1% and 2.2% respectively). Members of the gloeosporioides species complex have also been reported as opportunistic pathogens of humans (Werbel et al. 2019).

Most of the species within the complex are polyphagous, but some show a strong specialisation towards one host. An example is provided by *C. kahawae* a highly aggressive and specialised pathogen of coffee, causing the devastating Coffee Berry Disease. This pathogen has the unique ability to infect green developing coffee berries and for its massive economic impact, it is ranked as a quarantine pathogen and even as a biological weapon (Australia Group 2014; Batista et al. 2017).

The gloeosporioides complex is the most common and polyphagous species complex of the genus.

Colletotrichum aenigma B. Weir and P.R. Johnst., *Stud. Mycol.* **73**: 135 (2012)

Colletotrichum aenigma was described based only on two isolates (Weir et al. 2012), but was subsequently recognised as inhabiting multiple hosts in diverse locations, namely: *Actinidia arguta* (Actinidaceae) in China (Wang et al. 2019a); *Aquilaria sinensis* (Thymelaeaceae) in China (Liu et al. 2021a); *Camellia japonica*, *C. oleifera*, *C. sasanqua* and *C. sinensis* (Theaceae) in China (Wang et al. 2016, 2020a; Chen et al. 2019a; Yang et al. 2019a); *Capsicum* sp. (Solanaceae) in China (Diao et al. 2017); *Citrus sinensis* (Rutaceae) in Italy (Schena et al. 2014); *Cyclocarya paliurus* (Juglandaceae) in China (Zheng et al. 2021b); *Fragaria* × *ananassa* (Rosaceae) in China (Han et al. 2016; Chen et al. 2020); *Hylocereus undatus* (Cactaceae) in Thailand (Meetum et al. 2015); *Juglans regia* (Juglandaceae) in China (Wang et al. 2021e); *Malus domestica* (Rosaceae) in China (Zhang et al. 2021b); *Olea europaea* (Oleaceae) in Italy (Schena et al. 2014); *Persea americana* (Lauraceae) in Israel (Weir et al. 2012; Sharma et al. 2017); *Populus* sp. (as *Colletotrichum populi*) in China (Li et al. 2012); *Pyrus bretschneideri* (Rosaceae) in China (Fu et al. 2019); *P. communis* in Italy (Mosca et al. 2014; Schena et al. 2014) and *P. pyrifolia* in China and Japan (Weir et al. 2012; Fu et al. 2019); *Sedum kamtschaticum* (Crassulaceae) in Korea (Choi et al. 2017); *Vitis vinifera* (Vitaceae) in China (Yan et al. 2015) and Korea (Kim et al. 2021). *Colletotrichum aenigma* thus seems to be a fungus in expansion, hosted by numerous agricultural crop plants (Supplementary data 9, panel A).

Colletotrichum aeshynomenes B. Weir and P.R. Johnst., *Stud. Mycol.* **73**: 135 (2012)

Besides being a pathogen of the weed *Aeschynomene indica* (Fabaceae) in the USA (Weir et al. 2012), *Colletotrichum aeshynomenes* was recently reported in Brazil as causing anthracnose in cacao (*Theobroma cacao*; Malvaceae) (Nascimento et al. 2019a) and in *Myrciaria dubia* (Myrtaceae) (Matos et al. 2020) and as an endophyte on *Vellozia gigantea* (Velloziaceae) (Ferreira et al. 2017), as well as from Thailand on *Manihot esculenta* (Euphorbiaceae) with unconfirmed pathogenicity (Sangpueak et al. 2018).

Colletotrichum alatae B. Weir and P.R. Johnst., *Stud. Mycol.* **73**: 135 (2012)

Colletotrichum alatae is recorded only from water yam (*Dioscorea alata*, Dioscoreaceae) from America, Africa and Asia (Weir et al. 2012; Lin et al. 2018b). It is a common and host-specific fungus.

Colletotrichum alienum B. Weir and P.R. Johnst., *Stud. Mycol.* **73**: 139 (2012)

Colletotrichum alienum is recorded as a pathogen from multiple dicotyledonous hosts in Oceania, Asia, Africa and Europe (Supplementary data 9, panel B), namely on: *Aquilaria sinensis* in China (Thymelaeaceae; Liu et al. 2020a); *Camellia sinensis* in China (Theaceae; Liu et al. 2015a); *Diospyros kaki* in New Zealand (Ebenaceae; Weir et al. 2012); *Fragaria* × *ananassa* in Australia (Rosaceae; Shivas et al. 2016); *Grevillea* sp. in Australia (Proteaceae; Liu et al. 2013a); *Leucadendron* sp. in Portugal and South Africa (Proteaceae; Liu et al. 2013a); *Malus domestica* in New Zealand (Rosaceae; Weir et al. 2012); *Mangifera indica* in China (Anacardiaceae; Ahmad et al. 2021); *Nerium oleander* in Australia (Apocynaceae; Schena et al. 2014); *Persea americana* in Australia, New Zealand and Israel (Lauraceae; Weir et al. 2012; Sharma et al. 2017); *Protea cynaroides* in Portugal and South Africa (Proteaceae; Liu et al. 2013a); *Serruria* sp. in South Africa (Proteaceae; Liu et al. 2013a). Additionally, it was recently recorded in Mexico as a pathogen in mango (*Mangifera indica*; Tovar-Pedraza et al. 2020) and in Uruguay associated to olive anthracnose (Moreira et al. 2021), suggesting its spread to America.

Colletotrichum aotearoa B. Weir and P.R. Johnst., *Stud. Mycol.* **73**: 139 (2012)

This species is reported from numerous native angiosperms and gymnosperms from Australia and New Zealand (Supplementary data 9, panel C) either as pathogen or as endophyte

(Weir et al. 2012; Liu et al. 2013a; Shivas et al. 2016), including: the Araliaceae *Meryta sinclairii*; the Berberidaceae *Berberis glaucocarpa*; the Lamiaceae *Vitex lucens*; the Loganiaceae *Geniostoma rupestre* var. *ligustrifolium*; the Meliaceae *Dysoxylum spectabile*; the Monimiaceae *Hedycarya angustifolia*; the Myrtaceae *Syzygium smithii* (as *Acmena smithii*) and *Kunzea ericoides*; the Oleaceae *Ligustrum lucidum*; the Podocarpaceae *Dacrycarpus dacrydioides*, *Podocarpus totara* and *Prumnopitys ferruginea*; the Proteaceae *Banksia marginata* and *Knightia* sp.; the Rubiaceae *Coprosma* sp.; the Violaceae *Meliclytus ramiflorus*. It was also found on banana in India and classified as “slightly pathogenic” (Sharma et al. 2015). The presence of *C. aotearoa* on *Boehmeria* in China needs to be confirmed (Weir et al. 2012).

Colletotrichum arecicola X.R. Cao, H.Y. Che and D.Q. Luo, *Plant Dis.* **104**: 1369 (2020)

Colletotrichum arecicola was recently described as a leaf pathogen of *Areca catechu* in China (Cao et al. 2020). Whereas there were no previous occurrences of *Colletotrichum* reported from *Areca* hosts, that study detected several species of *Colletotrichum* occurring on *Areca catechu*, suggesting that further surveys are necessary to ascertain the pathological relevance, geographic distribution and conservation status of *C. arecicola*.

Colletotrichum artocarpicola Bhunjun, Jayawardena, Jee-won and K.D. Hyde, *Phytotaxa* **418**: 273 (2019)

Colletotrichum artocarpicola was collected as a saprobe from a dead root of jackfruit (*Artocarpus heterophyllus*, Moraceae) in Thailand in 2018 (Bhunjun et al. 2019). The pathological and conservation status of this fungus remains to be investigated. The host plant is a widely cultivated tropical fruit tree.

Colletotrichum asianum Prihastuti, L. Cai and K.D. Hyde, *Fungal Divers.* **39**: 96 (2009)

Colletotrichum asianum is isolated recurrently and with high frequency as a pathogen of mango (*Mangifera indica*) from different parts of the world (Supplementary data 9, panel D), typically along with *C. siamense* and several other species (Li et al. 2019a,b; Tovar-Pedraza et al. 2020; Benatar et al. 2021). It was also recently reported from avocado (*Persea americana*) in Indonesia (Zhafarina et al. 2021).

Colletotrichum australianum W. Wang, D. D. De Silva, and P. W. J. Taylor, *J. Fungi* **7**:47 (2021)

The species *Colletotrichum australianum* was recently described to accommodate fungi found in association with citrus anthracnose in Australia, namely on *Citrus reticulata* and *C. sinensis* (Wang et al. 2021c). The species also encompasses a fungus previously identified as *Colletotrichum queenslandicum*, isolated from chilli (*Capsicum annuum*). The pathological relevance and host range of *C. australianum* remains to be established, but this fungus may become of quarantine relevance.

Colletotrichum camelliae Masee, *Bull. Misc. Inf., Kew*: 91 (1899)

Colletotrichum camelliae is known only from *Camellia* spp. (Wang et al. 2016, 2020a; Lu et al. 2018; Win et al. 2018; He et al. 2019). Besides one isolate collected in the USA in 1982 (Liu et al. 2015a), the pathogen seems to be more frequent in Asia (Supplementary data 9, panel E).

Colletotrichum changpingense G. Zhang, Jayawardena and K.D. Hyde, *Mycosphere* **7**: 1155 (2016)

There are two records for *Colletotrichum changpingense*, obtained from diseased strawberry (*Fragaria × ananassa*) rhizomes in China in 2011 and 2012 (Jayawardena et al. 2016b). There are multiple *Colletotrichum* species associated with strawberry plants and the pathological relevance and the ecological status of *C. changpingense* require clarification.

Colletotrichum Chiangmaiense N.I. de Silva, Lumyong & K.D. Hyde, *Mycosphere* **12**(1): 192 (2021)

Colletotrichum Chiangmaiense is known from a single isolate collected as an endophyte in leaves of *Magnolia garrettii* (Magnoliaceae) in 2017 in Thailand (De Silva et al. 2021a, b). There are no further records of this fungus and other species of *Colletotrichum* are known from other *Magnolia* spp., rendering the conservation status of this taxon of concern.

Colletotrichum chrysophilum W.A.S. Vieira, W.G. Lima, M.P.S. Câmara and V.P. Doyle, *Mycologia* **109**: 912 (2017)

The taxon *Colletotrichum chrysophilum* was recently described based on fungi causing anthracnose on banana plants (*Musa acuminata*) in Brazil, but also containing

fungi previously assigned to *C. ignotum* E.I. Rojas, S.A. Rehner and Samuels, which includes endophytes of *Theobroma cacao* (Malvaceae), *Genipa americana* (Rubiaceae), *Tetragastris panamensis* (Burseraceae) and *Terpsichore taxifolia* (Polypodiaceae) from Panama and Puerto Rico (Vieira et al. 2017). The fungus was also found in Brazil as a causal agent both of cashew (*Anacardium* spp.) anthracnose (Veloso et al. 2018) and of cassava (*Manihot esculenta*) anthracnose (Machado et al. 2021a), and was also associated to banana and avocado anthracnose in Mexico (Fuentes-Aragón et al. 2020, 2021). The importance of this taxon as an avocado, banana, cassava or cashew pathogen requires further investigation. Being currently restricted to the American continent, it may become a quarantine pathogen for these crops in other continents.

Colletotrichum cigarro (B.S. Weir and P.R. Johnston) A. Cabral and P. Talhinhos, *Plants* **9**: 502 (2020)

Colletotrichum cigarro, recently named by raising *C. kahawae* ssp. *cigarro* to the species rank (Cabral et al. 2020), is known from numerous hosts and regions, including the Proteaceae *Banksia* sp. and *Dryandra* sp. in Portugal (Madeira) and Spain (Weir et al. 2012; Liu et al. 2013a), *Leucospermum* sp. in the USA (Hawaii) (Weir et al. 2012) and *Toronia toru* in New Zealand (Weir et al. 2012), the Rosaceae *Dryas octopetala* in Switzerland (Weir et al. 2012), apple (*Malus domestica*) in Belgium and the USA (Grammen et al. 2019; McCulloch et al. 2020) and *Rubus glaucus* in Colombia (Afanador-Kafuri et al. 2014), the Myrtaceae *Eucalyptus grandis* in South Africa (Mangwende et al. 2020) and *Kunzea ericoides* in New Zealand (Weir et al. 2012), as well as on *Areca catechu* (Arecaceae) in China (Zhang et al. 2020d), *Citrus reticulata* (Rutaceae) in Italy (Perrone et al. 2016), *Eruca vesicaria* (as *E. sativa*, Brassicaceae) in Italy (Garibaldi et al. 2016a), *Hypericum perforatum* (Hypericaceae) in Germany (Weir et al. 2012), *Liquidambar styraciflua* (Altingiaceae) in Italy (Garibaldi et al. 2016b; Guarnaccia et al. 2021), mango (*Mangifera indica*, Anacardiaceae) in Colombia and Italy (Ismail et al. 2015; Pardo-De La Hoz et al. 2016), *Miconia* sp. (Melastomataceae) in Brazil (Weir et al. 2012), *Morus alba* (Moraceae) in China (Xue et al. 2019), olive (*Olea europaea*, Oleaceae) in Australia and Italy (Weir et al. 2012; Schena et al. 2014), avocado (*Persea americana*, Lauraceae) in Korea and New Zealand (Weir et al. 2012; Kwon et al. 2020), tree tomato (*Solanum betaceum*, Solanaceae) in Colombia (Rojas et al. 2018) and *Vaccinium macrocarpum* (Ericaceae) in the USA (Weir et al. 2012). *Colletotrichum cigarro* is thus a common fungus worldwide (Supplementary data 9, panel F).

Colletotrichum clidemiae B.S. Weir and P.R. Johnst., *Stud. Mycol.* **73**: 148 (2012)

Colletotrichum clidemiae is known from the USA and Panama on *Clidemia hirta* (Melastomataceae), and from the USA on *Vitis* sp. and *Quercus* sp. (Weir et al. 2012). No additional isolates have been reported since the taxon was described, indicating that the conservation status of *C. clidemiae* requires clarification.

Colletotrichum cobbittiense S. Luo, G. Dong and P. Wong, *Persoonia* **40**: 240 (2018)

Colletotrichum cobbittiense includes a single isolate collected from leaf lesions of *Cordyline stricta* × *C. australis* (Asparagaceae) in Australia in 2016 (Crous et al. 2018c). There are several species of *Colletotrichum* occurring on *Cordyline*, rendering the pathological status of *C. cobbittiense* uncertain and its conservation status of concern.

Colletotrichum conoides Y.Z. Diao, C. Zhang, L. Cai and X.L. Liu, *Persoonia* **38**: 27 (2017)

The species *Colletotrichum conoides* was designated based on an isolate collected from *Capsicum annuum* var. *conoides* fruits in China in 2010 (Diao et al. 2017). The fungus was subsequently found associated with anthracnose symptoms on *Pyrus pyrifolia* in China in 2015 (Fu et al. 2019). Both hosts harbour numerous species of *Colletotrichum*, rendering the pathological status of *C. conoides* uncertain and its conservation status of concern.

Colletotrichum cordylinicola Phoulivong, L. Cai and K. D. Hyde, *Mycotaxon* **114**: 251 (2011)

Colletotrichum cordylinicola is known from *Cordyline* spp. (Asparagaceae) in the USA (Sharma et al. 2014) and Thailand, from *Eugenia* sp. (Myrtaceae) in Laos and from *Areca catechu* (Arecaceae) in China (Cao et al. 2020). Additional species of *Colletotrichum* are reported from these hosts, rendering the pathological status of *C. cordylinicola* uncertain and its conservation status of concern.

Colletotrichum cycadis Andjic, Maxwell & Smith, *Persoonia* **45**:251-409 (2020)

The species *Colletotrichum cycadis* was described based on fungi isolated from leaf spots on *Cycas revoluta* (Cycadaceae) plants originary from China (Crous et al. 2020). Records of *Colletotrichum* spp. on *Cycas* are seldom, but given the ornamental importance of these plants, the pathological relevance of this fungus needs to be studied.

Colletotrichum dracaenigenum Chaiwan & K.D. Hyde, *Phytotaxa* **491**:143–157 (2021)

Colletotrichum dracaenigenum was described based on a single isolate obtained in 2017 in Thailand on dead leaves of *Dracaena fragrans* (Asparagaceae) and assumed as a saprobe (Chaiwan et al. 2021). Given that there are several species of *Colletotrichum* on *Dracaena* spp., the conservation status of *C. dracaenigenum* is uncertain and of concern.

Colletotrichum endophyticum Manamgoda, Udayanga, L. Cai and K.D. Hyde, *Fungal Divers.* **61**: 110 (2013)

Colletotrichum endophyticum was reported as an endophyte collected in Thailand in 2010 on *Pennisetum purpureum* (Poaceae) and on an unknown wild fruit (Manamgoda et al. 2013), and subsequently found as an endophyte on *Capsicum annuum* fruits in Thailand and in China (Diao et al. 2017; De Silva et al. 2019). Nevertheless, *C. endophyticum* was found as an anthracnose pathogen associated to *Camellia sinensis* leaves (Wang et al. 2016), to coffee (*Coffea arabica* and *C. robusta*) leaves and fruits (Cao et al. 2019a) and to mango leaves and fruits (Li et al. 2019b) in China. *Colletotrichum endophyticum* could be emerging in Southeast Asia and may be of pathological concern to the host crops (tea, coffee and mango) in which it was shown to be pathogenic. However, any of these three crops harbour a vast array of *Colletotrichum* species, suggesting attentive surveys for the presence and spread of *C. endophyticum*.

Colletotrichum fructicola Prihastuti, L. Cai and K.D. Hyde, *Fungal Divers.* **39**: 96 (2009)

Colletotrichum fructicola is a cosmopolitan fungus, found in all continents and in a wide range of host plants (Supplementary data 9, panel G), but mostly occurring in tropical and sub-tropical regions. *Colletotrichum fructicola* typically occurs along other *Colletotrichum* species associated to anthracnose symptoms, often being a less frequent and/or less virulent population. However, several reports consistently place *C. fructicola* as the most frequently isolated fungus associated with apple bitter rot in South America (Alaniz et al. 2019; Moreira et al. 2019a; Velho et al. 2019), in contrast with *C. fioriniae* as the main causal agent of this disease in North America and Europe. Other reports where *C. fructicola* was recorded as the main anthracnose pathogen are on *Annona* spp. in Brazil (Costa et al. 2019) and on *Pyrus* spp. (Fu et al. 2019), strawberry (Jayawardena et al. 2016b), tea plant (*Camellia sinensis*; Wang et al. 2016) and tea-oil tree (*Camellia oleifera*; Wang et al. 2020a) in China.

Colletotrichum fructivorum V.P. Doyle, P.V. Oudem. and S.A. Rehner, *PLoS ONE* **7**: e51392 (2012)

Colletotrichum fructivorum includes isolates obtained in the USA from fruits of cultivated *Vaccinium macrocarpon* and wild *V. oxycoccos* (Ericaceae) and stems of *Rhexia virginica* (Melastomataceae) in 2009–2010 (Doyle et al. 2013) (Supplementary data 9, panel H). However, no further occurrences of *C. fructivorum* have been reported ever since, raising concern on its conservation status.

Colletotrichum gloeosporioides (Penz.) Penz. and Sacc., *Atti Inst. Veneto Sci. Lett., ed Arti, Sér.* **6** (2): 670 (1884)

For over 100 years the limits of the taxon *Colletotrichum gloeosporioides* have changed several times. Following Cannon et al. (2008) and Weir et al. (2012), modern *C. gloeosporioides*, or *C. gloeosporioides* sensu stricto, was defined based on fungi occurring on *Citrus* spp., as well as on hosts such as *Ficus*, *Mangifera*, *Pueraria* and *Vitis*, suggesting that this taxon was not of cosmopolitan distribution (Phoulivong et al. 2010). However, in the last decade, *C. gloeosporioides* sensu stricto was recorded in a vast number of hosts and locations in addition to those hosts: okra (*Abelmoschus esculentus*, Malvaceae) in China (Shi et al. 2019); *Acca sellowiana* (Myrtaceae) in Brazil (Fantinel et al. 2017); *Acer coriaceifolium* (Sapindaceae) in China (Zhu et al. 2020); *Actinidia* spp. (Actinidiaceae) in China (Deng et al. 2017; Li et al. 2017a); *Akebia trifoliata* (Lardizabalaceae) in China (Pan et al. 2021); *Annona* spp. (Annonaceae) in Brazil (Costa et al. 2019), Colombia (Álvarez et al. 2014) and Italy (Schena et al. 2014); *Anoectochilus roxburghii* (Orchidaceae) in China (Chen et al. 2016b); *Areca catechu* (Arecaceae) in China (Cao et al. 2020); *Atalantia citroides* (Rutaceae) in Spain (Guarnaccia et al. 2017); *Barringtonia edulis* (Lecythidaceae) in Papua New Guinea (Buyoyu et al. 2017); *Bauhinia blakeana* (Fabaceae) in China (Li et al. 2016a); *Camellia oleifera* and *C. sinensis* (Theaceae) in China (Guo et al. 2014a; Wang et al. 2020a); chilli (*Capsicum* spp., Solanaceae) in China (Diao et al. 2017; Li et al. 2021); *Catalpa fargesii* f. *duciouxii* (Bignoniaceae) in China (Fu et al. 2013); *Chaenomeles sinensis* (Rosaceae) in China (Ni et al. 2021); *Choerospondias axillaris* (Anacardiaceae) in China (Li et al. 2017b); Arabica coffee (*Coffea arabica*, Rubiaceae) in Mexico (Cristóbal-Martínez et al. 2017); *Crataegus gracilior* (Rosaceae) in Mexico (Nieto-López et al. 2018); *Cunninghamia lanceolata* (Cupressaceae) in China (Huang et al. 2019); *Cyclocarya paliurus* (Juglandaceae) in China (Zheng et al. 2021b); *Dendrobium officinale* (Orchidaceae) in China (Lan et al. 2016); *Elaeocarpus sylvestris* (Elaeocarpaceae) in China (Li et al. 2016b);

Elettaria cardamomum (Zingiberaceae) in India (Chethana et al. 2016); loquat (*Eriobotrya japonica*, Rosaceae) in Pakistan (Naz et al. 2017); *Euonymus japonicus* (Celastraceae) in China (Huang et al. 2016); *Falcataria moluccana* (as *Albizia falcataria*, Fabaceae) in China (Chen et al. 2019b); *Hymenocallis littoralis* (Amaryllidaceae) in China (Zhao et al. 2019); walnut (*Juglans regia*, Juglandaceae) in China (Wang et al. 2020b; Yang et al. 2021); *Ligustrum japonicum* (Oleaceae) in China (Shen et al. 2017); *Liriodendron chinense* × *tulipifera* (Magnoliaceae) in China (Zhu et al. 2019a); *Liriope cymbidiomorpha* (Asparagaceae) in China (Yang et al. 2020); *Magnolia candolli* (Magnoliaceae) in China (De Silva et al. 2021a, b); *Malus pumila* (Rosaceae) in Korea (Cheon et al. 2016); *Mikania micrantha* (Asteraceae) in China (Zhu et al. 2019b); banana (*Musa acuminata*, Musaceae) in Ecuador, Malaysia and Pakistan (Intan Sakinah et al. 2013; Riera et al. 2019; Alam et al. 2021); olive (*Olea europaea*, Oleaceae) in Italy, Portugal and Tunisia (Mosca et al. 2014; Chattaoui et al. 2016; Talhinas et al. 2018); *Osmanthus fragrans* (Oleaceae) in China (Tang et al. 2018); *Oxalis corniculata* (Oxalidaceae) in Brazil (Bellé et al. 2019); *Paeonia lactiflora* (Paeoniaceae) in China (Zhang and Dai 2017); avocado (*Persea americana*, Lauraceae) in Israel and Turkey (Akgül et al. 2016; Sharma et al. 2017); *Pouteria caimito* (Sapotaceae) in China (Duan et al. 2018b); *Pteridium aquilinum* (Dennstaedtiaceae) in China (Tan et al. 2017); pomegranate (*Punica granatum*, Lythraceae) in the USA (Xavier et al. 2019); *Pyrus* spp. (Rosaceae) in China (Fu et al. 2019); *Quercus glauca* (Fagaceae) in China (Liu et al. 2021c); *Robinia pseudoacacia* (Fabaceae) in China (Xue et al. 2018a); rose (*Rosa* sp., Rosaceae) in South Korea (Hassan et al. 2019b); *Rubia cordifolia* (Rubiaceae) in China (Tang and Tan 2020); *Sedum kamtschaticum* (Crassulaceae) in South Korea (Jeon and Kwak 2016); *Smilax sieboldii* (Smilacaceae) in China (Zhang et al. 2017); *Sorbaria sorbifolia* (Rosaceae) in China (Li et al. 2019c; Wang et al. 2021a); *Syzygium samarangense* (Myrtaceae) in Malaysia (Al-Obaidi et al. 2017); *Viburnum odoratissimum* (Adoxaceae) in China (Yang et al. 2015). *Colletotrichum gloeosporioides* sensu stricto is thus a cosmopolitan fungus (Supplementary data 9, panel I), inhabiting a wide range of host plants.

Colletotrichum grevilleae F. Liu, Damm, L. Cai and Crous, *Fungal Divers.* **61**: 98 (2013)

Colletotrichum grevilleae is known only from a single isolate collected from root and collar rot of *Grevillea* sp. (Proteaceae) in Italy in 2000 (Liu et al. 2013a). No further occurrences of *C. grevilleae* have been reported ever since and several other species of *Colletotrichum* occur on *Grevillea*, raising great concern on its conservation status.

Colletotrichum grossum Y.Z. Diao, C. Zhang, L. Cai and X.L. Liu, *Persoonia* **38**: 29 (2017)

The species *Colletotrichum grossum* was recently defined based on one isolate collected from *Capsicum annuum* var. *grossum* in China in 2011 (Diao et al. 2017). The fungus was recently identified on chilli in Italy (Guarnaccia et al. 2021). The scarcity of reports of *C. grossum* and the occurrence of several other species of *Colletotrichum* on chilli raise concern on the conservation status of this species.

Colletotrichum hebeiense X.H. Li, Y. Wang, K.D. Hyde, M.M.R.S. Jayawardena and J.Y. Yan, *Fungal Divers.* **71**: 241 (2015)

Colletotrichum hebeiense is defined based on two isolates obtained from grapes (*Vitis vinifera*) in two locations in China in 2009 (Yan et al. 2015). No additional occurrences of *C. hebeiense* have been recorded ever since. Considering that a vast list of species of *Colletotrichum* is known from *Vitis* spp., the conservation status of *C. hebeiense* is of serious concern.

Colletotrichum hedericola Jayaward., Camporesi and K.D. Hyde, *Fungal Divers.* **100**: 5 (2020)

The species *Colletotrichum hedericola* was recently coined to accommodate a fungus isolated as a saprobe from a dead branch of ivy (*Hedera helix*, Araliaceae) in Italy in 2014 (Hyde et al. 2020a). No further records of *C. hedericola* are known. *Colletotrichum trichellum*, also reported from *Hedera* spp., is also seldom. The conservation status of *C. hedericola* is therefore of great concern.

Colletotrichum helleniense Guarnaccia and Crous, *Persoonia* **39**: 32 (2017)

Colletotrichum helleniense is a taxon containing isolates associated with citrus anthracnose, namely from wither-tip twigs of *Citrus reticulata* and *C. trifoliata* (as *Poncirus trifoliata*, Rutaceae) from the same location in Greece in 2015 (Guarnaccia et al. 2017). No additional occurrences of *C. helleniense* have been recorded ever since and numerous species of *Colletotrichum* occur on citrus, rendering the conservation status of *C. helleniense* of concern.

Colletotrichum henanense F. Liu and L. Cai, *Persoonia* **35**: 80 (2015)

Colletotrichum henanense was described based on two isolates obtained in China from tea (*Camellia sinensis*, Theaceae) in 2012 and from *Cirsium japonicum*

(Asteraceae) in 2010 (Liu et al. 2015a). Subsequently the fungus was detected also in China, causing anthracnose on *Camellia oleifera* in 2016 (Li et al. 2018c). This is the single report of *Colletotrichum* on *Cirsium*, suggesting that this is not a common host of *Colletotrichum* spp. On the other hand, there are many species of *Colletotrichum* reported on *Camellia* spp., raising concerns on the conservation status of *Colletotrichum henanense*.

Colletotrichum horii B. Weir and P.R. Johnst., *Mycotaxon* **111**: 211 (2010)

Colletotrichum horii is defined based on fungal pathogens of persimmon (*Diospyros kaki*, Ebenaceae) from China, Korea, Japan and New Zealand (Weir and Johnston 2010). The fungus has subsequently been reported from Brazil associated to twig blight and defoliation (Mio et al. 2015), with further reports from Korea showing severe infections (Kwon et al. 2013; Jeon et al. 2017; An et al. 2018). *Colletotrichum horii* is apparently specific to persimmon, occurring commonly in Asia (Supplementary data 9, panel J) and may be considered a quarantine pathogen elsewhere.

Colletotrichum hystricis Guarnaccia and Crous, *Persoonia* **39**: 32 (2017)

The species *Colletotrichum hystricis* includes a single isolate obtained from a leaf lesion of *Citrus hystrix* (Rutaceae) in Italy in 2016 (Guarnaccia et al. 2017). The occurrence of multiple species of *Colletotrichum* on citrus renders the conservation status of *C. hystricis* of serious concern.

Colletotrichum jiangxiense F. Liu and L. Cai, *Persoonia* **35**: 82 (2015)

The species *Colletotrichum jiangxiense* was designated based on two isolates collected from tea plant (*Camellia sinensis*, Theaceae) in China in 2013 (Liu et al. 2015a). The species was subsequently identified as an endophyte on *Dendrobium* sp. (Orchidaceae) in Thailand (Ma et al. 2018) and associated to avocado (*Persea americana*, Lauraceae) anthracnose in Mexico (Ayvar-Serna et al. 2021). The uncertainty about its pathological status and the occurrence of vast numbers of species of *Colletotrichum* on its hosts raise concern about the conservation status of *C. jiangxiense*.

Colletotrichum kahawae J.M Waller and Bridge, *Mycol. Res.* **97**(8): 993 (1993)

Colletotrichum kahawae is found in Africa in *Coffea* spp. (Rubiaceae), causing the Coffee Berry Disease (Waller et al.

1993; Cabral et al. 2020). This fungus has undergone a host-jump speciation process (Silva et al. 2012a) accompanied by a genome size expansion (Pires et al. 2016), becoming biologically and phylogenetically isolated from the closely related *Colletotrichum cigarro* (Cabral et al. 2020). Although common in Africa (Supplementary data 9, panel K), this pathogen is of quarantine concern in coffee growing regions in Asia and America (Batista et al. 2017).

Colletotrichum makassarensense D.D. De Silva, P.W. Crous and P.W.J. Taylor, *IMA Fungus* **10**: 8 (2019)

The taxon *Colletotrichum makassarensense* was designated to accommodate a single isolate obtained from chilli (*Cap-sicum annum*, Solanaceae) in Indonesia (De Silva et al. 2019). No further isolates of *Colletotrichum makassarensense* have been reported and many other species of *Colletotrichum* are known from chilli, raising high concern about the conservation status of this species.

Colletotrichum musae (Berk. and M. A. Curtis) Arx and Verh. *K. ned. Akad. Wet.*, tweede sect. 51(3): 107 (1957)

Colletotrichum musae is the causal agent of banana (*Musa* sp., Musaceae) anthracnose, occurring worldwide (Supplementary data 9, panel L) as a common post-harvest disease (Weir et al. 2012).

Colletotrichum nupharicola D.A. Johnson, Carris and J.D. Rogers, *Mycol. Res.* **101**: 647 (1997)

The species *Colletotrichum nupharicola* was described based on isolates collected from the water lilies *Nuphar lutea* and *Nymphaea odorata* (Nymphaeaceae) in the USA in the 1990s (Weir et al. 2012). No further occurrences of *C. nupharicola* have been recorded thereafter, but this taxon has been reported recently from avocado (*Persea americana*, Lauraceae) in Israel (Sharma et al. 2017). The geographic distribution, pathological relevance and conservation status of *C. nupharicola* are thus unknown and require further investigation.

Colletotrichum pandanicola Tibpromma and K.D. Hyde, *MycKeys* **33**: 25 (2018)

This species is recorded only from an epiphytic fungus occurring on leaves on an unspecified species of *Pandanus* (Pandanaceae) in Thailand in 2016 (Tibpromma et al. 2018). There are no additional reports of this fungus and other species of *Colletotrichum* occur on *Pandanus*, raising serious concerns on the conservation status of *C. pandanicola*.

Colletotrichum perseae G. Sharma and S. Freeman, *Sci. Rep.* **17**: 15839 (2017)

Colletotrichum perseae was reported from several locations in Israel in 2014, among several other species of *Colletotrichum*, as the prevailing pathogen associated to leaf spots and fruit rot of avocado (*Persea americana*, Lauraceae) (Sharma et al. 2017). The fungus was recently detected in New Zealand, also associated to mango anthracnose (Hofer et al. 2021). The pathological relevance of *C. perseae* to avocado cultivation remains to be analysed, suggesting that it may be considered a quarantine pathogen.

Colletotrichum proteae F. Liu, Damm, L. Cai and Crous, *Fungal Divers.* **61**: 100 (2013)

Colletotrichum proteae is known from a single isolate, collected from an unspecified species of *Protea* (Proteaceae) in South Africa in 2008 (Liu et al. 2013a). Its pathological condition is not known and there are several other species of *Colletotrichum* occurring on *Protea* and on Proteaceae, which raises severe concerns about the conservation status of *C. proteae*.

Colletotrichum pseudotheobromicola Chethana, Yan, Li and K.D. Hyde, *Mycosphere* **10**: 518 (2019)

Colletotrichum pseudotheobromicola has been recently named to accommodate a fungus associated to leaf spots of *Prunus avium* (Rosaceae) in China (Chethana et al. 2019). This is the single report of this species and there are numerous species of *Colletotrichum* occurring on *Prunus* (and even specifically on *P. avium*), suggesting that the pathological relevance and the conservation status of *C. pseudotheobromicola* require further investigation.

Colletotrichum psidii Curzi, *Atti Ist. bot. R. Univ. Pavia*, 3 Sér. **3**: 207 (1927)

Colletotrichum psidii is known from a single occurrence, collected from guava (*Psidium* sp., Myrtaceae) in Italy, prior to 1927 (Weir et al. 2012). The only available culture in collection is reported as sterile (Weir et al. 2012). The absence of any further records of this species, along with the occurrence of several other species of *Colletotrichum* on guava, suggests that *Colletotrichum psidii* may be extinct.

Colletotrichum queenslandicum B. Weir and P.R. Johnst., *Stud. Mycol.* **73**: 164 (2012)

Colletotrichum queenslandicum was originally described from papaya (*Carica papaya*, Caricaceae) and avocado (*Persea americana*, Lauraceae) in Australia and from cashew

(*Anacardium occidentale*, Anacardiaceae) in Brazil (Veloso et al. 2018) and coffee (*Coffea* sp., Rubiaceae) in Fiji (Weir et al. 2012). It was subsequently reported from persian lime (*Citrus × latifolia*, Rutaceae) in the USA (Kunta et al. 2018), from *Licania tomentosa* (Chrysobalanaceae) in Brazil (Lisboa et al. 2018), from lychee (*Litchi chinensis*, Sapindaceae) in Australia (Anderson et al. 2013; Shivas et al. 2016), from mango (*Mangifera indica*, Anacardiaceae) in Australia (Shivas et al. 2016), from *Nephelium lappaceum* (Sapindaceae) in Puerto Rico (Serrato-Diaz et al. 2017), from olive (*Olea europaea*, Oleaceae) in Montenegro (Scheda et al. 2014) and from passionfruit (*Passiflora edulis*, Passifloraceae) in Australia (Shivas et al. 2016). Such recent reports of *C. queenslandicum*, besides confirming this as a common fungus in Australia, revealed its presence in America and Europe (Supplementary data 9, panel M), associated to woody agricultural crops. The pathological relevance and the host range of *C. queenslandicum* should be analysed, namely in a quarantine perspective.

Colletotrichum rhexiae Ellis and Everh., *Proc. Acad. nat. Sci. Philad.* **46**: 372 (1894)

Colletotrichum rhexiae is known from *Rhexia virginica* (Melastomataceae) leaf and stem lesions and from *Vaccinium macrocarpon* (Ericaceae) fruit lesions in the USA (Doyle et al. 2013). No additional reports of this species have occurred, suggesting that it is geographically confined and that it may not occur on major agricultural crops. Further surveys would improve current knowledge on the conservation status of *C. rhexiae*.

Colletotrichum salsolae B. Weir and P.R. Johnst., *Stud. Mycol.* **73**: 164 (2012)

Colletotrichum salsolae is known from *Salsola kali* subsp. *tragus* (Amaranthaceae), occurring throughout the geographic range of the host (Weir et al. 2012). Recently, the fungus was reported as a causal agent of anthracnose on papaya (*Carica papaya*, Caricaceae) fruits in India, along with *Colletotrichum gloeosporioides* (Saini et al. 2017a).

Colletotrichum siamense Phoulivong, L. Cai and K.D. Hyde, *Fungal Divers.* **39**: 98 (2009)

Liu et al. (2016c) synonymised several species (namely *Colletotrichum communis*, *C. dianesei*, *C. endomangiferae*, *C. hymenocallidis*, *C. jasmimi-sambac* and *C. murrayae*) to *C. siamense*, thus recognising its occurrence on multiple hosts, to which add additional recent reports. *Colletotrichum siamense* is thus known from *Alocasia macrorrhizos* (Araceae), *Alpinia purpurata* (Zingiberaceae),

Amorphophallus paeoniifolius (Araceae), *Anacardium occidentale*, *A. humile* and *A. othonianum* (Anacardiaceae), *Annona muricata* (Annonaceae), *Areca catechu* (Arecaceae), *Artocarpus heterophyllus* and *A. sericicarpus* (Moraceae), *Azadirachta indica* (Meliaceae), *Bauhinia forficata* and *B. variegata* (Fabaceae), *Camellia chrysantha*, *C. oleifera* and *C. sinensis* (Theaceae), *Capsicum annuum*, *C. chinensis* and *C. frutescens* (Solanaceae), *Carica papaya* (Caricaceae), *Carya illinoensis* (Juglandaceae), *Cassia fistula* (Fabaceae), *Cercis chinensis* (Fabaceae), *Cinnamomum kotoense* (Lauraceae), *Citrus limon*, *C. pennivesiculata*, *C. reticulata* and *C. sinensis* (Rutaceae), *Cocos nucifera* (Areceae), *Coffea arabica* and *C. canephora* (Rubiaceae), *Commelina* sp. (Commelinaceae), *Corchorus capsularis* (Malvaceae), *Cornus hongkongensis* (Cornaceae), *Cycas debaoensis* (Cycadaceae), *Cymbopogon citratus* (Poaceae), *Datura metel* (Solanaceae), *Dieffenbachia* sp. (Araceae), *Dionaea muscipula* (Droseraceae), *Dioscorea cayennensis* ssp. *rotundata* (Dioscoreaceae), *Diospyros kaki* (Ebenaceae), *Dypsis lutescens* (as *Chrysalidocarpus lutescens*, Areceae), *Elettaria cardamomum* (Zingiberaceae), *Ensete superbum* (Musaceae), *Eriobotrya japonica* (Rosaceae), *Euonymus japonicus* (Celastraceae), *Ficus carica* and *F. elastica* (Moraceae), *Fragaria × ananassa* (Rosaceae), *Hevea brasiliensis* (Euphorbiaceae), *Hibiscus* sp. (Malvaceae), *Hylocereus lemairei* (as *Hylocereus polyrhizus*) and *H. undulatus* (Cactaceae), *Hymenocallis littoralis* (as *Hymenocallis americana*, Amaryllidaceae), *Iris tectorum* (Iridaceae), *Jasminum mesnyi* and *J. sambac* (Oleaceae), *Juglans regia* (Juglandaceae), *Licania tomentosa* (Chrysobalanaceae), *Liriodendron chinense × tulipifera* (Magnoliaceae), *Litchi chinensis* (Sapindaceae), *Macadamia integrifolia* (Proteaceae), *Machilus ichangensis* (Lauraceae), *Malus domestica* (Rosaceae), *Mandevilla* sp. (Apocynaceae), *Mangifera indica* (Anacardiaceae), *Manihot esculenta* (Euphorbiaceae), *Mentha* sp. (Lamiaceae), *Michelia alba* (Magnoliaceae), *Musa acuminata* (Musaceae), *Nelumbo nucifera* (Nelumbonaceae), *Nopalea cochenillifera* (Cactaceae), *Ocimum basilicum* (Lamiaceae), *Olea europaea* (Oleaceae), *Parthenocissus tricuspidata* (Vitaceae), *Pennisetum purpureum* (Poaceae), *Persea americana* (Lauraceae), *Piper nigrum* (Piperaceae), *Pistachia vera* (Anacardiaceae), *Plukenetia volubilis* (Euphorbiaceae), *Plumeria alba* (Apocynaceae), *Pongamia pinnata* (Fabaceae), *Protea cynaroides* (Proteaceae), *Prunus persica* (Rosaceae), *Psidium guajava* (Myrtaceae), *Punica granatum* (Lythraceae), *Pyrus communis* and *P. pyrifolia* (Rosaceae), *Rosa chinensis* (Rosaceae), *Rosmarinus officinalis* (Lamiaceae), *Salix matsudana* (Salicaceae), *Saraca indica* (Fabaceae), *Sarcandra glabra* (Chloranthaceae), *Sophora tonkinensis* (Fabaceae), *Sterculia nobilis* and *S. lanceolata* (Malvaceae), *Theobroma cacao* (Malvaceae), *Uraria picta* (Fabaceae), *Vaccinium macrocarpon* (Ericaceae), *Viola odorata* (Violaceae) and *Vitis vinifera* (Vitaceae)

(Weir et al. 2012; Cheng et al. 2013, 2019; Doyle et al. 2013; Liu et al. 2013a, 2017a; Manamgoda et al. 2013; Udayanga et al. 2013; Álvarez et al. 2014; Schena et al. 2014; Larran et al. 2015; Meetum et al. 2015; Sharma et al. 2015; Dwarka et al. 2016; Niu et al. 2016a; Shivas et al. 2016; Watanabe et al. 2016; Ye et al. 2016; Zhou et al. 2016; Conforto et al. 2017; Douanla-Meli and Unger 2017; Katoch et al. 2017; Kumar et al. 2017; Ni et al. 2017; Prasad et al. 2017; Vieira et al. 2017; Wang et al. 2017, 2020c, 2021c, 2021d; Chang et al. 2018b; Naik et al. 2018; Oliveira et al. 2018; Veloso et al. 2018; Xavier et al. 2018, 2019; Zhao et al. 2018, 2020, 2021a; Abirami et al. 2019; Cao et al. 2019b; Chaves et al. 2019; Chou et al. 2019; Feng et al. 2019; Fu et al. 2019; Ji et al. 2019; Zhang 2019b, 2020a, 2020b, 2021a, 2021d; Zhu et al. 2019a; Chen et al. 2020; Prasannath et al. 2020; Wu 2020; Borges et al. 2021; Carbone et al. 2021; Eaton et al. 2021; Han et al. 2021; Hofer et al. 2021; Huang et al. 2021a,b; Ismail et al. 2021a,b; Oh et al. 2021; Oo et al. 2021; Qin et al. 2021; Rodríguez-Palafox et al. 2021; Song et al. 2021; Zhafarina et al. 2021). *Colletotrichum siamense* is a fungus with a very broad host range and found throughout the world (Supplementary data 9, panel N), although prevailing in Australasia and tropical America, whereas it seems to be quite rare in Europe.

Colletotrichum syzygiicola Udayanga, Manamgoda and K.D. Hyde, *Fungal Divers.* **61**: 173 (2013)

Colletotrichum syzygiicola was first described from anthracnose symptoms on *Citrus aurantifolia* (Rutaceae) and *Syzygium samarangense* (Myrtaceae) fruits collected in Thailand in 2010 (Udayanga et al. 2013). The fungus was subsequently associated to anthracnose of *Elettaria cardamomum* (Zingiberaceae) in India (Chethana et al. 2016). Records of *Colletotrichum syzygiicola* are still seldom and each of the hosts is known to harbour other species of *Colletotrichum*, raising concern on the actual occurrence of this fungus in nature.

Colletotrichum tainanense D.D. De Silva, P.W. Crous and P.W.J. Taylor, *IMA Fungus* **10**: 8 (2019)

Colletotrichum tainanense is known from a single report obtained from fruits of *Capsicum annuum* (Solanaceae) in China in 2014 (De Silva et al. 2019). There are no additional reports for this taxon and multiple species of *Colletotrichum* occur on this host, raising severe concerns about the conservation status of *C. tainanense*.

Colletotrichum temperatum V. Doyle, P.V. Oudem. and S.A. Rehner, *PLoS One* **7**: e51392 (2012)

Colletotrichum temperatum is known from two isolates collected from fruit rot and asymptomatic stems of *Vaccinium*

macrocarpon (Ericaceae) in the USA in 2009 (Doyle et al. 2013). There are no further reports of this species and there are numerous other species of *Colletotrichum* recorded on *Vaccinium*, raising serious concerns about the conservation status of *C. temperatum*.

Colletotrichum theobromicola Delacr., *Bull. Soc. Mycol. Fr.* 21: 191 (1905)

Colletotrichum theobromicola, as defined by Weir et al. (2012) following Rojas et al. (2010) description, is a fungus with a broad host range, upon the placement of *C. fragariae* and *Colletotrichum gloeosporioides* f. *stylosanthis* in synonymy to it. Thereafter, the fungus has been found on other hosts, being currently known from: *Acca sellowiana* (Myrtaceae) (Weir et al. 2012); *Aeschynomene falcata* (Fabaceae) (Shivas et al. 2016); *Allium cepa* and *A. fistulosum* (Amaryllidaceae) (Matos et al. 2017; Lopes et al. 2021); *Anacardium occidentale* (Anacardiaceae) (Velooso et al. 2018); *Annona macrophyllata* (as *A. diversifolia*), *A. muricata* and *A. squamosa* (Annonaceae) (Weir et al. 2012; Álvarez et al. 2014; Costa et al. 2019); *Buxus microphylla* var. *japonica* (Buxaceae) (Singh et al. 2015); *Campomanesia phaea* (Myrtaceae) (Santos et al. 2017); *Carapichea ipecacuanha* (Rubiaceae) (Ferreira et al. 2020); *Coffea arabica* (Rubiaceae) (Shivas et al. 2016; Cristóbal-Martínez et al. 2017); *Copernicia prunifera* (Arecaceae) (Araújo et al. 2018); *Cyclamen persicum* (Primulaceae) (Sharma et al. 2016); *Fragaria* × *ananassa* (Rosaceae) (Weir et al. 2012); *Limonium* sp. (Plumbaginaceae) (Weir et al. 2012); *Malpighia emarginata* (Malpighiaceae) (Bragança et al. 2014); *Malus domestica* (Rosaceae) (Alaniz et al. 2015; Munir et al. 2016); *Mangifera indica* (Anacardiaceae) (Sharma et al. 2013; Pardo-De la Hoz et al. 2016); *Manihot esculenta* (Euphorbiaceae) (Oliveira et al. 2018); *Manilkara zapota* (Sapotaceae) (Martins et al. 2018); *Musa* sp. (Musaceae) (Vieira et al. 2017); *Olea europaea* (Oleaceae) (Weir et al. 2012; Lima et al. 2020; Moreira et al. 2021); *Persea americana* (Lauraceae) (Sharma et al. 2017); *Punica granatum* (Lythraceae) (Shivas et al. 2016; Xavier et al. 2019); *Quercus* sp. (Fagaceae) (Weir et al. 2012); *Stylosanthes guianensis* and *S. viscosa* (Fabaceae) (Weir et al. 2012); *Theobroma cacao* (Malvaceae) (Rojas et al. 2010). *Colletotrichum theobromicola* is thus a predominantly tropical and sub-tropical fungus (Supplementary data 9, panel O), with a growing host range, and of pathological relevance.

Colletotrichum ti B. Weir and P.R. Johnst., *Stud. Mycol.* 73: 171 (2012)

Colletotrichum ti is a fungus exhibiting pathogenic host specificity to *Cordyline australis* (Asparagaceae) and found only in New Zealand (Weir et al. 2012). There are other

species of *Colletotrichum* known from *Cordyline* (although not from New Zealand) which, along with the absence of recent reports of *C. ti*, raise concern about the conservation status of this species.

Colletotrichum tropicale E.I. Rojas, S.A. Rehner and Samuels, *Mycologia* 102(6): 1331 (2010)

Originally described as a fungus occurring as a leaf endophyte of several host species in tropical forests of Panama (Rojas et al. 2010), *Colletotrichum tropicale* has been identified from numerous hosts in many parts of the world (Supplementary data 9, panel P): *Anacardium occidentale* (Anacardiaceae) in Brazil (Velooso et al. 2018); *Annona cherimola* and *A. muricata* (Annonaceae) in Brazil, Colombia, Cuba and Panama (Rojas et al. 2010; Álvarez et al. 2014; García and Manzano 2017; Costa et al. 2019); *Areca catechu* (Arecaceae) in China (Cao et al. 2020); *Capsicum annuum* and *C. frutescens* (Solanaceae) in Indonesia and Brazil respectively (De Silva et al. 2017a, 2019); *Cattleya* spp. (Orchidaceae) in Brazil (Silva-Cabral et al. 2019); *Coffea* sp. (Rubiaceae) in China (Cao et al. 2019a); *Copernicia prunifera* (Arecaceae) in Brazil (Araújo et al. 2018); *Cordia alliodora* (Boraginaceae) in Panama (Rojas et al. 2010); *Ficus binnendijkii* (Moraceae) in China (Kong et al. 2020); *Licania tomentosa* (Chrysobalanaceae) in Brazil (Lisboa et al. 2018); *Litchi chinensis* (Sapindaceae) in Japan (Weir et al. 2012); *Mangifera indica* (Anacardiaceae) in Brazil, China and Mexico (Lima et al. 2013; Li et al. 2019b; Tovar-Pedraza et al. 2020); *Manihot dichotoma* and *M. epruinosa* (Euphorbiaceae) in Brazil (Oliveira et al. 2016); *Musa* sp. (Musaceae) in Brazil (Vieira et al. 2017); *Myrciaria dubia* (Myrtaceae) in Brazil (Matos et al. 2020); *Passiflora edulis* in Brazil (Silva et al. 2021a, b); *Persea americana* (Lauraceae) in Mexico (Fuentes-Aragón et al. 2020); *Plinia cauliflora* (as *Myrciaria cauliflora*, Myrtaceae) in Japan (Taba et al. 2020); *Nelumbo nucifera* (Nelumbonaceae) in China (Xavier et al. 2018); *Origanum vulgare* (Lamiaceae) in Mexico (Ayvar-Serna et al. 2020); *Pennisetum purpureum* (Poaceae) in Thailand (Manamgoda et al. 2013); *Punica granatum* (Lythraceae) in Brazil (Silva-Cabral et al. 2019); *Sauropus androgynus* (Phyllanthaceae) in China (Liu et al. 2018); *Theobroma cacao* (Malvaceae) in Panama (Rojas et al. 2010); *Trichilia tuberculata* (Meliaceae) in Panama (Rojas et al. 2010); *Viola surinamensis* (Violaceae) in Panama (Rojas et al. 2010); human eye (Hung et al. 2020). *Colletotrichum tropicale* is thus a cosmopolitan and polyphagous species, of contemporary widespread occurrence.

Colletotrichum viniferum L.J. Peng, L. Cai, K.D. Hyde and Z-Y. Ying, *Mycoscience* 54: 36 (2013)

Colletotrichum viniferum was described as a pathogen of grapes (*Vitis vinifera*) in China (Peng et al. 2013), where it is the most prevalent and virulent causal agent of grape anthracnose (Yan et al. 2015). The fungus was subsequently recorded

from grapevine in Korea (Oo and Oh 2017a), from *Hopea odorata* (Dipterocarpaceae) in Bangladesh (Rashid et al. 2020) and from chilli (*Capsicum* sp.; Diao et al. 2017), strawberry (*Fragaria* × *ananassa*; He et al. 2019) and walnut (*Juglans regia*; He et al. 2019) in China. Considering the geographical distribution currently known for this fungus (Supplementary data 9, panel Q), along with the high virulence to grapevines and the expanding host range, *Colletotrichum viniferum* should be regarded with concern regarding its pathological relevance and potential quarantine status.

Colletotrichum wuxiense Y.C. Wang, X.C. Wang and Y.J. Yang, *Sci. Rep.* **6**: 35287 (2016)

Colletotrichum wuxiense was described based on an isolate obtained from diseased leaves of *Camellia sinensis* (Theaceae) in China in 2014 (Wang et al. 2016) and subsequently identified associated to anthracnose symptoms on *Pyrus pyrifolia* (Rosaceae) also in China, in 2016 (Fu et al. 2019). Considering the large number of species of *Colletotrichum* known from both hosts, further surveys are important to reveal the pathological and ecological relevance of *C. wuxiense*, as well as its conservation status.

Colletotrichum xanthorrhoeae R.G. Shivas, Bathgate and Podger, *Mycol. Res.* **102**: 280 (1998)

Colletotrichum xanthorrhoeae was described based on isolates obtained from *Xanthorrhoea* spp. (Xanthorrhoeaceae) in Australia in the 1990s (Shivas et al. 1998; Weir et al. 2012), but no additional records have been reported ever since. The current conservation status of *C. xanthorrhoeae* is therefore of concern.

Colletotrichum xishuangbannaense N.I. de Silva, Lumyong & K.D. Hyde, *Mycosphere* **12**(1):195 (2021)

Colletotrichum xishuangbannaense is known from a single isolate collected as an endophyte in leaves of *Magnolia candolii* (Magnoliaceae) in 2017 in China (De Silva et al. 2021a, b). There are no further records of this fungus and other species of *Colletotrichum* are known from this and other *Magnolia* spp., rendering the conservation status of this taxon of concern.

Colletotrichum yulongense C.L. Hou and X.T. Liu, *Phytotaxa* **394**: 285 (2019)

Colletotrichum yulongense is known only from a single occurrence, as an endophyte on leaves of *Vaccinium*

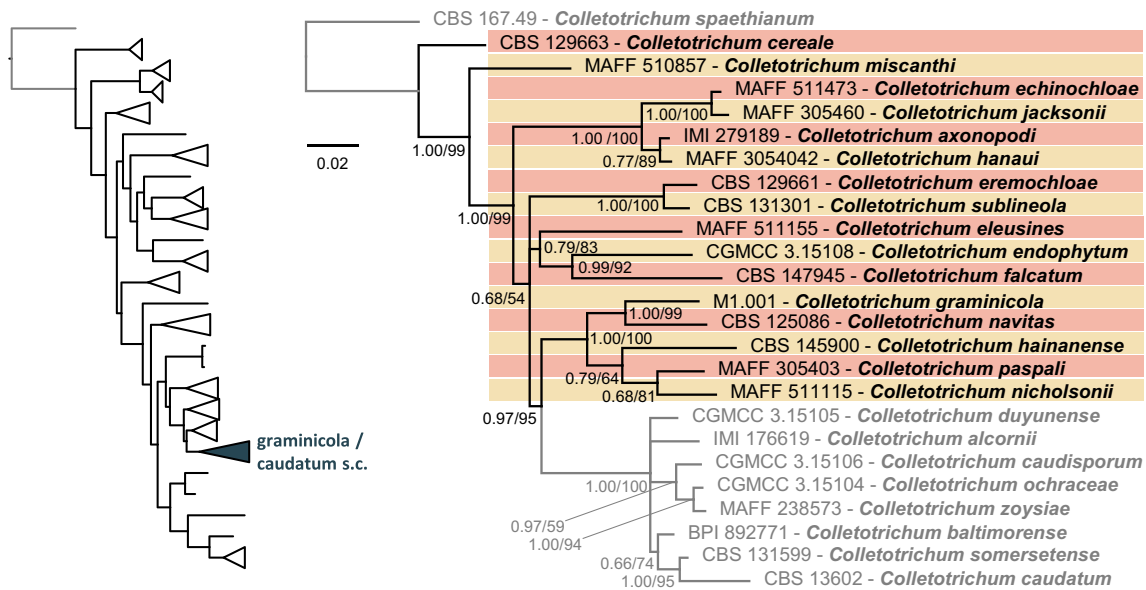

Fig. 12 Bayesian inference phylogenetic tree of the graminicola species complex and closely related singleton species. The tree was reconstructed from a combined multi-locus sequence alignment (ITS, *chs-1*, *act*, *tub2*, *sod2* and *apn2*). For each locus the alignment was performed with MAFFT v7.450 (Katoh and Standley 2013), exported to MEGA7 (Kumar et al. 2016) and the best-fit substitution model

calculated. Phylogenetic analyses were performed with FastTree2 v2.1.10 (Price et al. 2010) and MrBayes 3.2.6 (Ronquist et al. 2012). Bayesian posterior probability (BPP) and Maximum-Likelihood (ML) bootstrap values (above 0.50) are reported next to the node. The scale bar represents the number of expected substitutions per site. GenBank accession numbers are listed in Supplementary file 1

dunalianum var. *urophyllum* in China in 2013 (Wang et al. 2019b). There are other species of *Colletotrichum* occurring on *Vaccinium*, suggesting that the ecological and conservation status of *C. yulongense* must be clarified.

The graminicola species complex

Firstly described by Cannon et al. (2012) and in agreement with studies published by Crouch et al. (2009a, b), the graminicola complex is a well-defined monophyletic clade encompassing *Colletotrichum* species mainly associated with grasses and with characteristic widely falcate conidia.

MLST approaches initially revealed two major subclades within the graminicola clade (Crouch et al. 2009a, b). The first one is represented only by *Colletotrichum cereale*, a species associated with C3 grasses as either pathogens or endophytes (Crouch et al. 2009b). The second subclade encompasses apparently host-specific species associated with C4 grasses. More recently a third clade has been recognised and described as the caudatum species complex (see the section above). Currently the graminicola complex encompasses 16 species (Fig. 12) pathogenic to different lineages of Poaceae but also endophytes of Poaceae and Orchidaceae (both monocot plants). Several of the species included in the graminicola clade are of major importance, including *C. falcatum* on sugarcane, *C. graminicola* on maize and *C. sublineola* on *Sorghum* species. *Colletotrichum cereale* and *C. eremochloae* are pathogens of cultivated turfgrasses (Crouch and Beirn 2009). Beside the economic impact, the maize pathogen *C. graminicola* is an important model system (O'Connell et al. 2012).

Colletotrichum axonopodi J.A. Crouch, B.B. Clarke, J.F. White and B.I. Hillman, *Mycologia* **101**: 727 (2009)

There are four records for this species, collected in the first half of the twentieth century in the USA and Honduras and in 1983 in Australia, on *Axonopodus* spp. (Poaceae) (Crouch et al. 2009a). Although anthracnose of *Axonopus* was associated to *C. axonopodi* (Crouch and Beirn 2009), more recently *C. hainanense* was described as an additional causal agent of this disease (Zhang et al. 2020c). The current conservation status of *C. axonopodi* is therefore uncertain and of concern.

Colletotrichum cereale Manns, *Proc. Indiana Acad. Sci.*: 111 (1908)

Besides being a pathogen of grasses (Poaceae) throughout the world (Crouch et al. 2009a) (Supplementary data 10, panel A) (inspite of scarce records; Zhao et al. 2021b), *C.*

cereale was also reported as an endophyte from *Bletilla ochracea* (Orchidaceae) in China in 2006 (Tao et al. 2013).

Colletotrichum echinochloae Moriwaki and Tsukib., *Mycoscience* **50**: 275 (2009)

Colletotrichum echinochloae is only known from *Echinochloa utilis* (Poaceae) in Japan, collected over the years (Moriwaki and Tsukiboshi 2009). This fungus seems to be host-specific and geographically-confined, suggesting its ecological status to be under survey.

Colletotrichum eleusines Pavgi and U.P. Singh, *Mycopath. Mycol. Appl.* **27**: 85 (1965)

Colletotrichum eleusines is known from few and ancient (1936 and 1977) records, collected from *Eleusine indica* (Poaceae) in the USA and Japan (Crouch et al. 2009a). No other species of *Colletotrichum* have been recorded from this host, but the lack of recent reports of *C. eleusines* raises serious concern on its conservation status.

Colletotrichum endophytum G. Tao, Zuo Y. Liu and L. Cai, *Fungal Divers.* **61**: 152 (2013)

Colletotrichum endophytum is known only from two isolates collected from healthy leaves of *Bletilla ochracea* (Orchidaceae) in two locations in China in 2006 (Tao et al. 2013). No additional occurrences of *C. endophytum* were recorded thereafter, and several species of *Colletotrichum* occur on *Bletilla* (and even more so on orchids), rendering the conservation status of *C. endophytum* of great concern.

Colletotrichum eremochloae J.A. Crouch and Tomaso-Pet., *Mycologia* **104**: 1092 (2012)

Colletotrichum eremochloae has been recorded in the USA (including on a shipment from China in 1923) in different moments during the twentieth century and more recently in 2007 associated to anthracnose symptoms on *Eremochloa ophiuroides* (Poaceae) (Crouch and Tomaso-Peterson 2012). Although the fungus seems to be host specific, its seldom occurrence raises concern on its conservation status.

Colletotrichum falcatum Went, *Archiv, voor de Java Suiker-rind.* **1**: 265 (1893)

Colletotrichum falcatum is the causal agent of red rot of sugarcane, found in all continents were the host plant (*Saccharum officinarum*) is cultivated (Crouch et al. 2009a) (Supplementary data 10, panel B).

Colletotrichum graminicola (Ces.) G.W. Wilson, *Phytopathology* **4**: 110 (1914)

Colletotrichum graminicola is considered a pathogen of maize (*Zea mays*, Poaceae), reported from different parts of the world (Crouch et al. 2009a) (Supplementary data 10, panel C). Recent reports are mostly from Europe, including Bosnia and Herzegovina, Portugal and Switzerland (Sukno et al. 2014; Sanz-Martín et al. 2016; Cuevas-Fernández et al. 2019), but also from China (Duan et al. 2019). The fungus is also reported as a human opportunistic pathogen (Valenzuela-Lopez et al. 2018).

Colletotrichum hanaui J.A. Crouch, B.B. Clarke, J.F. White and B.I. Hillman, *Mycologia* **101**: 728 (2009)

The species *Colletotrichum hanaui* was defined to accommodate fungi isolated from *Digitaria ciliaris* and *D. sanguinalis* (Poaceae) in the USA and Japan in the 1940s and in 1975, respectively (Crouch et al. 2009a). Although there are no other species of *Colletotrichum* recorded on *Digitaria* spp., the lack of contemporary records of *C. hanaui* raises serious concerns on the conservation status of this taxon.

Colletotrichum hainanense W. Zhang and X. L. Niu, *Plant Dis.* **104**:1744 (2020)

Colletotrichum hainanense was recently named to accommodate fungi causing anthracnose of *Axonopus compressus* (Poaceae) in China in 2015 (Zhang et al. 2020c). *Colletotrichum axonopodi* is also associated to anthracnose in this host, rendering the conservation status of *C. hainanense* of concern.

Colletotrichum jacksonii J.A. Crouch, B.B. Clarke, J.F. White and B.I. Hillman, *Mycologia* **101**: 729 (2009)

Colletotrichum jacksonii is known from *Echinochloa esculenta* (Poaceae) in Japan and *E. crus-galli* in the USA, recorded respectively in the 1977–1985 and in the 1912–1943 periods (Crouch et al. 2009a). The lack of recent records, along with the identification of a different species (*C. echinochloae*) more recently in Japan, raises serious concerns on the conservation status of *C. jacksonii*.

Colletotrichum miscanthi J.A. Crouch, B.B. Clarke, J.F. White and B.I. Hillman, *Mycologia* **101**: 729 (2009)

Originally defined based on an isolate obtained from *Miscanthus sinensis* (Poaceae) in Japan in 1972 (Crouch et al. 2009a), the fungus was detected thereafter only once, as an endophyte on *Bletilla ochracea* (Orchidaceae) in China in 2006 (Tao et al. 2013). *Colletotrichum miscanthi* is thus a species of elusive pathological relevance and with its conservation status of high concern.

Colletotrichum navitas J.A. Crouch, *Mycol. Res.* **113**: 1417 (2009)

Crouch et al. (2009b) designated the species *Colletotrichum navitas* based on numerous isolates collected from the USA on *Panicum virgatum* (Poaceae) throughout the twentieth century, as well as on *P. crus-galli*, *P. curtisii* and *P. hemitomon*. There are no records of the fungus outside of the USA, suggesting further surveys to ascertain the geographical distribution and current conservation status of *C. navitas*.

Colletotrichum nicholsonii J.A. Crouch, B.B. Clarke, J.F. White and B.I. Hillman, *Mycologia* **101**: 730 (2009)

Colletotrichum nicholsonii is known from *Paspalum dilatatum* (Poaceae) from Japan, New Zealand and the USA, with isolates collected between 1965 and 1975 (Crouch et al. 2009a). Although *Paspalum dilatatum* is a cosmopolitan plant, no additional occurrences of *C. nicholsonii* have been recorded since 1975, indicating that the current existence of this species in nature must be scrutinised.

Colletotrichum paspali J.A. Crouch, B.B. Clarke, J.F. White and B.I. Hillman, *Mycologia* **101**: 730 (2009)

Colletotrichum paspali is known only from two records, collected in the 1970s, on *Paspalum notatum* (Poaceae) in Japan (Crouch et al. 2009a). There are no other species of *Colletotrichum* recorded from *Paspalum notatum*, but *C. nicholsonii* has also been recorded from *Paspalum dilatatum* in Japan. Considering the absence of recent reports of *C. paspali*, its conservation status is of serious concern.

Colletotrichum sublineola Henn. ex Sacc. and Trotter, *Syll. Fung.* (Abellini) **22**: 1206 (1913)

Colletotrichum sublineola is the sorghum (*Sorghum* spp.) anthracnose pathogen (Crouch and Tomaso-Peterson 2012). Effective records are known from Africa, America and Korea (Supplementary data 10, panel D), but the disease is known from virtually the entire sorghum cultivation area (Crouch and Tomaso-Peterson 2012; Tsedaley et al. 2016; Xavier et al. 2018; Bunker et al. 2019; Choi et al. 2021). The fungus appears to be common, but a recent review on sorghum anthracnose is lacking.

The magnum species complex

The magnum complex is one of the most recently described species complexes (Damm et al. 2019). Sister clade of the orchidearum complex, the magnum species complex encompasses eight accepted species (Fig. 13). Whereas almost all of them have been reported only once or in one host in one

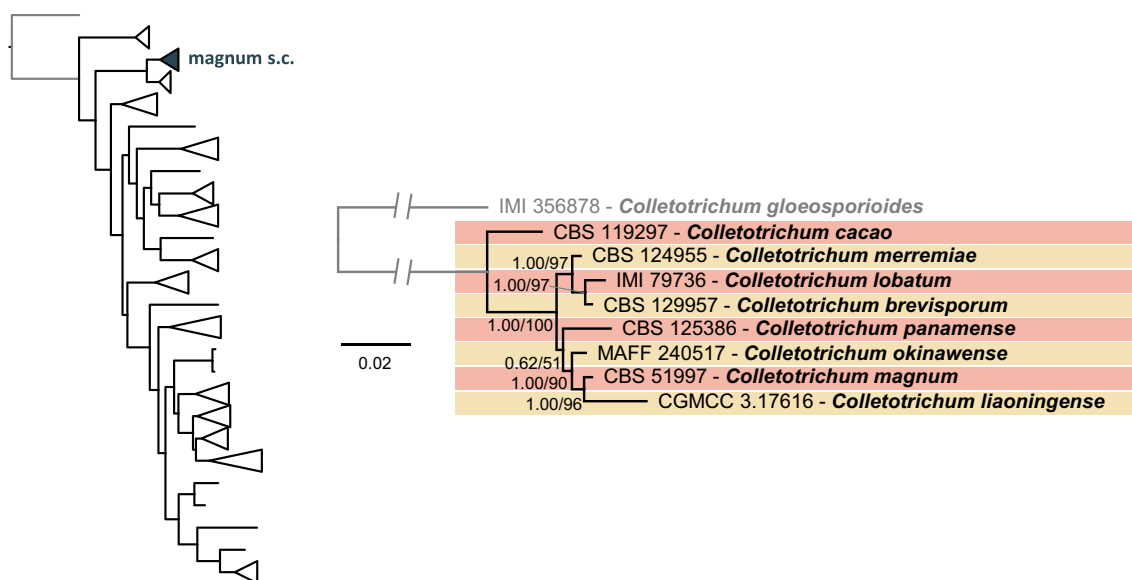

Fig. 13 Bayesian inference phylogenetic tree of the magnum species complex. The tree was reconstructed from a combined multi-locus sequence alignment (ITS, *gapdh*, *chs-1*, *his3*, *act* and *tub2*). For each locus the alignment was performed with MAFFT v7.450 (Kato and Standley 2013), exported to MEGA7 (Kumar et al. 2016) and the best-fit substitution model calculated. Phylogenetic analyses were

performed with FastTree2 v2.1.10 (Price et al. 2010) and MrBayes 3.2.6 (Ronquist et al. 2012). Bayesian posterior probability (BPP) and Maximum-Likelihood (ML) bootstrap values (above 0.50) are reported next to the node. The scale bar represents the number of expected substitutions per site. GenBank accession numbers are listed in Supplementary file 1

country, *Colletotrichum brevisporum* seems to be a quite common species as it has been associated with at least 20 plant species belonging to 18 genera (both monocots and eudicots) in Asia, Oceania and South America. Like for other uncommon or rare species, not much is available about the host spectrum, the specificity or the lifestyle of the other members of the complex.

Colletotrichum brevisporum Noireung, Phouliv., L. Cai and K.D. Hyde, *Cryptog. Mycol.* **33**: 350 (2012)

Colletotrichum brevisporum is recorded from several hosts in tropical and sub-tropical regions throughout the world (Damm et al. 2019) (Supplementary data 11), including: *Annona* sp. (Annonaceae) in Brazil (Costa et al. 2019); *Anthurium* sp. (Araceae) in Thailand (Damm et al. 2019); *Capsicum annuum* (Solanaceae) in China and Trinidad and Tobago (Liu et al. 2016c; Damm et al. 2019; Villafana et al. 2019) and *C. chinense* and *C. frutescens* in Brazil (Almeida et al. 2017; Oliveira et al. 2017; Silva et al. 2017b; Damm et al. 2019); *Carapichea ipecacuanha* (Rubiaceae) in Brazil (Ferreira et al. 2020); *Carica papaya* (Caricaceae) in Australia, Brazil and China (Vieira et al. 2013; Shivas et al. 2016; Duan et al. 2018a; Damm et al. 2019; Liu et al. 2019c); *Citrus medica* (Rutaceae) in China (Guarnaccia

et al. 2017); *Coffea* sp. (Rubiaceae) in China (Cao et al. 2019a); *Colocasia esculenta* (Araceae) in Mexico (Vásquez-López et al. 2019); *Glycine max* (Fabaceae) in China (Shi et al. 2021); *Lycium chinense* (Solanaceae) in Korea (Damm et al. 2019); *Momordica cochinchinensis* (Cucurbitaceae) in Thailand (Chai et al. 2018); *Neoregelia* sp. (Bromeliaceae) in Thailand (Damm et al. 2019); *Pandanus pygmaeus* (Pandanaaceae) in Thailand (Damm et al. 2019); *Passiflora edulis* (Passifloraceae) in Australia and China (Shivas et al. 2016; Du et al. 2017; Qiu et al. 2021); *Sechium edule* (Cucurbitaceae) in Brazil (Bezerra et al. 2016).

Colletotrichum cacao Damm, in *Stud. Mycol.* **92**: 1 (2019)

Colletotrichum cacao is known from a single isolate collected as an endophyte from *Theobroma cacao* in Costa Rica at an unknown date (Damm et al. 2019). Several other species of *Colletotrichum* are recorded on this host, raising great concern on the current ecological status of *C. cacao*.

Colletotrichum liaoningense Y.Z. Diao, C. Zhang, L. Cai and X.L. Liu, *Persoonia* **38**: 34 (2017)

Colletotrichum liaoningense occurs on chilli (*Capsicum* sp., Solanaceae) in China (Diao et al. 2017; Damm et al. 2019),

but it was recently identified in China associated to anthracnose on mango (*Mangifera indica*, Anacardiaceae) (Li et al. 2019b) and on *Solanum pseudocapsicum* (Solanaceae; Liu et al. 2021a). Both chilli and mango harbour many species of *Colletotrichum*, rendering the conservation status of *C. liaoningense* of concern.

Colletotrichum lobatum Damm, *Stud. Mycol.* **92**: 1 (2019)

Colletotrichum lobatum is known from a single isolate obtained from *Piper marginatum* f. *catalpifolium* (as *Piper catalpifolium*, Piperaceae) in Trinidad and Tobago in an unknown date (Damm et al. 2019). There are no further occurrences of *C. lobatum* recorded and several other species of *Colletotrichum* are known from *Piper* spp., raising serious concern on the conservation status of this species.

Colletotrichum magnum (S.F. Jenkins and Winstead) Rossman and W.C. Allen, *IMA Fungus* **7**:1 (2016)

Originally defined as a pathogen of watermelon (*Citrullus lanatus*, Cucurbitaceae) (Rossman et al. 2016), *Colletotrichum magnum* is seldom reported: it was identified causing anthracnose on papaya (*Carica papaya*, Caricaceae) in Mexico in 2014 (Tapia-Tussell et al. 2016) and on *Lobelia chinensis* (Campanulaceae) in China in 2014 (Li et al. 2013). Further surveys will convey additional information about the pathological relevance and conservation status of *Colletotrichum magnum*.

Colletotrichum merremiae Damm, *Stud. Mycol.* **92**: 1 (2019)

The species *Colletotrichum merremiae* was described based on an isolate occurring as a leaf endophyte of *Merremia umbellata* (Convolvulaceae) in Panama in 2004 (Damm et al. 2019). There are no additional records for this fungus, indicating that the conservation status of *C. merremiae* is of serious concern.

Colletotrichum okinawense Damm and Toy. Sato, *Stud. Mycol.* **92**: 1 (2019)

Colletotrichum okinawense was described based on two isolates collected from papaya (*Carica papaya*) stems/petioles

in Brazil and in Japan in 1892 and 2007 respectively (Damm et al. 2019). However, the fungus was subsequently re-identified in Brazil in 2018 associated to papaya fruit anthracnose (Dias et al. 2020). The scarcity of reports of *Colletotrichum okinawense* along with the large number of other species of *Colletotrichum* occurring on papaya renders the pathological relevance of this species uncertain and raises concern about its conservation status.

Colletotrichum panamense Damm, *Stud. Mycol.* **92**: 1 (2019)

Colletotrichum panamense is known from a single isolate, occurring as an epiphyte on *Merremia umbellata* (Convolvulaceae) in Panama in 2004 (Damm et al. 2019). There are no further records for this taxon and other species of *Colletotrichum* are known from this host, casting great concern on the conservation status of *C. panamense*.

The orbiculare species complex

Introduced by Cannon et al. (2012) as a small aggregate of only two species, the orbiculare species complex has been widely described by Damm et al. (2013) based on MLST and morphological characters. Analysis performed by the authors resulted in nine clades that confirmed four species previously known, *Colletotrichum lindemuthianum*, *C. malvarum*, *C. orbiculare* and *C. trifolii*, and recognised four new species from weeds, namely *C. bidentis*, *C. sidae*, *C. spinosum* and *C. tebeestii*. Most of them are known for their hemibiotrophic infection strategy and as destructive pathogens either of field crops or weeds (Fig. 14). While initially the species included in the orbiculare complex were considered host specific, new reports suggest that most of them are rather specialised, but not exclusive, to a group of hosts. Overall members of this complex have been associated with 19 host species belonging to 16 genera, with a vast majority of eudicot hosts and only one report on *Asparagus racemosus* (Asparagaceae, monocot). *Colletotrichum lindemuthianum* is a well-known bean pathogen and the most common species of the complex, followed by *C. orbiculare*, causal agent of anthracnose of Cucurbitaceae, and *C. trifolii*, a species pathogenic of alfalfa, red clover and mallow.

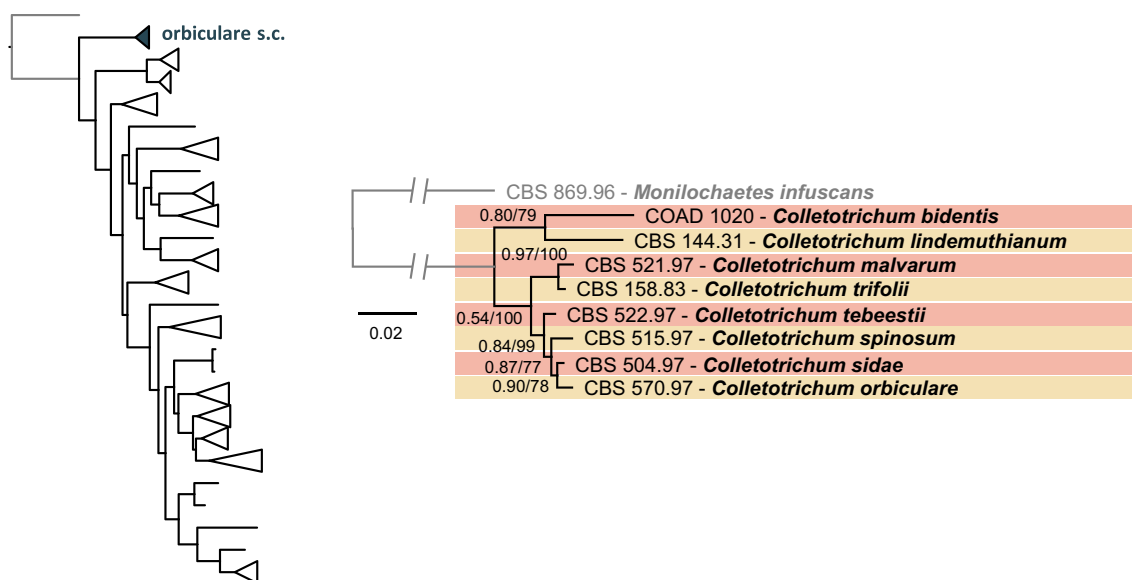

Fig. 14 Bayesian inference phylogenetic tree of the orbiculare species complex. The tree was reconstructed from a combined multi-locus sequence alignment (ITS, *gapdh*, *chs-1*, *his3*, *act*, *tub2* and *gs*). For each locus the alignment was performed with MAFFT v7.450 (Kato and Standley 2013), exported to MEGA7 (Kumar et al. 2016) and the best-fit substitution model calculated. Phylogenetic analy-

ses were performed with FastTree2 v2.1.10 (Price et al. 2010) and MrBayes 3.2.6 (Ronquist et al. 2012). Bayesian posterior probability (BPP) and Maximum-Likelihood (ML) bootstrap values (above 0.50) are reported next to the node. The scale bar represents the number of expected substitutions per site. GenBank accession numbers are listed in Supplementary file 1

Colletotrichum bidentis Damm, Guatimosim and Vieira, *Fungal Divers.* **61**: 34 (2013)

There is a single record for *Colletotrichum bidentis*, isolated from *Bidens subalternans* (Asteraceae) in Brazil in 2010 (Damm et al. 2013). *Bidens* spp. are recorded from all over the world, often as invasive weeds, but the conservation status of *C. bidentis* is of concern.

Colletotrichum lindemuthianum (Sacc. and Magnus) Briosi and Cavara, *Funghi Parass. Piante Colt. od Utili*, Fasc. 2: no. 50 (1889)

The common bean (*Phaseolus vulgaris* and *P. coccineus*, Fabaceae) anthracnose pathogen, *Colletotrichum lindemuthianum*, is found all over the world (Supplementary data 12, panel A), and it develops a singular race-dependent interaction with the host (Liu et al. 2013b; Padder et al. 2017).

Colletotrichum malvarum (A. Braun and Casp.) SouthW., *J. Mycol.* **6**: 116 (1891)

Only two strains were considered as belonging to *Colletotrichum malvarum* by Damm et al. (2013), obtained from

Malva sp. and *Lavatera trimestris* (Malvaceae) in Germany and UK respectively, with several other reports of anthracnose pathogens on Malvaceae either assigned to different species or requiring further investigation. No reports of *C. malvarum* have arose ever since, laying high concern over the conservation status of this species.

Colletotrichum orbiculare Damm, P.F. Cannon and Crous, *Fungal Divers.* **61**: 39 (2013)

Colletotrichum orbiculare was newly described by Damm et al. (2013) encompassing fungi occurring on (and as important pathogens of) the Cucurbitaceae *Cucumis melo*, *Cucurbita pepo* and *Lagenaria* spp. Recently the species was also recorded from other Cucurbitaceae such as *Benincasa hispida* in Australia (Shivas et al. 2016) and watermelon (*Citrullus lanatus*) in the USA (Rennberger et al. 2018) (Supplementary data 12, panel B).

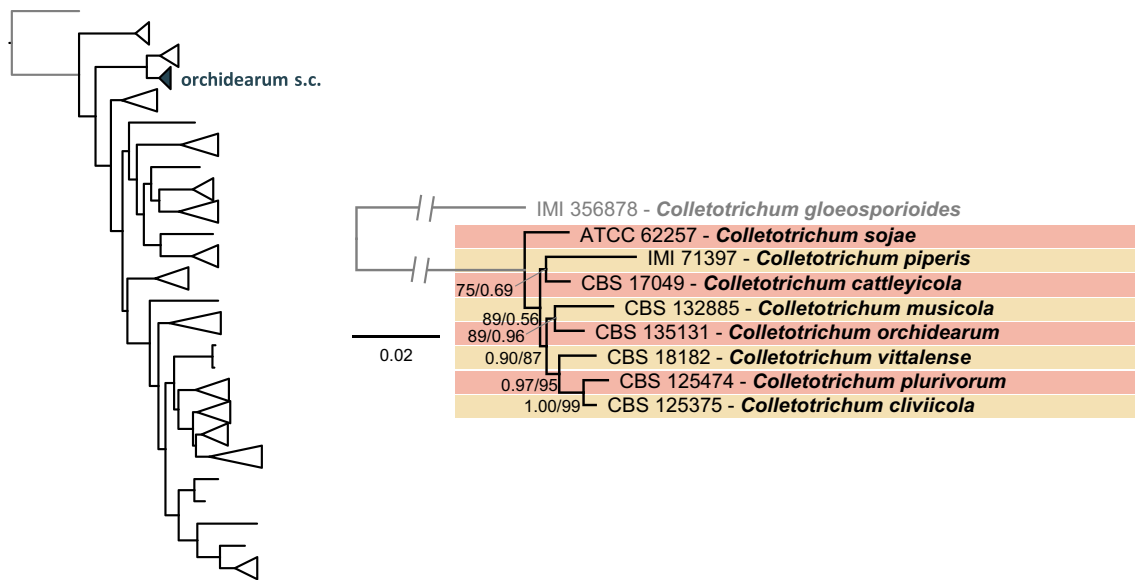

Fig. 15 Bayesian inference phylogenetic tree of the orchidearum species complex. The tree was reconstructed from a combined multi-locus sequence alignment (ITS, *gapdh*, *chs-1*, *his3*, *act* and *tub2*). For each locus the alignment was performed with MAFFT v7.450 (Kato and Standley 2013), exported to MEGA7 (Kumar et al. 2016) and the best-fit substitution model calculated. Phylogenetic analy-

ses were performed with FastTree2 v2.1.10 (Price et al. 2010) and MrBayes 3.2.6 (Ronquist et al. 2012). Bayesian posterior probability (BPP) and Maximum-Likelihood (ML) bootstrap values (above 0.50) are reported next to the node. The scale bar represents the number of expected substitutions per site. GenBank accession numbers are listed in Supplementary file 1

Colletotrichum sidae Damm and P.F. Cannon, *Fungal Divers.* **61**: 44 (2013)

Colletotrichum sidae is known only from *Sida spinosa* (Malvaceae) in the USA only (Damm et al. 2013). The scarcity of recent reports of *Colletotrichum sidae* raises concerns on its conservation status.

Colletotrichum spinosum Damm and P.F. Cannon, *Fungal Divers.* **61**: 46 (2013)

Damm et al. (2013) revised literature on the occurrence of *Colletotrichum spinosum*, revealing this fungus to be common in Australia and to occur also in Argentina on *Xanthium spinosum* (Asteraceae). However, there are no recent records of this fungus, while other species of *Colletotrichum* are reported from the host, suggesting further surveys to ascertain the conservation status of *C. spinosum*.

Colletotrichum tebeestii Damm and P.F. Cannon, *Fungal Divers.* **61**: 48 (2013)

Colletotrichum tebeestii was described based on a fungus isolated from *Malva pusilla* (Malvaceae) in Canada (Damm et al. 2013). Fungi from this species were developed as mycoherbicides, but there is a lack of current reports of this fungus, raising concern about the current conservation status of this species.

Colletotrichum trifolii Bain, *J. Mycol.* **12**: 193 (1906)

Colletotrichum trifolii is known from Fabaceae (*Medicago sativa* and *Trifolium pratense*) in the USA (Damm et al. 2013; Samac et al. 2014), but also from *Malva crispa* and *M. sylvestris* (Malvaceae) in China (Zhou et al. 2014; Liu et al. 2017c) and, as an endophyte, from *Viola odorata* (Violaceae) in India (Katoch et al. 2017). Future surveys may improve the knowledge on the host range and geographic distribution of *C. trifolii*.

The orchidearum species complex

The orchidearum complex is the last of the four most recently described species complexes (Damm et al. 2019; Bhunjun et al. 2021). Sister clade of the magnum complex, the orchidearum species complex encompasses eight accepted species (Fig. 15). Unlike the other two closely related aggregates, most of the species encompassing this complex are quite common and polyphagous. Overall members of this complex have been associated with 35 plant species belonging to 31 genera (almost the same proportion between eudicots and monocots). Interestingly several species belonging to this clade (*Colletotrichum sojae*, *C. plurivorum* and *C. musicola*) have been reported to be serious problems of an important crop such as soybean (Rogério et al. 2020).

Colletotrichum cattleyicola Damm and Toy. Sato, *Stud. Mycol.* **92**: 1 (2019)

Colletotrichum cattleyicola is known from unspecified species of *Cattleya* (Orchidaceae; root and stem), collected in Belgium prior to 1949 and in Japan around 2000 (Damm et al. 2019). The pathological status of *Colletotrichum cattleyicola* is unknown and its conservation status is of concern, as several other species of *Colletotrichum* are recorded on orchids.

Colletotrichum cliviicola Damm and Crous, *Stud. Mycol.* **92**: 1 (2019)

Colletotrichum cliviicola, recently described in replacement of *C. cliviae* Yan L. Yang et al., includes isolates obtained from *Clivia* spp. (Amaryllidaceae) in China in 2008 and in South Africa in 2012 (Damm et al. 2019), along with isolates obtained in China from *Pennisetum americanum* × *P. purpureum* (Poaceae) (Han et al. 2019) and *Mangifera indica* (Li et al. 2019b) (Supplementary data 13, panel A).

Colletotrichum musicola Damm, *Stud. Mycol.* **92**: 1 (2019)

The species *Colletotrichum musicola* was defined based on an isolate collected from *Musa* sp. (Musaceae) in Mexico in 2008 (Damm et al. 2019). Subsequently the fungus was identified associated to leaf anthracnose of taro (*Colocasia esculenta*, Araceae) in 2017, also in Mexico (Vásquez-López et al. 2019). So far restricted to Mexico, the host range of *Colletotrichum musicola* remains to be elucidated, along with its pathological relevance and conservation status.

Colletotrichum orchidearum Allesch., *Rabenh. Krypt.-Fl.*, Edn 2 (Leipzig) **1**: 563 (1903)

Damm et al. (2019) provide a description of *Colletotrichum orchidearum* and placed *C. hymenocallidicola* and *C. aracearum* as its synonyms. As such, *C. orchidearum* is known from *Dendrobium nobile* and *Eria javanica* (Orchidaceae) in the Netherlands and Germany respectively, *Epipremnum aureum*, *Monstera deliciosa* and *Philodendron bipinnatifidum* (as *P. selloum*) (Araceae) in Iran and China respectively and *Hymenocallis* sp. (Amaryllidaceae) in Thailand (Ariyawansa et al. 2015; Hou et al. 2016; Damm et al. 2019). Thus, the geographic distribution (Supplementary data 13, panel B) and host range of *C. orchidearum*

requires further investigation in order to clarify its conservation status.

Colletotrichum piperis Petch, *Ann. R. bot. Gdns Peradeniya* **6**: 239 (1917)

Damm et al. (2019) listed four isolates under *Colletotrichum piperis*, collected from *Piper betle*, *P. nigrum* and *P. umbellatum* (Piperaceae) in China, Malaysia, Sri Lanka and Puerto Rico, all obtained at least over 70 years ago. Although scarce, other species of *Colletotrichum* have been recorded from *Piper*, raising serious concerns about the conservation status of *Colletotrichum piperis* and suggesting that it may no longer exist in nature.

Colletotrichum plurivorum Damm, Alizadeh and Toy. Sato, *Stud. Mycol.* **92**: 1 (2019)

Colletotrichum plurivorum was recently described by Damm et al. (2019) accommodating fungi previously belonging to *C. sichuanensis* but regarding *C. cliviicola* as a distinct species, contrary to the study by Douanla-Meli et al. (2018). Other recent works added further reports of *Colletotrichum plurivorum*, being this species currently known from: chilli (*Capsicum annum*, Solanaceae) in China (as *Colletotrichum sichuanensis*; Liu et al. 2016c) and Thailand (De Silva et al. 2019); papaya (*Carica papaya*, Caricaceae) in China and Mexico (Sun et al. 2019b; García-Estrada et al. 2020); lemon (*Citrus limon*, Rutaceae) in Vietnam (Damm et al. 2019); coffee (*Coffea* sp., Rubiaceae) in Vietnam (Damm et al. 2019); soybean (*Glycine max*, Fabaceae) in Myanmar (Zaw et al. 2020); cotton (*Gossypium* sp., Malvaceae) in Brazil (Damm et al. 2019); cassava (*Manihot esculenta*, Euphorbiaceae) in Brazil (as *Colletotrichum sichuanensis*; Oliveira et al. 2020) and China (Liu et al. 2019a); *Myrianthus arboreus* (Urticaceae) in Cameroon (Damm et al. 2019); lima bean (*Phaseolus lunatus*, Fabaceae) in Benin and Brazil (as *C. sichuanensis*) and common bean (*P. vulgaris*) in Iran (Cavalcante et al. 2018; Damm et al. 2019); *Pyrus bretschneideri* (Rosaceae) in China (Fu et al. 2019); peace lily (*Spathiphyllum wallisii*, Araceae) in Iran (Damm et al. 2019). *Colletotrichum plurivorum* is thus a cosmopolitan and polyphagous fungus (Supplementary data 13, panel C), found on numerous agricultural crops. The numerous recent reports suggest that this fungus may be expanding and further occurrence notices are expected to arise in the near future.

Colletotrichum sojae Damm and Alizadeh, *Stud. Mycol.* **92**: 35 (2019)

Specimens identified as *Colletotrichum sojae* have been collected since 1980 up to present days from soybean (*Glycine max*, Fabaceae) in Iran, Italy, Serbia, and the USA, but also from other Fabaceae such as alfalfa (*Medicago sativa*) in the USA, common bean (*Phaseolus vulgaris*) in Iran and cowpea (*Vigna unguiculata*) also in Iran (Damm et al. 2019) (Supplementary data 13, panel D). Recently the fungus was reported from *Panax quinquefolium* (Araliaceae) in China (Guan et al. 2021). Additional surveys are likely to clarify the host range, pathological relevance and geographic distribution of *Colletotrichum sojae*.

Colletotrichum vittalense Damm, *Stud. Mycol.* **92**: 38 (2019)

Colletotrichum vittalense is a taxon of obscure existence. It is known from two isolates collected nearly one century ago, one from cacao (*Theobroma cacao*) in India and the other from an unspecified Orchidaceae plant from an unknown location (Damm et al. 2019). Several species of *Colletotrichum* are known from cacao and orchids. No other fungus clustering in *C. vittalense* have been documented in spite of extensive studies on both hosts, suggesting that this taxon may be extinct.

The spaethianum species complex

The spaethianum species complex was first described by Cannon et al. (2012) as an aggregate containing five species, four of which are associated with petaloid monocot plants, and none appears to have economic importance. The spaethianum is as a sister group to the graminicola complex. This complex was recognised as a distinct assemblage by Damm et al. (2009) in their work on *Colletotrichum* with curved conidia associated with non-grass species. Since it was firstly introduced, more species belonging to this group have been described, reaching nine accepted species (Fig. 16). Overall members of this group have been associated with 37 species belonging to 28 genera, mostly monocots (65%).

Colletotrichum bletillae G. Tao, Zuo Y. Liu and L. Cai, *Fungal Divers.* **61**: 144 (2013)

There is a single record for *Colletotrichum bletillae*, collected as an endophyte from *Bletilla ochracea* (Orchidaceae) in China in 2006 (Tao et al. 2013). The authors refer 17 different endophytic *Colletotrichum* species in the host species, thus rendering the conservation status *C. bletillae* of great concern.

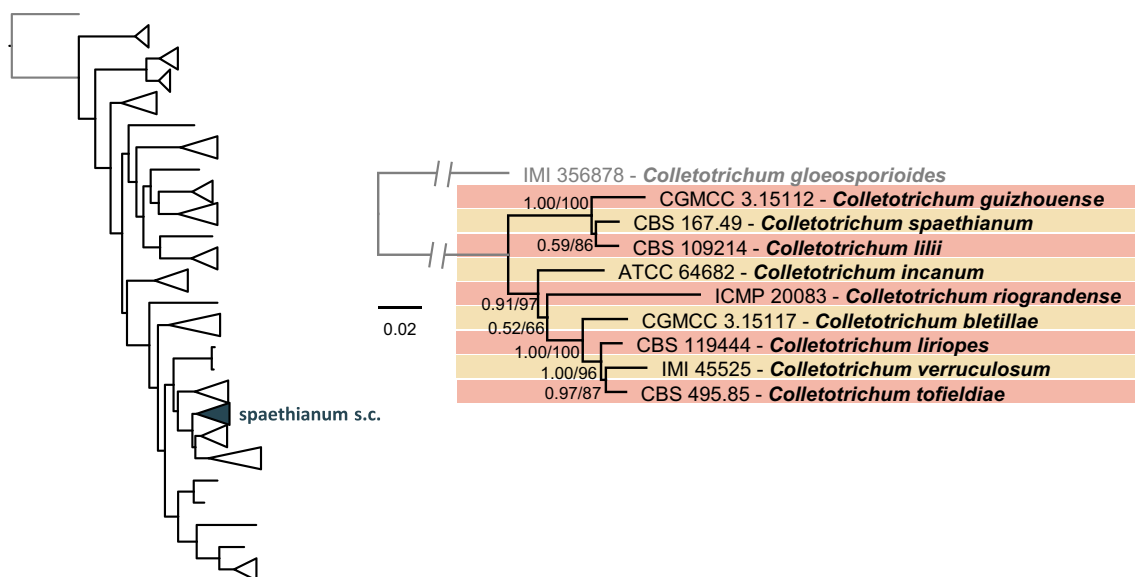

Fig. 16 Bayesian inference phylogenetic tree of the spaethianum species complex. The tree was reconstructed from a combined multi-locus sequence alignment (ITS, *gapdh*, *chs-1*, *his3*, *act* and *tub2*). For each locus the alignment was performed with MAFFT v7.450 (Kato and Standley 2013), exported to MEGA7 (Kumar et al. 2016) and the best-fit substitution model calculated. Phylogenetic analy-

ses were performed with FastTree2 v2.1.10 (Price et al. 2010) and MrBayes 3.2.6 (Ronquist et al. 2012). Bayesian posterior probability (BPP) and Maximum-Likelihood (ML) bootstrap values (above 0.50) are reported next to the node. The scale bar represents the number of expected substitutions per site. GenBank accession numbers are listed in Supplementary file 1

Colletotrichum guizhouense G. Tao, Zuo Y. Liu and L. Cai, *Fungal Divers.* **61**: 152 (2013)

The species *Colletotrichum guizhouense* was designated to accommodate fungi occurring as endophytes of *Bletilla ochracea* (Orchidaceae) in China (Tao et al. 2013). Subsequently the fungus was identified as an endophyte on *Huperzia phlegmaria* (= *Phlegmariurus phlegmaria*, Lycopodiaceae) in China exhibiting pharmaceutical interest. There are numerous species of *Colletotrichum* occurring on *Bletilla* spp., rendering the conservation status of *C. guizhouense* of concern.

Colletotrichum incanum H.C. Yang, J.S. Haudenshield and G.L. Hartman, *Mycologia* **106**: 38 (2014)

The species *Colletotrichum incanum* was defined based on isolates obtained from diseased soybean (*Glycine max*) petioles in the USA (Yang et al. 2014) and subsequently reported from *Capsicum* sp. in China (Diao et al. 2017). The current pathological relevance, geographic distribution and conservation status of *C. incanum* require further investigation.

Colletotrichum lilii Plakidas ex Boerema and Hamers, *Neth. Jl Pl. Path.* **94**: 12 (1988)

Colletotrichum lilii is recurrently found associated to the black scale disease of *Lilium* (Liliaceae) bulbs. It has been reported from the USA, the Netherlands and Japan (Damm et al. 2009), and more recently from Russia (Nikitin et al. 2018). Although seldom reported, this pathogen seems to be present in different parts of the world. Nevertheless, the presence of other species of *Colletotrichum* in *Lilium* suggests further surveys to ascertain the conservation status of *C. lilii*.

Colletotrichum liriopes Damm, P.F. Cannon and Crous, *Fungal Divers.* **39**: 71 (2009)

The species *Colletotrichum liriopes* was defined based on fungi isolated from *Liriope muscari* (Asparagaceae) in Mexico (Damm et al. 2009) and subsequently enlarged with fungi obtained from the Orchidaceae *Eria coronaria*, *Bletilla ochracea* and *Pleione bulbocodioides* in China (Yang et al. 2012b; Tao et al. 2013), the Asteraceae *Erigeron philadelphicus* and *Laphangium affine* (= *Gnaphalium affine*) in Japan (Sato et al. 2015), the Asparagaceae *Rohdea japonica* in Japan, Korea and the USA (Kwon and Kim 2013; Sato et al. 2015; Trigiano et al. 2018), *Ophiopogon japonicus* in China (Wang and Wang 2021) and *Liriope cymbidiomorpha* and *L. spicata* in China and *L. muscari* in Korea (Oo and Oh 2017b; Chen et al. 2019c; Yang et al. 2020), as well as from *Hemerocallis fulva* (Xanthorrhoeaceae) in China (Yang et al. 2012b), *Fagopyrum esculentum* (Polygonaceae) in China (Chen et al. 2021) and *Rumex acetosa* (Polygonaceae) in

Japan (Sato et al. 2015). *Colletotrichum liriopes* is thus a fungus that has been recurrently reported in recent years, mostly from Asparagaceae and Orchidaceae in Asia (Supplementary data 14, panel A).

Colletotrichum riograndense D.M. Macedo, R.W. Barreto, O.L. Pereira and B.S. Weir, *Australasian Plant Pathol.* **45**: 49 (2016)

Colletotrichum riograndense is known from a single record obtained from *Tradescantia* viz. *fluminensis* (Commelinaceae) leaves in Brazil in 2008 (Macedo et al. 2016). Although there are no other species of *Colletotrichum* recorded from *Tradescantia*, the absence of additional records of *C. riograndense* raises severe concerns about its conservation status.

Colletotrichum spaethianum (Allesch.) Damm, P.F. Cannon and Crous, *Fungal Divers.* **39**: 74 (2009)

Colletotrichum spaethianum is known mostly from China, Korea and Japan, but it has been reported also from Brazil, Germany and India (Supplementary data 14, panel B), from several hosts: *Allium fistulosum* and *A. ledebourianum* (Amaryllidaceae) (Sato et al. 2015; Santana et al. 2016; Salunkhe et al. 2018a); *Anemarrhena asphodeloides* (Asparagaceae) (Okorley et al. 2019); *Atractylodes japonica* (Asteraceae) (Guan et al. 2018); *Convallaria keiskei* (Asparagaceae) (Ahn et al. 2017); *Crinum latifolium* (Amaryllidaceae) (Sato et al. 2015); *Dianthus chinensis* (Caryophyllaceae) (Sato et al. 2015); *Hemerocallis citrina*, *H. flava* and *H. fulva* (Xanthorrhoeaceae) (Yang et al. 2012b; Vieira et al. 2014); *Hosta plantaginea*, *H. sieboldiana* and *H. ventricosa* (Asparagaceae) (Damm et al. 2009; Sato et al. 2015; Cheon and Jeon 2016; Sun et al. 2020a); *Hymenocallis littoralis* (Amaryllidaceae) (Yang et al. 2012b); *Iris × germanica* (Iridaceae) (Sato et al. 2015); *Kniphofia northiae* (Xanthorrhoeaceae) (Sato et al. 2015); *Lilium* spp. (Liliaceae) (Damm et al. 2009; Zhao et al. 2016b); *Paris polyphylla* (Melanthiaceae) (Zhong et al. 2020); *Peucedanum praeruptorum* (Apiaceae) (Guo et al. 2013); *Phaseolus vulgaris* (Fabaceae) (Yang et al. 2019b); *Polygonatum cyrtoneura*, *P. falcatum* and *P. odoratum* (Asparagaceae) (Sato et al. 2015; Liu et al. 2020b; Ma et al. 2021). Reported mostly from Asparagales hosts, it is noteworthy that records of *Colletotrichum spaethianum* on eudicotyledons (*Dianthus*, *Peucedanum* and *Phaseolus*) have occurred recently.

Colletotrichum tofieldiae (Pat.) Damm, P.F. Cannon and Crous, *Fungal Divers.* **39**: 77 (2009)

Colletotrichum tofieldiae has been reported either as a pathogen, a saprobe or an endophyte, on several hosts and locations (Supplementary data 14, panel C): symptomless

roots of *Arabidopsis thaliana* (Brassicaceae) in Spain (Hacquard et al. 2016); symptomless leaves of *Bletilla ochracea* (Orchidaceae) in China (Tao et al. 2013); *Dianthus* sp. (Caryophyllaceae) in the UK (Damm et al. 2009); *Grevillea crithmifolia* (Proteaceae) in Australia (Shivas et al. 2016); *Iris × germanica* (Iridaceae) in Australia (Shivas et al. 2016); dead stem of *Lupinus polyphyllus* (Fabaceae) in Germany (Damm et al. 2009); *Ornithogalum umbellatum* (Asparagaceae) in Japan (Sato et al. 2015); dead leaves of *Tofieldia* sp. and *T. calyculata* (Tofieldiaceae) in China and Switzerland respectively (Damm et al. 2009). *Colletotrichum tofieldiae* is thus a fungus with varied life styles recorded from several hosts and locations, suggesting that further studies many shed additional light on its conservation status, geographical distribution and ecological relevance.

Colletotrichum verruculosum Damm, P.F. Cannon and Crous, *Fungal Divers.* **39**: 81 (2009)

Colletotrichum verruculosum is known from a single fungus, isolated in 1951 from *Crotalaria juncea* (Fabaceae) in Zimbabwe (Damm et al. 2009). Although there are no other

species of *Colletotrichum* known from *Crotalaria*, the prolonged absence of additional records of this fungus raises serious concerns about its conservation status.

The truncatum species complex

Introduced by Cannon et al. (2012), the truncatum complex comprised only one common species, *Colletotrichum truncatum* (syn: *C. capsici*; Damm et al. 2009), which is reported as an economically destructive pathogen of many tropical crops including legumes such as soybean and solanaceous plants. As the taxonomy of this species complex has not been revised recently and besides the fact that this complex is quite small and encompasses four species (Fig. 17), its taxonomy is still confused and challenging for the most. An example is provided by *C. corchorum-capsularis*, a pathogen of *Corchorus capsularis* in China (Niu et al. 2016b): as no accurate dried type specimen was listed, this species has not been recognised as a reliable species. Another example is provided by *Colletotrichum jasmiginum*: the *cal*, *gs*, *tub2* and ITS sequences for the type strain of this species place it in the truncatum complex (no differences to *C. truncatum*)

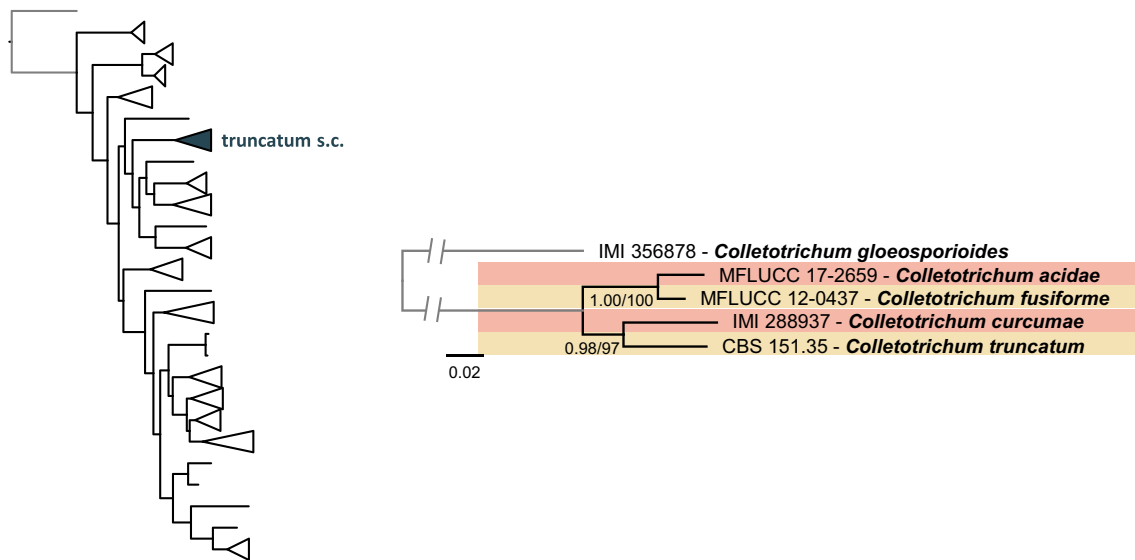

Fig. 17 Bayesian inference phylogenetic tree of the truncatum species complex. The tree was reconstructed from a combined multi-locus sequence alignment (ITS, *gapdh*, *chs-1*, *act* and *tub2*). For each locus the alignment was performed with MAFFT v7.450 (Kato and Standley 2013), exported to MEGA7 (Kumar et al. 2016) and the best-fit substitution model calculated. Phylogenetic analyses were performed with FastTree2 v2.1.10 (Price et al. 2010) and MrBayes 3.2.6 (Ron-

quist et al. 2012). Bayesian posterior probability (BPP) and Maximum-Likelihood (ML) bootstrap values (above 0.50) are reported next to the node; thicker branches represent node with BPP=1.00 and ML=100. The scale bar represents the number of expected substitutions per site. GenBank accession numbers are listed in Supplementary file 1

but the *act* and *gapdh* sequences place it in the gloeosporioides complex, suggesting that this species (containing a single isolate) is an artifact and does not exist (as detailed in “Geographical distribution of *Colletotrichum* occurrences” section). Overall members of this complex have been associated with 56 species belonging to 48 genera (23% monocots and 77% eudicots). Interestingly two different species of this clade have been reported as opportunistic human pathogens, *C. truncatum* and *C. fusiforme*.

Colletotrichum acidae Samarak. and K.D. Hyde, *Mycosphere* **9**: 587 (2018)

The single isolate belonging to *Colletotrichum acidae* was obtained from a dead rachis of *Phyllanthus acidus* (Phyllanthaceae) in Thailand in 2017 and treated as saprobe (Samarakoon et al. 2018), although there are no studies on putative pathogenicity to its host. The host plant, gooseberry tree, is widely cultivated as a fruit tree in the tropics. The abundance, pathological relevance and conservation status of this species remains to be investigated.

Colletotrichum curcuma (Syd. and P. Syd.) E.J. Butler and Bisby, *Fungi of India*: 153 (1931)

The species *Colletotrichum curcuma* was designated based on two isolates collected from *Curcuma longa* (Zingiberaceae) in India in 1912 and 1984 (Damm et al. 2009). More recently, in 2012, the fungus was identified as the causal agent of leaf spot symptoms on *Curcuma wenyujin* in China (Li et al. 2016d). There seems to be a biunivocal relationship between *Colletotrichum curcuma* and *Curcuma*.

Colletotrichum fusiforme Jayawardena, Bhat, Tangthirasun and K.D. Hyde, *Fungal Divers.* **75**: 158 (2015)

Colletotrichum fusiforme is known from a single isolate collected in Thailand in 2012 on a dead leaf of an unknown plant (Ariyawansa et al. 2015). Hung et al. (2020) reported fungi associated with human eye keratitis similar to *C. fusiforme*, treating these as genetics variants of *C. fusiforme* or putatively as new species. Under this scenario, the conservation status of *C. fusiforme* is of great concern.

Colletotrichum truncatum (Schwein.) Andrus and W.D. Moore, *Phytopathology* **25**: 121 (1935)

Colletotrichum truncatum is most noticed as causing anthracnose of economical relevance on Fabaceae and Solanaceae (Damm et al. 2009). In the past decade, the fungus was recorded from: the Amaranthaceae *Salsola komarovii* (Sato et al. 2015); the Amaryllidaceae *Allium*

angulosum and *A. fistulosum* (Matos et al. 2017; Salunkhe et al. 2018b), *Hippeastrum × hybridum* (Sato et al. 2015) and *Hymenocallis* sp. (Hyde et al. 2018); the Apocynaceae *Mandevilla* sp. (Watanabe et al. 2016) and *Plumeria rubra* (Sato et al. 2015); the Araceae *Alocasia macrorrhizos* (Ben et al. 2020), *Dieffenbachia* sp. and *Syngonium* sp. (Sato et al. 2015); the Asparagaceae *Dracaena braunii* (Liu et al. 2019b), *Polianthes tuberosa* (Mahadevakumar et al. 2019) and *Sansevieria* sp. (Sato et al. 2015); the Asteraceae *Dendranthema grandiflorum* (Sato et al. 2015), *Helianthus annuus* and *Xanthium strumarium* (as *X. occidentale*) (Shivas et al. 2016); the Basellaceae *Basella alba* (Yang et al. 2018); the Begoniaceae *Begonia × semperflorans* (Zhai et al. 2018); the Brassicaceae *Brassica rapa* (as *B. parachinensis*) and *B. rapa* var. *chinensis* (Sato et al. 2015; He et al. 2016); the Cactaceae *Hylocereus undatus* (Guo et al. 2014b; Sato et al. 2015; Ngoc et al. 2018); the Caricaceae *Carica papaya* (Sato et al. 2015; Aktaruzza-man et al. 2018; Vieira et al. 2020); the Chenopodiaceae *Chenopodium quinoa* (Pal and Testen 2021); the Cucurbitaceae *Cucumis sativus* (Sato et al. 2015); the Euphorbiaceae *Euphorbia pulcherrima* (Sato et al. 2015), *Jatropha curcas* (Ellison et al. 2015) and *Manihot esculenta* (Hyde et al. 2018; Machado et al. 2021b); the Fabaceae *Arachis hypogaea* (Damm et al. 2009; Shivas et al. 2016; Yu et al. 2020), *Cicer arietinum* (Mahmodi et al. 2013), *Glycine max* (Sato et al. 2015; Shivas et al. 2016; Rogério et al. 2019; Zaw et al. 2020), *Stylosanthes hamata* (Shivas et al. 2016; Hyde et al. 2018) and *Vigna subterranea* and *V. unguiculata* ssp. *sesquipedalis* (Sato et al. 2015; Hyde et al. 2018); the Malvaceae *Abutilon theophrasti* (Cong et al. 2020) and *Gossypium* sp. (Hyde et al. 2018); the Oleaceae *Fraxinus excelsior* (Davydenko et al. 2013); the Passifloraceae *Passiflora edulis* (Sato et al. 2015; Chen and Huang 2018); the Piperaceae *Piper betle* (Sun et al. 2020b); the Polygonaceae *Fagopyrum esculentum* (Sato et al. 2015); the Rosaceae *Fragaria × ananassa* (Sato et al. 2015; Bi et al. 2017a) and *Prunus persica* (Grabke et al. 2014); the Rutaceae *Citrus flamea*, *C. limon* and *C. reticulata* (Huang et al. 2013; Cheng et al. 2014; Guarnaccia et al. 2017); the Saururaceae *Houttuynia cordata* (Sato et al. 2015); the Solanaceae *Capsicum annum* and *C. frutescens* (Damm et al. 2009; Sato et al. 2015; Liu et al. 2016c; Diao et al. 2017; De Silva et al. 2017a; Tariq et al. 2017; Oo and Oh 2020) and *Solanum lycopersicum* and *S. melogena* (Diao et al. 2014; Sato et al. 2015; Saini et al. 2017b; Hyde et al. 2018; Almaraz-Sánchez et al. 2019); the Theaceae *Camellia sinensis* (Wang et al. 2016); the Violaceae *Viola odorata* (Katoch et al. 2017); the Vitaceae *Vitis labruscana × V. vinifera* (Zhang et al. 2018c); human eye (Valenzuela-Lopez et al. 2018). *Colletotrichum truncatum* is thus a polyphagous and cosmopolitan fungus,

with the most part of recent records being reported from Asia (Supplementary data 15).

Singleton species

Another 14 species of *Colletotrichum* do not cluster with any other species or species complexes and are therefore considered as singleton species.

Colletotrichum bambusicola C.L. Hou & Q.T. Wang, *Mycologia* **113**: 450-458 (2021)

The species *Colletotrichum bambusicola* was described based on fungi identified as endophytes on seeds of the bamboos *Brachystachyum densiflorum*, *Phyllostachys aureosulcata*, *Ph. edulis* and *Ph. sulphurea* on several locations in China (Wang et al. 2021b). Considering the endophytic nature of these fungi and the large number of species of *Colletotrichum* on bamboos, the conservation status of this species should be under surveillance.

Colletotrichum chlorophyti S. Chandra and Tandon, *Curr. Sci.* **34**: 565 (1965)

Colletotrichum chlorophyti is known from *Chlorophytum* sp. (Asparagaceae) in India, *Stylosanthes hamata* (Fabaceae) in Australia (Damm et al. 2009), soybean (*Glycine max*; Fabaceae) in the USA (Yang et al. 2012a), *Moringa oleifera* (Moringaceae) and *Atractylodes lancea* (as *A. chinensis*, Asteraceae) in China (Cai et al. 2016b; Sun et al. 2019a). *Colletotrichum chlorophyti* was also recently identified from a human eye associated to keratomycosis (Paniz-Mondolfi et al. 2021). *Colletotrichum chlorophyti* is thus a polyphagous and pluricontinental fungus (Supplementary data 16, panel A), but its ecological status and pathological relevance must be further clarified.

Colletotrichum citrus-medicae Qian Zhang, Yong Wang bis, Jayawardena & K.D. Hyde, in Hyde et al., *Fungal Divers.* **103**: 219-271 (2020)

Colletotrichum citrus-medicae was recently described based on isolates collected at a single location in China, associated to spots on *Citrus medica* leaves (Hyde et al. 2020c). The vast number of species of *Colletotrichum* occurring on citrus calls for attention concerning the conservation status of *C. citrus-medicae*.

Colletotrichum coccodes (Wallr.) S. Hughes, *Can. J. Bot.* **36**: 754 (1958)

Recorded from numerous hosts in diverse families, *C. coccodes* is most noticeable as a pathogen of *Solanum tuberosum* and *S. lycopersicum*, causing potato black dot and tomato anthracnose (Liu et al. 2011). Recent notices from different regions indicate its widespread presence worldwide (Çakır et al. 2019; Pérez-Mora et al. 2020) (Supplementary data 16, panel B).

Colletotrichum guangxiense C.L. Hou & Q.T. Wang, *Mycologia* **113**: 450-458 (2021)

The species *Colletotrichum guangxiense* was described based on fungi identified as endophytes on seeds of the bamboo *Phyllostachys edulis* in China (Wang et al. 2021b). Considering the endophytic nature of this fungus and the large number of species of *Colletotrichum* on bamboos, the conservation status of this species should be under surveillance.

Colletotrichum hsienjenchang I. Hino and Hidaka, *Bull. Miyazaki Coll. Agric. Forest.* **6**: 93-99 (1934)

This species is associated to bamboos (*Phyllostachys* spp., Poaceae) and recorded from Japan and China since 1934, with the most recent record dating from 2011 (Sato et al. 2012). The species is considered rare, although no other species of *Colletotrichum* are recorded from *Phyllostachys*, prompting further studies on these hosts to ascertain the current distribution and conservation status of *C. hsienjenchang*.

Colletotrichum metake Sacc., *Annls Mycol.* **6**: 557 (1908)

Colletotrichum metake was described as a fungus inhabiting an unspecified bamboo species in Italy in 1908 and is currently found on the Poaceae *Pleioblastus simonii* in Japan (Sato et al. 2012) and *Chimonobambusa quadrangularis* in China (Wang et al. 2021b). The species is considered rare (Sato et al. 2012) and further surveys are important to ascertain its conservation status in the future.

Colletotrichum nigrum Ellis and Halst., in Halsted, *New Jersey Agric. Coll. Exp. Sta. Bull.*: 297 (1895)

Colletotrichum nigrum was described as a pathogen of chilli (*Capsicum annuum*, Solanaceae) and subsequently reported from chicory (*Cichorium intybus*, Asteraceae), strawberry

(*Fragaria* × *ananassa*, Rosaceae), sunflower (*Helianthus tuberosus*, Asteraceae), lentil (*Lens culinaris*, Fabaceae) and tomato (*Solanum lycopersicum*, Solanaceae) in different parts of the world (Rivera et al. 2016) (Supplementary data 16, panel C). Several other species of *Colletotrichum* have been identified as causal agents of anthracnose on each of these hosts (and no reports on chicory) in recent years, whereas recent reports of *C. nigrum* are quite seldom: it was reported associated to tomato anthracnose in the USA in 2013 (Rivera et al. 2016), to autumn sage (*Salvia greggii*, Lamiaceae) in Italy in 2015 (Guarnaccia et al. 2019) and to quinoa (*Chenopodium quinoa*, Chenopodiaceae) in the USA in 2019 (Pal and Testen 2021). The current pathological relevance of *Colletotrichum nigrum* is uncertain and its conservation status is of concern.

Colletotrichum orchidophilum Damm, P.F. Cannon and Crous, *Stud. Mycol.* **73**: 83 (2012)

Colletotrichum orchidophilum was described from fungi isolated from the Orchidaceae × *Ascocenda* sp. in the USA, *Cycnoches aureum* in Panama, *Dendrobium* sp. in Thailand and the USA and *Phalaenopsis* sp. in the UK (Damm et al. 2012a; Ma et al. 2018). Such seldom reports, along with the large number of species of *Colletotrichum* occurring on orchids, raise concern on the conservation status of *C. orchidophilum*.

Colletotrichum pseudoacutatum Damm, P.F. Cannon and Crous, *Stud. Mycol.* **73**: 91 (2012)

The species *Colletotrichum pseudoacutatum* was described based on a single isolate, obtained from *Pinus radiata* (Pinaceae) in Chile in 1976 (Damm et al. 2012a). Recently the

species was rediscovered associated to anthracnose of *Syzygium jambos* (Myrtaceae) in Brazil (Soares et al. 2017). In spite of the seldom records, this recent finding suggests that the species may be currently occurring in nature at least in South America, but further studies are needed to account for its pathological relevance, geographic distribution and conservation status.

Colletotrichum pyrifoliae M. Fu and G.P. Wang, *Persoonia* **42**: 25 (2019)

Colletotrichum pyrifoliae is known only from a single isolate collected from *Pyrus pyrifolia* (Rosaceae) in China in 2016 (Fu et al. 2019). The absence of additional records for this fungus and the large number of species of *Colletotrichum* known from *Pyrus* raise high concern on the conservation status of *C. pyrifoliae*.

Colletotrichum rusci Damm, P.F. Cannon and Crous, *Fungal Divers.* **39**: 72 (2009)

Colletotrichum rusci was described based on a single isolate obtained from an unspecified species of *Ruscus* (Asparagaceae) in Italy in 2002 (Damm et al. 2009). No other species of *Colletotrichum* have been reported from *Ruscus*. The absence of any further occurrences of *C. rusci* raises severe concerns about its conservation status.

Colletotrichum sydowii Damm, *Stud. Mycol.* **86**: 99 (2017)

Colletotrichum sydowii is known from a single isolate obtained from an unspecified species of *Sambucus* (Adoxaceae) in China in 2011 (Marín-Felix et al. 2017). The absence of any further records for this fungus and the

Table 1 Species of *Colletotrichum* created since 2009 that have been subsequently synonymized

Original species	Year	Current species	References
<i>C. aciculare</i> Jayaward., Tangthir. and K.D. Hyde	2015	<i>C. truncatum</i>	Jayawardena et al. (2016a)
<i>C. aracearum</i> L.W. Hou and L. Cai	2016	<i>C. orchidearum</i>	Damm et al. (2019)
<i>C. citri</i> F. Huang, L. Cai, K.D. Hyde and Hong Y. Li	2013	<i>C. nymphaeae</i>	Damm et al. (2020)
<i>C. clavatum</i> Agosteo, Faedda and Cacciola	2011	<i>C. godetiae</i>	Damm et al. (2012a)
<i>C. cliviae</i> Yan L. Yang, Zuo Y. Liu, K.D. Hyde and L. Cai	2009	<i>C. cliviicola</i>	Damm et al. (2019)
<i>C. communis</i> G. Sharma, Pinnaka and Shenoy	2014	<i>C. siamense</i>	Sharma et al. (2015)
<i>C. dianesei</i> N.B. Lima, M.P.S. Câmara and Michereff	2013	<i>C. siamense</i>	Sharma et al. (2015)
<i>C. endomangiferae</i> W.A.S. Vieira, M.P.S. Câmara and Michereff	2014	<i>C. siamense</i>	Sharma et al. (2015)
<i>C. hymenocallidicola</i> Chethana, Tangthir., Wijayaw. and K.D. Hyde	2015	<i>C. orchidearum</i>	Damm et al. (2019)
<i>C. hymenocallidis</i> Yan L. Yang, Zuo Y. Liu, K.D. Hyde and L. Cai	2009	<i>C. siamense</i>	Liu et al. (2015a)
<i>C. ignotum</i> E.I. Rojas, S.A. Rehner and Samuels	2010	<i>C. fructicola</i>	Weir et al. (2012)
<i>C. jasmini-sambac</i> Wikee, K.D. Hyde, L. Cai and McKenzie	2011	<i>C. siamense</i>	Liu et al. (2015a)
<i>C. melanocaulon</i> V.P. Doyle, P.V. Oudem. and S.A. Rehner	2013	<i>C. siamense</i>	Sharma et al. (2015)
<i>C. murrayae</i> Li J. Peng and K.D. Hyde	2012	<i>C. siamense</i>	Sharma et al. (2015)
<i>C. populi</i> C.M. Tian & Zheng Li	2012	<i>C. aenigma</i>	Liu et al. (2013a)
<i>C. thailandicum</i> Phouliv., Noireung, L. Cai and K.D. Hyde	2012	<i>C. gigasporum</i>	Liu et al. (2014)

occurrence of other species of *Colletotrichum* on *Sambucus* raises serious concerns on the conservation status of *C. sydowii*.

Colletotrichum trichellum (Fr.) Duke, *Trans. Br. Mycol. Soc.* **13**: 173 (1928)

Colletotrichum trichellum is a pathogen of ivy (*Hedera* spp., Araliaceae), reported from diverse parts of the world (Damm et al. 2009; Sato et al. 2015) (Supplementary data 16, panel D), although still lacking modern taxonomic treatment (Damm et al. 2009; Cannon et al. 2012). Recent records are scarce, suggesting that the conservation status of *C. trichellum* should be better monitored.

Synonymised and doubtful species of *Colletotrichum*

From the 805 species of *Colletotrichum* recorded in Index Fungorum, the present work lists 257 species, meaning that another 548 species are pending modern treatment or have been synonymised. Table 1 lists the species described since 2009 that are not in use as they have been subsequently synonymised.

Additionally, the taxon *Colletotrichum japonicum* (Hemmi) Bedlan was named to accommodate a pathogen of *Berberis aquifolium* occurring in Japan (Bedlan 2012) and presumably also in Poland and Austria (Świdarska-Burek

2021), but no molecular data is provided, and the taxon is pending modern taxonomic treatment.

Also, *Colletotrichum jasminigenum*, known from a single record obtained from *Jasminum sambac* (Oleaceae) in Vietnam in 2009 (Wikee et al. 2011) and placed in the truncatum complex, was described based on ITS, *tub2*, *cal* and *gs* sequences (HM131513, HM153770, HM131494 and HM131504 GenBank references, respectively) that are similar to those of *C. truncatum*, whereas the *act* and *gapdh* sequences (HM131508 and HM131499, respectively) are similar to those of *C. pandanicola* (gloeosporioides complex), suggesting that *C. jasminigenum* is an artifact and that it should not be recognised as a species.

Similarly, *Colletotrichum Chiangraiense* reported once, from a *Dendrobium* sp. (Orchidaceae) root in Thailand in 2013 (Ma et al. 2018), along with other *Colletotrichum* species and placed by the authors in the boninense complex, is considered as an artifact, since the ITS sequence of the type strain (MF448522) places this taxon in the boninense complex, whereas the *act* (MH376383) and *tub2* (MH351275) sequences place it in the gigasporum complex.

Geographical distribution of *Colletotrichum* occurrences

In this work we documented 2717 occurrences of *Colletotrichum*, with 25.6% of the records in China, followed by Brazil (9.4%), Australia (8.5%) and the USA (8.1%), and

Table 2 Number of occurrences of *Colletotrichum* spp. (for species with 30 or more records in this work) per continent

Species	N.C. America	S. America	Africa	Europe	Asia	Oceania	Total
<i>C. siamense</i>	20	38	6	0	144	25	228
<i>C. gloeosporioides</i>	10	17	6	54	110	20	217
<i>C. fructicola</i>	11	37	2	8	113	6	176
<i>C. fioriniae</i>	43	1	1	33	36	22	134
<i>C. truncatum</i>	5	4	2	2	110	7	130
<i>C. karstii</i>	16	24	6	19	48	19	130
<i>C. nymphaeae</i>	15	26	8	39	28	6	118
<i>C. acutatum</i>	0	10	15	19	4	28	68
<i>C. godetiae</i>	5	3	1	51	3	2	65
<i>C. theobromicola</i>	12	27	0	0	5	13	56
<i>C. tropicale</i>	9	26	0	0	13	0	48
<i>C. lupini</i>	5	1	4	17	2	16	45
<i>C. scovillei</i>	1	5	0	0	36	0	42
<i>C. simmondsii</i>	2	0	0	2	2	34	40
<i>C. brevisporum</i>	2	12	0	0	22	4	40
<i>C. asianum</i>	3	8	3	0	11	9	34
<i>C. coccodes</i>	7	1	2	13	4	4	31
Total (incl. other spp.)	335	353	98	420	1144	347	2697

Heatmaps (green—low; red—high) depict the relative frequency of occurrence of each species per continent

Table 3 The ten species of *Colletotrichum* with the larger number of host species

Species	Complex	nr host species
<i>C. siamense</i>	gloeosporioides	103
<i>C. gloeosporioides</i>	gloeosporioides	87
<i>C. fioriniae</i>	acutatum	73
<i>C. karsti</i>	boninense	63
<i>C. fructicola</i>	gloeosporioides	63
<i>C. truncatum</i>	truncatum	52
<i>C. nymphaeae</i>	acutatum	42
<i>C. acutatum</i>	acutatum	40
<i>C. theobromicola</i>	gloeosporioides	31
<i>C. tropicale</i>	gloeosporioides	31

Follow *C. godetiae*, *C. spaethianum*, *C. cigarro*, *C. aenigma*, *C. boninense* and *C. simmondsii*

then by Italy, Japan, and New Zealand (4–5% each), followed by Thailand, India and the Netherlands. By continent, Asia represents 42.1% of the occurrences, followed by America (25.0%), Europe (15.6%), Oceania (12.9%) and Africa (3.6%). However, species of *Colletotrichum* are distributed differently, for example, *C. acutatum*, *C. simmondsii* and *C. queenslandicum* preferentially occur in Australia and *C. aotearoa* in New Zealand; *C. kahawae* is restricted to Africa; *C. abscissum*, *C. chrysophilum*, *C. fructivorum*, *C. tamarilloi*, *C. theobromicola* and *C. tropicale* occur mostly in America; *C. godetiae* (and to a certain extent, *C. fioriniae* and *C. nymphaeae*) occur more frequently in Europe (Table 2).

Host specificity

Colletotrichum occurs mostly on dicotyledonous plants (over 77% of all host-fungus species association records), but monocotyledonous hosts are the most common in the clade grouping the caudatum, graminicola and spaethianum species complexes. *Colletotrichum* also occurs, although less frequently, on gymnosperms, ferns, mosses and animals.

In this work we have recorded 1358 unique host species-*Colletotrichum* species association records from 720 hosts (Supplementary data 1, ‘occurrences’ tab). Two members of the gloeosporioides complex, such as *Colletotrichum siamense* and *C. gloeosporioides* are the species with the largest number of host species (Table 3), inhabiting hosts from very diverse botanical families. On the other hand, several species consistently present a high degree of host specificity. These include: in the acutatum complex, *Colletotrichum abscissum* on *Citrus sinensis*, *Colletotrichum laticipulum* on *Hevea brasiliensis*, *C. lupini* on *Lupinus* spp., *C. phormii* on *Phormium* spp. and *C. tamarilloi* on *Solanum betaceum*; in the agaves complex, *C. agaves* on *Agave* spp. and *C. sansevieriae* on *Sansevieria trifasciata*; in the boninense complex, *C. petchii* on *Dracaena* spp.; in the destructivum complex, *C. lentis* on *Lens culinaris*, *C. ocimi* on *Ocimum basilicum* and *C. pisicola* on *Pisum sativum*; in the dracaenophilum complex, *C. dracaenophilum* on *Dracaena* spp.; in the gloeosporioides complex, *C. alatae* on *Dioscorea alata*, *C. arecicola* on *Areca catechu*, *C. camelliae* on *Camellia* spp., *Colletotrichum horii* on *Diospyros kaki*, *C. kahawae* on *Coffea arabica*, *Colletotrichum musae* on *Musa* spp. and *C. perseae* on *Persea americana*; in the graminicola complex, *C. eremochloae* on *Eremochloa ophiuroides*, *C. falcatum* on *Saccharum*

Table 4 Number of *Colletotrichum* species-host species combinations by complex

Complex	nr species	nr <i>Colletotrichum</i> species-host combinations	Combinations/ <i>Colletotrichum</i> species ratio
acutatum	41	295	7.2
agaves	5	8	1.6
boninense	26	129	5.0
caudatum	8	9	1.1
dematium	17	37	2.2
destructivum	20	57	2.9
dracaenophilum	8	10	1.3
gigasporum	8	15	1.9
gloeosporioides	57	516	9.1
graminicola	16	31	2.0
magnum	8	30	3.8
orbiculare	8	20	2.5
orchidearum	8	41	5.1
spaethianum	9	52	5.8
truncatum	4	58	14.5

Table 5 Number of host species, of fungus-host combinations and number of *Colletotrichum* species and species complexes by host family

Family	nr host species	nr <i>Colletotrichum</i> species-host combinations	nr species complexes	nr <i>Colletotrichum</i> species
Rosaceae	33	118	7	41
Fabaceae	51	87	11	36
Solanaceae	14	72	10	41
Rutaceae	24	63	7	31
Orchidaceae	28	59	9	36
Poaceae	42	53	5	32
Anacardiaceae	8	42	6	23
Asparagaceae	32	42	8	20
Theaceae	6	33	5	20
Proteaceae	17	33	4	15
Myrtaceae	16	32	3	23
Asteraceae	26	30	9	22
Malvaceae	14	30	8	18
Euphorbiaceae	11	28	6	19
Rubiaceae	6	27	6	22
Amaryllidaceae	12	26	6	17
Lauraceae	6	23	3	19
Oleaceae	8	22	4	17
Ericaceae	7	19	3	11
Vitaceae	6	18	4	14
Lamiaceae	12	17	4	13
Moraceae	8	15	5	10
Musaceae	5	14	3	10
Arecaceae	5	13	3	10
Caricaceae	1	12	6	12
Apiaceae	6	12	6	12

Only families inhabited by 10 or more species of *Colletotrichum* are listed; the Araceae (11 host species and 18 fungus-host associations), the Cucurbitaceae (nine host species and 16 fungus-host associations) and the Annonaceae (five host species and 15 fungus-host associations) follow

officinatum, *C. graminicola* on *Zea mays* and *C. sublineola* on *Sorghum* spp.; in the orbiculare complex, *C. lindemuthianum* on *Phaseolus* spp.; *Colletotrichum trichellum* (singleton species) on *Hedera* spp. Many other examples are pending further records to confirm the host specificity of such fungi. Whereas some *Colletotrichum* species are specific of a given host species (e.g., *C. tamarilloi* or *C. laticiphilum*), others are specific of the host genus (e.g., *C. lupini* or *C. camelliae*) and others are specific at

the family level, such as: in the acutatum complex, *C. carthami* and *C. chrysanthemi* on the Asteraceae; in the boninense complex, *C. cymbidiicola* on the Orchidaceae; in the graminicola complex, *C. cereale* on the Poaceae; in the orbiculare complex, *C. orbiculare* on the Cucurbitaceae; in the orchidearum complex, *C. sojae* on the Fabaceae; *C. orchidophilum* (singleton species) on the Orchidaceae.

Table 6 Number of unique association records between *Colletotrichum* species and host families per species complex and for the most represented families

Host family	Species complex														Total	
	sin- gleton species	acutatum	agaves	bonin- ense	cauda- tum	dema- tium	destructi- vum	dracae- nophi- lum	gigaspo- rum	gloe- ospori- oides	gramini- cola	magnum	orbicu- lare	orchide- arum		spaethi- anum
Dicots																
Anacardi- aceae	0	6	0	1	0	0	0	0	1	13	0	1	0	1	0	23
Apiaceae	0	2	0	0	0	4	3	0	1	1	0	0	0	0	1	12
Asteraceae	2	3	0	1	0	2	5	0	0	3	0	0	2	1	2	22
Caricaceae	0	2	0	1	0	0	0	0	0	4	0	3	0	1	0	12
Ericaceae	0	4	0	1	0	0	0	0	0	6	0	0	0	0	0	11
Euphorbi- aceae	0	7	1	3	0	0	0	0	0	6	0	0	0	1	0	19
Fabaceae	3	6	0	1	0	2	7	0	1	4	0	1	2	4	4	36
Lamiaceae	2	1	0	0	0	1	5	0	0	4	0	0	0	0	0	13
Lauraceae	0	4	0	1	0	0	0	0	0	14	0	0	0	0	0	19
Malvaceae	0	1	0	1	0	0	0	0	1	7	0	1	4	2	0	18
Moraceae	0	1	0	1	0	0	0	0	0	6	0	1	0	1	0	10
Myrtaceae	1	8	0	4	0	0	0	0	0	10	0	0	0	0	0	23
Oleaceae	0	6	0	1	0	0	0	0	0	8	0	0	0	0	0	16
Proteaceae	0	6	0	2	0	0	0	0	0	6	0	0	0	0	1	15
Rosaceae	4	15	0	4	0	2	1	0	0	13	0	0	0	1	0	41
Rubiaceae	0	4	0	3	0	0	0	0	2	11	0	1	0	1	0	22
Rutaceae	1	8	0	7	0	0	0	1	0	11	0	1	0	1	0	31
Solan- aceae	2	12	0	5	0	1	1	0	0	13	0	2	1	2	1	41
Theaceae	0	4	0	4	0	0	0	0	1	10	0	0	0	0	1	20
Vitaceae	0	3	0	0	0	3	0	0	0	7	0	0	0	0	1	14
Others (dicots)	7	60	0	20	0	14	14	2	2	107	0	8	2	4	5	258
Monocots																
Amarylli- daceae	1	5	0	3	0	1	0	0	0	3	0	0	0	2	1	17
Araceae	0	0	0	1	0	0	0	0	1	1	0	1	0	4	0	9
Areaceae	0	1	0	1	0	0	0	0	0	7	0	0	0	0	0	10
Aspara- gaceae	2	0	4	2	0	1	0	1	0	5	0	0	1	0	3	20
Musaceae	0	2	0	1	0	0	0	0	0	7	0	0	0	0	0	10
Orchi- daceae	1	0	0	8	3	0	2	5	2	4	3	0	0	4	4	36

Table 6 (continued)

Host family	Species complex													Total			
	sin-gleton species	acutatum	agaves	boninense	caudatum	dematium	destructivum	dracaenophilum	gigasporum	gloeosporioides	graminicola	magnum	orbiculare		orchidearum	spaethianum	truncatum
Poaceae	5	0	0	1	5	0	2	0	0	4	14	0	0	1	0	0	37
Others (monocots)	1	6	0	3	0	1	0	0	0	18	0	2	0	0	9	2	42
Others																	
Gymnosperms	1	4	0	4	0	0	0	0	0	4	0	0	0	0	0	0	13
Others (mosses, ferns and animals)	1	3	0	0	0	1	1	0	0	6	1	0	0	0	0	2	15
Total	34	184	5	85	8	33	41	9	12	324	18	22	12	31	31	31	885

The gloeosporioides complex encompasses 516 *Colletotrichum* species-host species association records, followed by the acutatum and the boninense complexes (Table 4). The acutatum, gloeosporioides and truncatum complexes have, on average, over seven host species for each species of *Colletotrichum*, whereas the agaves, caudatum, dracaenophilum and graminicola have on average between one and two host species for each species of *Colletotrichum*. It is worth noting that most of the later complexes contain species more frequently found on monocots.

The Fabaceae is the family with the largest number of species hosting *Colletotrichum* (51 host species), followed by the Poaceae (42 hosts), and then by the Orchidaceae, Asparagaceae and Rosaceae (Table 5). Nevertheless, it is in the Rosaceae that the highest number of *Colletotrichum* species-host species association records is found (118), followed by the Fabaceae (87), Solanaceae (72), Rutaceae (63) and Orchidaceae (59). The Fabaceae stand out also as the family hosting the highest number of species complexes (11), followed by the Solanaceae (10) and the Asteraceae and Orchidaceae (9 each).

The Rosaceae and the Solanaceae host 41 species of *Colletotrichum* each, followed by the Orchidaceae and the Fabaceae (36 species), and then by the Poaceae and Rutaceae (Table 6). There are 880 unique association records between *Colletotrichum* species and host family, with the gloeosporioides complex representing 36.8% of such association records, followed by the acutatum complex (20.9%) and by the boninense complex (9.7%), and then by the destructivum, truncatum, spaethianum, orchidearum and dematium complexes (3–5% each). Whereas for most host families these proportions remain valid (e.g., the Anacardiaceae, Ericaceae, Lauraceae, Malvaceae, Moraceae, Myrtaceae, Oleaceae, Proteaceae, Rosaceae, Rubiaceae, Rutaceae, Solanaceae, Theaceae and Vitaceae, i.e., mostly dicots, but also the Arecaceae and Musaceae), some other families clearly have different patterns of preference concerning species complexes. The destructivum complex registers the highest number of unique species-host family association records in the Fabaceae, Asteraceae and Lamiaceae, instead of the gloeosporioides complex, whereas the destructivum and dematium complexes are the most represented in the Apiaceae. In the Euphorbiaceae, the acutatum complex is more represented than the gloeosporioides one. The situation is more heterogeneous among the monocots: the graminicola complex (followed by the caudatum complex) prevails in the Poaceae; the boninense complex is the most common in the Orchidaceae, and along with gloeosporioides in the Amaryllidaceae and with orchidearum in the Araceae; the agaves complex (along with gloeosporioides and spaethianum) is the most represented in the Asparagaceae. Although supported on limited numbers, the acutatum and boninense

complexes are more frequent on the gymnosperms than the gloeosporioides complex.

Abundance and conservation of *Colletotrichum* spp.

Colletotrichum occur on a large number of host and locations, with new host and locations frequently reported. Over the last decade, *Colletotrichum* became consolidated as the second most referred genus in terms of number of Plant Disease Notes published in the journal Plant Disease, raising from an average of 17.7 Notes per year during 2010–2015 to 48 Notes per year during 2016–2020, second only to *Fusarium* (Fig. 18).

As discussed in the previous sections, several species of *Colletotrichum* occur on multiple hosts and in diverse locations, whereas others are host specific and/or geographically confined, but still are common on those hosts and/or regions. Being mostly plant pathogens, some of these fungi cause losses of economical relevance on agricultural crops, thus requiring control. Other species however are uncommon or even rare, and may incur in conservation problems. From the 257 species of *Colletotrichum* listed in this work, 101 (i.e., 39.3% of all species) have been recorded only once and another 44 have been recorded only twice, meaning that only 44.0% of the 257 species recognised have been recorded three times or more. In fact, the 10% more common species represent 67.2% of all occurrences.

Many of these unfrequent species have been recorded recently and it is therefore plausible that additional

occurrences arise in the future. Until then, however, such species must be regarded as potentially endangered. The number of occurrences and year of description of recent but unfrequent species are presented in Table 7. For instance, *Colletotrichum yunnanense* was described in 2007 based on one occurrence but never recorded again and *C. fructivorum*, although recorded nine times, was never again documented besides its original description in 2013.

In this work we have considered 88 species as common, meaning that the remaining 169 species are of seldom occurrence. Among these, we have considered 42 species as threatened, either because they have not been recorded in spite of recurrent surveys or because they are rare and have been described in circumstances that impair conducting additional surveys. The list of the 42 species considered as threatened is presented in Table 8, arranged by species complexes and containing information related to each species.

Another 127 species are treated as ‘data deficient’ (Table 9) and further surveys are needed to ascertain their conservation status, host range and geographic distribution, including unfrequent species that have been recently described along with others not recorded for decades but from hosts not commonly surveyed.

Altogether, from the 257 species of *Colletotrichum*, 127 are classified as ‘data deficient’ and 42 as ‘threatened’, meaning that 169 species (65.8% of total) are not known to be firmly established in nature. The remaining 88 species are considered ‘common’ and generally occur on multiple hosts or in single hosts but in multiple locations. The relative proportion of these three categories varies according to the species complex, with threatened species representing a large fraction of the species in the orchidearum and gigasporum

Fig. 18 Number of Plant Disease Notes published in the journal Plant Disease (section “Diseases Caused by Fungi and Fungus-Like Organisms”) for the five most reported genera, by year of publication

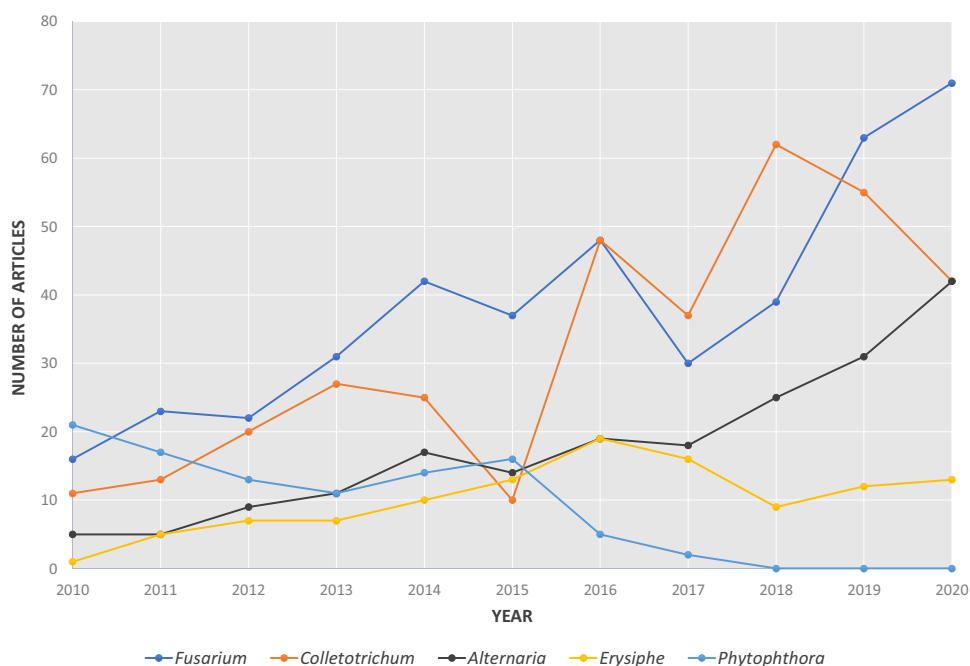

Table 7 Number of species of *Colletotrichum* recently described but seldomly reported, according to year of publication of the taxon and to the number of occurrences recorded in this work

Year	Number of occurrences								
	1	2	3	4	5	6	7	8	9
2021	5	1		1				1	
2020	6	4		1			1		
2019	10		1						
2018	17	2	4						
2017	10	3	1	1					
2016	7	2	1	1					
2015	3	2	2						
2014	3	2	1						
2013	8	5	1	1					1
2012	8	5	4			2			
2011	1						1		
2010									
2009	2								
2008									
2007	1								

Table 8 List of 42 species of *Colletotrichum* considered as threatened

Species	Notes	References
Singleton species		
<i>C. rusci</i>	Endangered (one record only), from <i>Ruscus</i> sp.	Damm et al. (2009)
<i>C. sydowii</i>	Highly endangered (one record only) and other species occur on the same host (<i>Sambucus</i> sp.)	Marín-Felix et al. (2017)
Acutatum complex		
<i>C. acerbum</i>	Possibly extinct; detection only in 1987 from <i>Malus domestica</i> and other species occur on the same host and location (New Zealand)	Lardner et al. (1999) and Damm et al. (2012a)
<i>C. brisbanense</i>	Possibly extinct; single detection in 1955 from <i>Capsicum annuum</i> and many other species occur on the same host and location (Australia)	Damm et al. (2012a) and Shivas et al. (2016)
<i>C. cairnsense</i>	Highly endangered (one record only) and many other species occur on the same host (<i>Capsicum annuum</i>)	Silva et al. (2017a)
<i>C. costaricense</i>	Highly endangered (two records only), from <i>Coffea</i> sp.; last detection < 1978	Damm et al. (2012a)
<i>C. cuscutae</i>	Highly endangered (one record only), from <i>Cuscuta</i> sp.; single detection in 1986	Damm et al. (2012a)
<i>C. paxtonii</i>	Possibly extinct; single detection in 1972 from <i>Musa</i> sp. and other species occur on the same host	Damm et al. (2012a)
<i>C. walleri</i>	Highly endangered (one record only) and other species occur on the same host (<i>Coffea</i> sp.); single detection < 2012	Damm et al. (2012a)
<i>C. wanningense</i>	Highly endangered (one record only) and other species occur on the same host (<i>Hevea brasiliensis</i>)	Cao et al. (2019b)
Agaves complex		
<i>C. euphorbiae</i>	Critically endangered (one record only) and host plant (<i>Euphorbia</i> sp.) highly uncertain	Crous et al. (2013)
Boninense complex		
<i>C. camelliae-japonicae</i>	Highly endangered (one record only) and other species occur on the same host (<i>Camellia japonica</i>)	Hou et al. (2016)
<i>C. constrictum</i>	Highly endangered (two records only) and other species occur on the same hosts (<i>Citrus limon</i> and <i>Solanum betaceum</i>); last detection in 1988	Damm et al. (2012b)
<i>C. limonicola</i>	Highly endangered (one record only) and other species occur on the same host (<i>Citrus limon</i>)	Guarnaccia et al. (2017)
<i>C. novae-zelandiae</i>	Possibly extinct; known from <i>Capsicum annuum</i> and <i>Citrus × paradisi</i> ; last detection in 1990; other species occur on the same hosts	Johnston and Jones (1997) and Damm et al. (2012b)

Table 8 (continued)

Species	Notes	References
<i>C. oncidii</i>	Highly endangered (one record only) and other species occur on the same host (<i>Oncidium</i> sp.)	Damm et al. (2012b)
<i>C. watphraense</i>	Highly endangered (one record only) and other species occur on the same host (<i>Dendrobium</i> sp.)	Ma et al. (2018)
Dematium complex		
<i>C. fructi</i>	Possibly extinct; last detection in 1937 from <i>Malus domestica</i> and other species occur on the same host and location (USA)	González et al. (2006) and Damm et al. (2009)
<i>C. sedi</i>	Highly endangered (one record only) and other species occur on the same host (<i>Sedum</i> sp.)	Liu et al. (2015b)
<i>C. sonchicola</i>	Highly endangered (one record only), from <i>Sonchus</i> sp.	Jayawardena et al. (2017)
Destructivum complex		
<i>C. orchidis</i>	Highly endangered (one record only) and other species occur on the same host (<i>Orchis</i> sp.)	Hyde et al. (2020b)
<i>C. pisicola</i>	Possibly extinct; known from <i>Pisum sativum</i> ; last detection in 1997	Damm et al. (2014)
<i>C. pleopeltidis</i>	Endangered (one record only) and host plant (<i>Pleopeltis</i> sp.) uncertain	Crous et al. (2021)
<i>C. vignae</i>	Possibly extinct; single detection < 1997 and other species occur on the same host (<i>Vigna unguiculata</i>)	Damm et al. (2014)
Dracaenophilum complex		
<i>C. coelogyne</i>	Highly endangered (one record only) and other species occur on the same host (<i>Coelogyne</i> sp.)	Damm et al. (2019)
<i>C. parallelophorum</i>	Highly endangered (one record only) and other species occur on the same host (<i>Dendrobium harveyanum</i>)	Ma et al. (2018)
<i>C. yunnanense</i>	Highly endangered (one record only), from <i>Buxus</i> sp.	Damm et al. (2019)
Gigasporum complex		
<i>C. magnisporum</i>	Possibly extinct; single detection < 1984 from unknown substrate	Liu et al. (2014)
<i>C. pseudomajus</i>	Possibly extinct; single detection < 1988 and many other species occur on the same host (<i>Camellia sinensis</i>) and location (China)	Liu et al. (2014)
<i>C. radialis</i>	Possibly extinct; single detection in 1993 from root of an unknown plant	Liu et al. (2014)
<i>C. vietnamense</i>	Highly endangered (two records only) and other species occur on the same host (<i>Coffea</i> sp.)	Liu et al. (2014)
Gloeosporioides complex		
<i>C. grevilleae</i>	Highly endangered (one record only), from <i>Grevillea</i> sp.	Liu et al. (2013a)
<i>C. hebeiense</i>	Highly endangered (two records only) and other species occur on the same host (<i>Vitis vinifera</i>)	Yan et al. (2015)
<i>C. makassarensis</i>	Highly endangered (one record only) and other species occur on the same host (<i>Capsicum annuum</i>)	De Silva et al. (2019)
<i>C. pandanicola</i>	Highly endangered (one record only) and other species occur on the same host (<i>Pandanus</i> sp.)	Tibpromma et al. (2018)
<i>C. perseae</i>	rare, from <i>Persea americana</i>	Sharma et al. (2017)
<i>C. proteae</i>	Highly endangered (one record only) and same host plant (<i>Protea</i> sp.) uncertain	Liu et al. (2013a)
<i>C. psidii</i>	Possibly extinct; single detection < 1927 and other species occur on the same host (<i>Psidium</i> sp.)	Weir et al. (2012)
<i>C. tainanense</i>	Highly endangered (one record only) and other species occur on the same host (<i>Capsicum annuum</i>)	De Silva et al. (2019)
Orchidearum complex		
<i>C. cattleyicola</i>	Highly endangered (two records only) and other species occur on the same host (<i>Cattleya</i> sp.); last detection < 2000	Damm et al. (2019)
<i>C. piperis</i>	Possibly extinct; from <i>Piper</i> spp.; last detection < 1957	Damm et al. (2019)
<i>C. vittalense</i>	Possibly extinct, from <i>Theobroma cacao</i> and an unspecified Orchidaceae; last detection < 1928	Damm et al. (2019)
Truncatum complex		
<i>C. fusiforme</i>	Highly endangered (two records only), from an unknown plant and from human eye	Ariyawansa et al. (2015) and Hung et al. (2020)

Table 9 List of 127 species of *Colletotrichum* treated as ‘data deficient’

Species	Notes	References
Singleton species		
<i>C. citrus-medicae</i>	Highly endangered (one record only) and other species occur on the same host (<i>Citrus medica</i>)	Hyde et al. (2020c)
<i>C. guangxiense</i>	Highly endangered (two records only) and other species occur on the same host (<i>Phyllostachys edulis</i>)	Wang et al. (2021b)
<i>C. hainanense</i>	Few records and other species occur on the same host (<i>Axonopus compressus</i>)	Zhang et al. (2020c)
<i>C. hsienjenchang</i>	Rare, from <i>Phyllostachys</i> spp.	Sato et al. (2012)
<i>C. metake</i>	Rare, from <i>Phyllostachys</i> spp.	Sato et al. (2012) and Wang et al. (2021b)
<i>C. orchidophilum</i>	Seldom reports and other species occur on the same hosts (orchids)	Damm et al. (2012a)
<i>C. pseudoacutatum</i>	Rare, from <i>Pinus radiata</i> and <i>Syzygium jambos</i>	Damm et al. (2012a) and Soares et al. (2017)
<i>C. pyrifoliae</i>	Highly endangered (one record only) and other species occur on the same host (<i>Pyrus pyrifolia</i>)	Fu et al. (2019)
Acutatum complex		
<i>C. arboricola</i>	Recorded only from <i>Fuchsia magellanica</i> in Chile, with unprecise reference to putative additional occurrences	Crous et al. (2018a)
<i>C. australe</i>	Highly endangered (two records only), from <i>Trachycarpus fortunei</i> and <i>Hakea</i> sp.	Damm et al. (2012a)
<i>C. cosmi</i>	Highly endangered (one ancient record only), from <i>Cosmos</i> sp.	Damm et al. (2012a)
<i>C. indonesiense</i>	Highly endangered (one record only) and other species occur on the same host (<i>Eucalyptus</i> sp.)	Damm et al. (2012a)
<i>C. javanense</i>	Highly endangered (one record only) and other species occur on the same host (<i>Capsicum annuum</i>)	De Silva et al. (2019)
<i>C. johnstonii</i>	Highly endangered (two records) and other species occur on the same hosts (<i>Citrus</i> sp. and <i>Solanum lycopersicum</i>); last detection in 1990	Damm et al. (2012a)
<i>C. kinghornii</i>	Single detection in 1935 from <i>Phormium tenax</i> and other species occur on the same host	Damm et al. (2012a)
<i>C. kniphofiae</i>	Endangered (one record only), from <i>Kniphofia uvaria</i>	Crous et al. (2018b)
<i>C. lauri</i>	Highly endangered (one record only) and other species occur on the same host (<i>Laurus nobilis</i>)	Hyde et al. (2017)
<i>C. limetticola</i>	Seldom reports and other species occur on the same hosts (citrus and apple)	Damm et al. (2012a), Guarnaccia et al. (2017) and Moreira et al. (2019a)
<i>C. pyricola</i>	Rare, from <i>Daphne odora</i> , <i>Embothrium coccineum</i> and <i>Pyrus communis</i>	Damm et al. (2012a), Shivas et al. (2016) and Zapata and Opazo (2017)
<i>C. rhombiforme</i>	Rare, from <i>Malus domestica</i> , <i>Olea europaea</i> and <i>Vaccinium</i> spp.	Damm et al. (2012a), Wu et al. (2017) and Wang et al. (2019b)
<i>C. roseum</i>	Rare, from <i>Lapageria rosea</i>	Crous et al. (2019a)
<i>C. sloanei</i>	Highly endangered (two records only) and other species occur on the same hosts (<i>Theobroma cacao</i> and <i>Litchi chinensis</i>); last detection in 2003	Damm et al. (2012a) and Shivas et al. (2016)
Agaves complex		
<i>C. agaves</i>	Rare in recent years, from Agavaceae; most records from the early twentieth century, last detection in 2002	Farr et al. (2006)
<i>C. ledebouriae</i>	Endangered (one record only), from <i>Ledebouria flori-dunda</i>	Crous et al. (2016)
<i>C. neosansevieriae</i>	Highly endangered (one recent record only) and other species occur on the same host (<i>Sansevieria trifasciata</i>)	Crous et al. (2015)
Boninense complex		
<i>C. annellatum</i>	Highly endangered (one record only) and other species occur on the same host (<i>Hevea brasiliensis</i>)	Damm et al. (2012b)

Table 9 (continued)

Species	Notes	References
<i>C. beeveri</i>	Highly endangered (one record only), from <i>Brachyglottis repanda</i> , but may be present in other hosts	Damm et al. (2012b)
<i>C. brasiliense</i>	Highly endangered (one confirmed record only) and other species occur on the same host (<i>Passiflora edulis</i>)	Damm et al. (2012b)
<i>C. brassicicola</i>	Highly endangered (two records only) and other species occur on the same hosts (<i>Brassica oleracea</i> and <i>Rubus glaucus</i>)	Damm et al. (2012b) and Afanador-Kafuri et al. (2014)
<i>C. catinaense</i>	Endangered (two records only), from <i>Citrus</i> spp.	Guarnaccia et al. (2017)
<i>C. chongqingense</i>	Highly endangered (one record only) and other species occur on the same host (<i>Camellia sinensis</i>)	Wan et al. (2021)
<i>C. citricola</i>	Endangered (few records) and other species occur on the same hosts (<i>Citrus unchiu</i> , <i>Pyrus pyrifolia</i> and <i>Dendrobium</i> sp.)	Fu et al. (2019)
<i>C. colombiense</i>	Highly endangered (one confirmed record only) and other species occur on the same host (<i>Passiflora edulis</i>)	Damm et al. (2012b)
<i>C. condaoense</i>	Endangered (one record only), from <i>Ipomoea pes-caprae</i>	Crous et al. (2018c)
<i>C. dacrycarpi</i>	Highly endangered (one record only), from <i>Dacrycarpus dacrydioides</i>	Damm et al. (2012b)
<i>C. doitungense</i>	Highly endangered (one record only) and other species occur on the same host (<i>Dendrobium</i> sp.)	Ma et al. (2018)
<i>C. feijoicola</i>	Highly endangered (one record only) and other species occur on the same host (<i>Acca sellowiana</i>)	Crous et al. (2019b)
<i>C. hippeastri</i>	Highly endangered (few records), from <i>Hippeastrum</i> sp.; last detection in 2009	Damm et al. (2012b)
<i>C. parsonsiae</i>	Rare, from <i>Bletilla ochracea</i> and <i>Parsonsia capsularis</i>	Damm et al. (2012b) and Tao et al. (2013)
<i>C. phyllanthi</i>	Very rare; detected once in 1966 from <i>Phyllanthus acidus</i> and recently as an epiphyte on <i>Carapichea ipecacuanha</i>	Damm et al. (2012b) and Ferreira et al. (2020)
<i>C. torulosum</i>	Highly endangered (few records only) and other species occur on the same hosts (<i>Passiflora edulis</i> , <i>Solanum melongena</i> and <i>Kunzea ericoides</i>); last detection in 2004	Joshee et al. (2009) and Damm et al. (2012b)
Caudatum complex		
<i>C. alcornii</i>	Highly endangered (two records only), from <i>Bothriochloa bladhii</i> and <i>Imperata cylindrica</i> ; last detection in 1973	Crouch (2014)
<i>C. baltimoreense</i>	Highly endangered (one record only) and other species occur on the same host (<i>Sorghastrum nutans</i>)	Crouch (2014)
<i>C. caudatum</i>	Highly endangered (two records only) and other species occur on the same host (<i>Sorghastrum nutans</i>); last detection in 2007	Crouch (2014)
<i>C. caudisporum</i>	Highly endangered (one record only) and other species occur on the same host (<i>Bletilla ochracea</i>)	Tao et al. (2013)
<i>C. duyunense</i>	Highly endangered (one record only) and other species occur on the same host (<i>Bletilla ochracea</i>)	Tao et al. (2013)
<i>C. ochraceae</i>	Highly endangered (two records only) and other species occur on the same host (<i>Bletilla ochracea</i>)	Tao et al. (2013)
<i>C. somersetense</i>	Highly endangered (one record only) and other species occur on the same host (<i>Sorghastrum nutans</i>)	Crouch (2014)
<i>C. zoysiae</i>	Highly endangered (one record only), from <i>Zoysia tenuifolia</i> ; single detection in 1998	Crouch (2014)
Dematium complex		
<i>C. anthrisci</i>	Highly endangered (one record only), from <i>Anthriscus sylvestris</i>	Damm et al. (2009)

Table 9 (continued)

Species	Notes	References
<i>C. eryngiicola</i>	Highly endangered (one record only) and other species occur on the same host (<i>Eryngium campestre</i>)	Buyck et al. (2017)
<i>C. hemerocallidis</i>	Highly endangered (two records only) and other species occur on the same host (<i>Hemerocallis fulva</i>)	Yang et al. (2012b)
<i>C. insertae</i>	Highly endangered (one record only) and other species occur on the same host (<i>Parthenocissus inserta</i>)	Hyde et al. (2016)
<i>C. jinshuiense</i>	Highly endangered (one record only) and other species occur on the same host (<i>Pyrus pyrifolia</i>)	Fu et al. (2019)
<i>C. kakiivorum</i>	Highly endangered (two records only) and other species occur on the same host (<i>Diospyrus kaki</i>)	Lee and Jung (2018)
<i>C. menispermi</i>	Highly endangered (one record only), from <i>Menispermum dauricum</i>	Li et al. (2016c)
<i>C. parthenocissicola</i>	Highly endangered (one record only) and other species occur on the same host (<i>Parthenocissus quinquefolia</i>)	Yuan et al. (2020)
<i>C. quinquefoliae</i>	Highly endangered (one record only) and other species occur on the same host (<i>Parthenocissus quinquefolia</i>)	Li et al. (2016c)
<i>C. sambucicola</i>	Highly endangered (one record only) and other species occur on the same host (<i>Sambucus ebulus</i>)	Tibpromma et al. (2017)
Destructivum complex		
<i>C. antirrhinicola</i>	Highly endangered (one record only) and other species occur on the same host (<i>Antirrhinum majus</i>); single detection in 1999	Damm et al. (2014)
<i>C. atractylodicola</i>	Highly endangered (one record only) and other species occur on the same host (<i>Atractylodes lancea</i>)	Xu et al. (2018b)
<i>C. bryoniicola</i>	Endangered (two records only), from <i>Bryonia dioica</i> and <i>Salvia nemerosa</i>	Damm et al. (2014) and Guarnaccia et al. (2019)
<i>C. neorubicola</i>	Highly endangered (two records only) and other species occur on the same host (<i>Rubus idaeus</i>)	Liu et al. (2020c)
<i>C. shisoii</i>	Endangered (one record only), from <i>Perilla frutescens</i>	Gan et al. (2019)
<i>C. tabacum</i>	Rare, from <i>Nicotiana</i> spp. and <i>Centella asiatica</i> ; last detection in 2003	Damm et al. (2014)
<i>C. utrechtense</i>	Highly endangered (one record only) and other species occur on the same host (<i>Trifolium pratense</i>)	Damm et al. (2014)
Dracaenophilum complex		
<i>C. cariniferi</i>	Highly endangered (one record only), from <i>Dendrobium cariniferum</i>	Ma et al. (2018)
<i>C. excelsum-altitudinum</i>	Highly endangered (one record only) and other species occur on the same host (<i>Bletilla ochracea</i>)	Tao et al. (2013)
<i>C. tongrenense</i>	Endangered (one record only), from <i>Nothapodytes pittosporoides</i>	Zhou et al. (2019)
<i>C. tropicicola</i>	Endangered (three records only), from <i>Citrus</i> sp. and <i>Paphiopedilum bellatulum</i> ; species in state of delimitation	Noireung et al. (2012) and Damm et al. (2019)
Gigasporum complex		
<i>C. arxii</i>	Highly endangered (two records only), from orchids	Liu et al. (2014)
<i>C. jishouense</i>	endangered (one record only), from <i>Nothapodytes pittosporoides</i>	Zhou et al. (2019)
<i>C. serranegrense</i>	Highly endangered (one record only), from <i>Cattleya jongheana</i>	Silva et al. (2018)
Gloeosporioides complex		
<i>C. arecicola</i>	Rare, from <i>Areca catechu</i>	Cao et al. (2020)
<i>C. artocarpicola</i>	Highly endangered (one record only), from <i>Artocarpus heterophyllus</i>	Bhunjun et al. (2019)
<i>C. changpingense</i>	Highly endangered (two records only) and other species occur on the same host (<i>Fragaria</i> × <i>ananassa</i>)	Jayawardena et al. (2016b)

Table 9 (continued)

Species	Notes	References
<i>C. chiangmaiense</i>	Highly endangered (one record only) and other species occur on the same host genus (<i>Magnolia</i>)	de Silva et al. (2021b)
<i>C. clidemiae</i>	Rare, from <i>Clidemia hirta</i> and <i>Vitis</i> sp.	Weir et al. (2012)
<i>C. cobbittiense</i>	Highly endangered (one record only) and other species occur on the same host (<i>Cordyline stricta</i> × <i>australis</i>)	Crous et al. (2018c)
<i>C. conoides</i>	Highly endangered (two records only) and other species occur on the same hosts (<i>Capsicum annuum</i> var. <i>conoides</i> and <i>Pyrus pyrifolia</i>)	Diao et al. (2017) and Fu et al. (2019)
<i>C. cycadis</i>	Endangered (one record only), from <i>Cycas revoluta</i>	Crous et al. (2020)
<i>C. dracaenigenum</i>	Highly endangered (one record only) and other species occur on the same host (<i>Dracaena</i>)	Chaiwan et al. (2021)
<i>C. fructivorum</i>	No recent reports; mostly from <i>Vaccinium</i> spp.	Doyle et al. (2013)
<i>C. grossum</i>	Highly endangered (two records only) and other species occur on the same host (<i>Capsicum annuum</i>)	Diao et al. (2017) and Guarnaccia et al. (2021)
<i>C. hedericola</i>	Highly endangered (one record only) and other species occur on the same host (<i>Hedera helix</i>)	Hyde et al. (2020a)
<i>C. helleniense</i>	Highly endangered (two records only) and other species occur on the same hosts (<i>Citrus</i> spp.)	Guarnaccia et al. (2017)
<i>C. henanense</i>	Endangered (few records) and other species occur on the same hosts (<i>Camellia</i> spp. and <i>Cirsium japonicum</i>)	Liu et al. (2015a) and Li et al. (2018c)
<i>C. hystricis</i>	Highly endangered (one record only) and other species occur on the same host (<i>Citrus hystrix</i>)	Guarnaccia et al. (2017)
<i>C. jiangxiense</i>	Endangered (few records) and other species occur on the same host (<i>Camellia sinensis</i> and <i>Dendrobium</i> sp.)	Liu et al. (2015a) and Ma et al. (2018)
<i>C. nupharicola</i>	Rare, from waterlilies and <i>Persea americana</i>	Weir et al. (2012) and Sharma et al. (2017)
<i>C. perseae</i>	Rare, from <i>Persea americana</i>	Sharma et al. (2017)
<i>C. pseudotheobromicola</i>	Highly endangered (one record only) and other species occur on the same host (<i>Prunus avium</i>)	Chethana et al. (2016)
<i>C. syzygiicola</i>	Endangered (few records) and other species infected the same hosts (<i>Citrus aurantifolia</i> , <i>Elettaria cardamomum</i> and <i>Syzygium samarangense</i>)	Udayanga et al. (2013) and Chethana et al. (2016)
<i>C. temperatum</i>	Highly endangered (two records only) and other species occur on the same host (<i>Vaccinium macrocarpon</i>)	Doyle et al. (2013)
<i>C. ti</i>	Endangered (few records) and other species occur on the same host (<i>Cordyline australis</i>); last detection in 1992	Weir et al. (2012)
<i>C. wuxiense</i>	Endangered (few records) and other species occur on the same hosts (<i>Camellia sinensis</i> and <i>Pyrus pyrifolia</i>)	Wang et al. (2016) and Fu et al. (2019)
<i>C. xanthorrhoeae</i>	Endangered (few records), from <i>Xanthorrhoea</i> sp.; last detection in 1994	Weir et al. (2012)
<i>C. xishuangbannaense</i>	Highly endangered (one record only) and other species occur on the same host genus (<i>Magnolia</i>)	de Silva et al. (2021b)
<i>C. yulongense</i>	Highly endangered (one record only) and other species occur on the same host (<i>Vaccinium dunalianum</i>)	Wang et al. (2019b)
Graminicola complex		
<i>C. axonopodi</i>	Rare, from <i>Axonopus</i> spp.; last detection in 1983	Crouch et al. (2009a)
<i>C. eleusines</i>	Highly endangered (two records only), from <i>Eleusine indica</i> ; last detection in 1977	Crouch et al. (2009a)
<i>C. endophytum</i>	Highly endangered (two records only) and other species occur on the same host (<i>Bletilla ochracea</i>)	Tao et al. (2013)
<i>C. eremochloae</i>	Rare, from <i>Eremochloa ophiuroides</i> ; last detection in 2007	Crouch and Tomaso-Peterson (2012)
<i>C. hanau</i>	Highly endangered (few records), from <i>Digitaria</i> spp.; last detection in 1975	Crouch et al. (2009a)

Table 9 (continued)

Species	Notes	References
<i>C. jacksonii</i>	Highly endangered (few ancient records) and other species occur on the same host (<i>Echinochloa</i> spp.); last detection in 1985	Crouch et al. (2009a)
<i>C. miscanthi</i>	Highly endangered (one recent record only) and other species occur on the same hosts (<i>Miscanthus sinensis</i> and <i>Bletilla ochracea</i>); last detection in 2006	Crouch et al. (2009a) and Tao et al. (2013)
<i>C. nicholsonii</i>	Possibly extinct; from <i>Paspalum dilatatum</i> ; last detection in 1975	Crouch et al. (2009a)
<i>C. paspali</i>	Possibly extinct; from <i>Paspalum notatum</i> ; last detection in 1977	Crouch et al. (2009a)
Magnum complex		
<i>C. cacao</i>	Possibly extinct; single detection at an unknown (presumably ancient) date and other species occur on the same host (<i>Theobroma cacao</i>)	Damm et al. (2019)
<i>C. liaoningense</i>	Endangered (few records) and other species infect the same hosts (<i>Capsicum annuum</i> and <i>Mangifera indica</i>)	Li et al. (2019b)
<i>C. lobatum</i>	Possibly extinct; single detection at an unknown (presumably ancient) date and other species occur on the same host (<i>Piper catalpaefolium</i>)	Damm et al. (2019)
<i>C. magnum</i>	Endangered (few records) and other species infect the same hosts (<i>Carica papaya</i> , <i>Citrullus lanatus</i> and <i>Lobelia chinensis</i>)	Li et al. (2013), Tapia-Tussell et al. (2016) and Damm et al. (2019)
<i>C. merremiae</i>	Highly endangered (one record only) and other species occur on the same host (<i>Merremia umbellata</i>)	Damm et al. (2019)
<i>C. okinawense</i>	Endangered (few records) and other species occur on the same host (<i>Carica papaya</i>)	Damm et al. (2019) and Dias et al. (2020)
<i>C. panamense</i>	Highly endangered (one record only) and other species occur on the same host (<i>Merremia umbellata</i>)	Damm et al. (2019)
Orbiculare complex		
<i>C. bidentis</i>	Highly endangered (one record only), from <i>Bidens subalternans</i>	Damm et al. (2013)
<i>C. malvarum</i>	Highly endangered (few records), from <i>Malva</i> sp. and <i>Lavatera trimestris</i> ; last detection in 1997	Damm et al. (2013)
<i>C. sidae</i>	Highly endangered (one record only), from <i>Sida spinosa</i> ; single detection in 1988	Damm et al. (2013)
<i>C. spinosum</i>	Few records, from <i>Xanthium spinosum</i> only	Damm et al. (2013)
<i>C. tebeestii</i>	Rare, from <i>Malva pusilla</i> ; single detection in 1982	Damm et al. (2013)
Orchidearum complex		
<i>C. musicola</i>	Endangered (few records), from <i>Musa</i> sp., <i>Colocasia esculenta</i> and <i>Glycine max</i>	Damm et al. (2019), Vásquez-López et al. (2019) and Bouffleur et al. (2021)
Spaethianum complex		
<i>C. bletillae</i>	Highly endangered (one record only) and other species occur on the same host (<i>Bletilla ochracea</i>)	Tao et al. (2013)
<i>C. guizhouense</i>	Few records, from <i>Bletilla ochracea</i> and <i>Huperzia phlegmaria</i>	Tao et al. (2013) and Zhang et al. (2015)
<i>C. incanum</i>	Endangered (few records) and other species occur on the same hosts (<i>Capsicum</i> sp. and <i>Glycine max</i>)	Yang et al. (2014) and Diao et al. (2017)
<i>C. riograndense</i>	Endangered (one record only), from <i>Tradescantia fluminensis</i>	Macedo et al. (2016)
<i>C. verruculosum</i>	Possibly extinct, from <i>Crotalaria juncea</i> ; single detection in 1951	Damm et al. (2009)
Truncatum complex		
<i>C. acidae</i>	Highly endangered (one record only), from <i>Phyllanthus acidus</i>	Samarakoon et al. (2018)

complexes, and common species more frequently found in the gloeosporioides, spaethianum, acutatum, orchidearum and destructivum complexes (Fig. 19).

Under the current knowledge 130 *Colletotrichum* species are known only from a single country and can therefore considered as endemisms. By country, these are:

- Australia—*C. brisbanense* and *C. cairnsense* (acutatum complex), *C. alcornii* (caudatum complex), *C. tanacetii* (destructivum complex) and *C. australianum*, *C. cobbitiense* and *C. xanthorrhoeae* (gloeosporioides complex);
- Brazil—*C. paranaense* (acutatum complex), *C. brasiliense* (boninense complex), *C. serranegrense* (gigasporum complex), *C. bidentis* (orbiculare complex) and *C. riograndense* (spaethianum complex);
- Canada—*C. tebeestii* (orbiculare complex);
- Chile—*C. arboricola* and *C. roseum* (acutatum complex);
- China—*C. eriobotryae* and *C. miaoliense* (acutatum complex), *C. hongqingense* (boninense complex), *C. caudisporum*, *C. duyunense* and *C. ochraceae* (caudatum complex), *C. hemerocallidis* and *C. jinshuiense* (dematium complex), *C. atractylodicola* and *C. neorubicola* (destructivum complex), *C. excelsum-altitudinum*, *C. tongrenense* and *C. yunnanense* (dracaenophilum complex), *C. jishouense* and *C. pseudomajus* (gigasporum complex), *C. arenicola*, *C. changpingense*, *C. conoides*, *C. cycadis*, *C. hebeiense*, *C. henanense*, *C. pseudothobromicola*, *C. tainanense*, *C. wuxiense*, *C. xishuangbannaense* and *C. yulongense* (gloeosporioides complex), *C. endophytum* and *C. hainanense* (graminicola complex), *C. liaoningense* (magnum complex), *C. bletillae* and *C. guizhouense* (spaethianum complex) and *C. citrus-medicae*, *C. bambusicola*, *C. guangxiense*, *C. sydowii* and *C. pyrifoliae* (singleton species);
- Colombia—*C. annellatum* and *C. colombiense* (boninense complex);
- Costa Rica—*C. costaricense* (acutatum complex), *C. radicis* (gigasporum complex) and *C. cacao* (magnum complex);
- Dominica—*C. cuscutae* (acutatum complex);
- Germany—*C. oncidii* (boninense complex) and *C. coelogyne* (dracaenophilum complex);
- Greece—*C. helleniense* (gloeosporioides complex);
- India—*C. guajavae* (acutatum complex) and *C. vittalense* (orchidearum);
- Indonesia—*C. indonesiense* and *C. javanense* (acutatum complex) and *C. makassarensis* (gloeosporioides complex);
- Italy – *C. lauri* (acutatum complex), *C. sambucicola* and *C. sonchicola* (dematium complex), *C. orchidis* (destructivum complex), *C. grevilleae*, *C. hedericola*, *C. hystricis* and *C. psidii* (gloeosporioides complex) and *C. rusci* (singleton species);
- Japan—*C. camelliae-japonicae* (boninense complex), *C. zoysiae* (caudatum complex), *C. shisoii* (destructivum complex) and *C. echinocloae* and *C. paspali* (graminicola complex);
- Korea—*C. kakiivorum* (dematium complex);
- Netherlands—*C. cosmi* (acutatum complex), *C. anthrisci* (dematium complex) and *C. utrechtense* (destructivum complex);
- New Zealand—*C. acerbum* and *C. johnstonii* (acutatum complex), *C. beeveri*, *C. constrictum*, *C. dacrycarpi*, *C. novae-zelandiae* and *C. torulosum* (boninense complex), *C. antirrhinicola* (dematium complex) and *C. ti* (gloeosporioides complex);
- Nigeria—*C. vignae* (destructivum complex);
- Panama—*C. merremiae* and *C. panamense* (magnum complex);
- Portugal—*C. feijoicola* (boninense complex);
- Russia—*C. eryngiicola*, *C. insertae*, *C. menispermi*, *C. parthenocissicola*, *C. quinquefoliae* and *C. sedi* (dematium complex);
- Saint Lucia—*C. paxtonii* (acutatum complex);
- South Africa—*C. euphorbiae*, *C. ledebouriae* and *C. neosansevieraie* (agaves complex), *C. pleopeltidis* (destructivum complex) and *C. proteae* (gloeosporioides complex);
- Thailand—*C. doitungense* (boninense complex), *C. cariniferi* and *C. parallelophorum* (dracaenophilum complex), *C. artocarpicola*, *C. chiangmaiense*, *C. dracaenigenum* and *C. pandanicola* (gloeosporioides complex) and *C. acidae* (truncatum complex);
- Trinidad and Tobago—*C. lobatum* (magnum complex);
- UK—*C. kniphofiae* (acutatum complex);
- USA—*C. baltimorensis*, *C. caudatum* and *C. somersetense* (caudatum complex), *C. fructi* (dematium complex), *C. rhexiae* and *C. temperatum* (gloeosporioides complex), *C. navitas* (graminicola complex) and *C. sidae* (orbiculare complex);
- Vietnam—*C. walleri* (acutatum complex), *C. condaoense* (boninense complex) and *C. vietnamense* (gigasporum complex);
- Zimbabwe—*C. verruculosum* (spaethianum complex).

Conclusions, implications and future perspectives

In this work we have listed 257 species of *Colletotrichum*, clustering in 15 species complexes (some species are not assigned to any complex). Species complexes in *Colletotrichum* (as well as in other genera that have also experienced

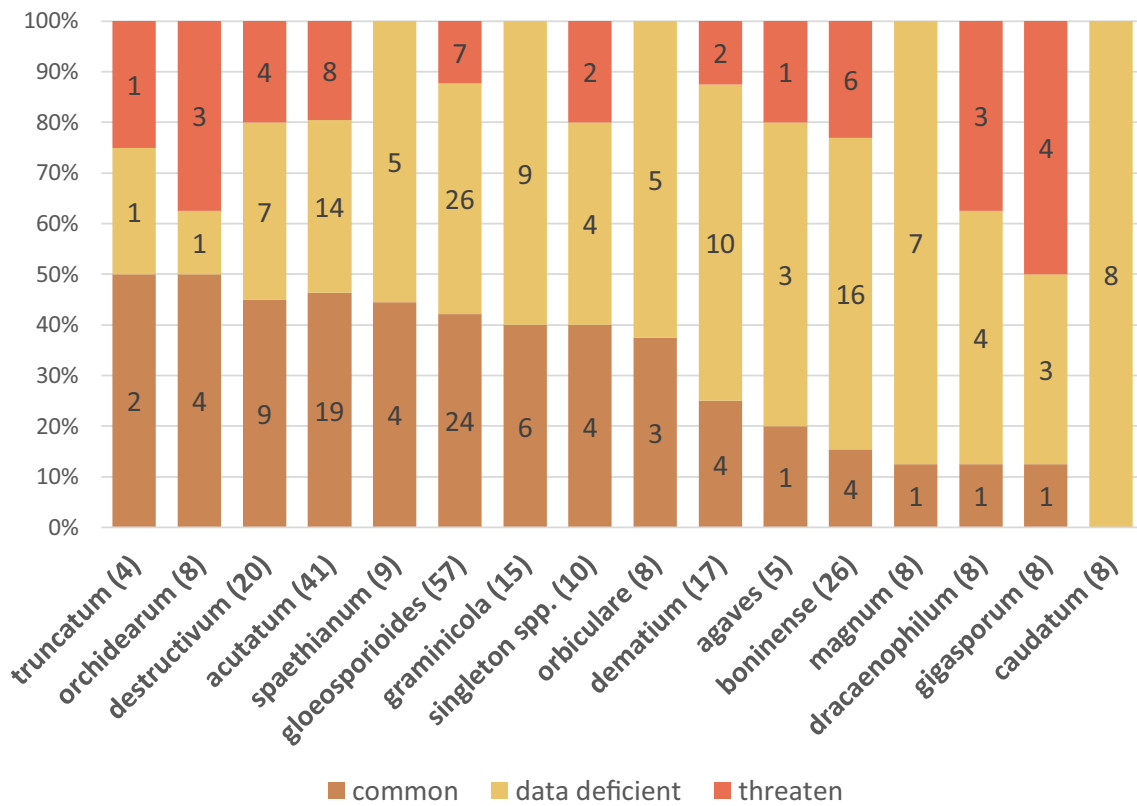

Fig. 19 Relative and absolute frequency of the number of *Colletotrichum* species considered “common”, “data deficient” and “threatened” in each species complex

a recent rapid increase in the number of species recognised) gained high practical relevance but, anachronistically, they lack formal definition. For instance, when referring to *C. abscissum*, authors frequently use expressions such as “*Colletotrichum abscissum* of the *acutatum* complex”, which is a complicated and unfriendly designation. In the future, and as the phylogeny of *Colletotrichum* progresses to a mature and stable condition, species complexes may gain formal taxonomic value and become infra-generic taxa.

In this work we have also highlighted difficulties and challenges regarding species delimitation and identification. Two species have been rejected as they turned out to be defined based on chimeric sequences that, once concatenated, suggested these to be novel taxa, but individually, were identical to those of previously described species. When describing new species it is fundamental that the sequence of each gene is compared to sequences of the type strains of existing species and not just the concatenated sequence of diverse genes. The employment of multiple loci in taxonomy is highly recommended (e.g., Lücking et al. 2020; Aime et al. 2021) but the examples provided here emphasise the relevance of analysing each locus individually. Chimeric multilocus sequences are quite perverse, as they affect the tree topology and, when applied, the time calibration. Depositing fungal cultures in

living collections (but also providing accurate information on their substrates and collection location in nature) is fundamental for current and future understanding of these fungi (as detailed by Aime et al. 2021). It is expected that fungal whole genome sequencing (WGS) will soon become easier and cheaper, and this will allow most research laboratories to start in-house WGS projects on a daily basis. Providing genome data for type strains will soon become good practice that should be implemented when describing new species. The use of WGS will support the identification and the description of new species by:

- extended MLST approaches such as phylogenomic analyses;
- quantification of genetic interchange between taxonomic groups; this will also help resolve the situation of chimeric strains or hybrids (e.g. by analysing genomic portion or loci into different datasets established by congruent tree topologies);
- time estimation of genetic isolation;
- the identification of the genetic factors involved in important biological processes such as those linked with the speciation process.

Nevertheless, strains from new species should also be characterised considering their life styles, with pathogenicity/host range/substrate usage studies being highly recommended to be included along the description of novel species.

In this work we have considered a total of 2711 occurrence reports of *Colletotrichum* strains that could be confidently traced to species under current taxonomic criteria. When revising literatures from the last 10 years we were particularly careful in scrutinising the use of multilocus analyses (when necessary) for identification by comparison to sequences from the type strains of the candidate species. In several circumstances we did not consider identification reports that were based on single gene information (when more than one gene was required to identify a given species) nor those based only on BLAST identification. BLAST searches are adequate for preliminary identification of candidate target species, but then the sequence(s) of the strain to be identified should be compared to the sequences of the type strains of the several species that are phylogenetically close to the candidate target species identified in the BLAST search. A recent analysis showed that ca. 30% of ITS sequences available in nucleotide sequence databases are associated to a wrong fungal taxon (Hofstetter et al. 2019) and this holds true in the *Colletotrichum* genus (Bouffeur et al. 2021). Here (Supplemental Data 1) we present the most recent table listing species of *Colletotrichum* and the respective GenBank references for ITS, *gapdh*, *chs-1*, *act* and *tub2* sequences. Ensuring that identification of strains is performed scrupulously is fundamental for a stable and meaningful utilisation of species in *Colletotrichum*, both from taxonomical and plant pathology perspectives.

Whereas conservation status of animal and plant species are of major concern, fungi have deserved much less attention, and still mostly focused on macrofungi and lichens. The IUCN Red List of Threatened species (www.iucnredlist.org) lists the conservation status of 343 fungal species (as compared to ca. 43,500 plant and 76,500 animal species), including 62 Ascomycota among which only seven Sordariomycetes, none of which from the Glomerellales. Microfungi, and plant pathogens in particular, are notoriously absent from such lists. The IUCN Red List system is recognised as the most authoritative for the evaluation of biological conservation and criteria have been adapted to use in fungi (Dahlberg and Mueller 2011) and Conservation Mycology has been recently recognised as a discipline within Conservation Biology (May et al. 2018), but macrofungi take most of the attention and plant pathology was clearly excluded from fungal conservation (Dahlberg et al. 2010), as fungal plant pathogens fail to meet the criteria according to which fungi can be readily integrated into conservation (Heilmann-Clausen et al. 2014). The conservation of microfungi, with emphasis on those that are not directly observable because of

their endophytic or otherwise latent nature, has been subject of attention recently (Blackwell and Vega 2018). Metagenomics analyses of fungal communities in given ecosystems can provide the means to obtain abundant occurrence data (Blackwell and Vega 2018), but current approaches, based on DNA barcode genes of large phylogenetic spectrum (Hibbett et al. 2016), do not enable the discrimination of several species of *Colletotrichum*, for which specific markers are needed. In other words, under current delimitation, species of *Colletotrichum* are not directly identifiable in nature nor can be identified based on broad (i.e. ITS-based) metagenomics approaches. Ascertaining whether a species of *Colletotrichum* is threatened thus faces additional problems to those raised by Blackwell and Vega (2018). In this work we have opted to use informal classifications of the conservation status of *Colletotrichum* species as the employment of criteria as defined by Dahlberg and Mueller (2011) is not possible for most species. Recently Aime et al. (2021) provided updated guidelines on “How to publish a new fungal species or name”, among which stand the recommendation to “include multiple collections of specimens or cultured isolates when describing a new species”, in sharp contrast with the fact that 145 of the currently recognised species of *Colletotrichum* (i.e., 56.4% of the 257 species) have been recorded no more than two times from nature. Conservation is structurally based on the concept of species, but the threshold for the classification of fungal species has varied strongly over the last decades, with the history of *Colletotrichum* taxonomy being paradigmatic of this. Conservation of *Colletotrichum* species is thus critically dependent on a stable taxonomic framework. Species denoted as “data deficient” in this work may in fact turn out to be common and even of pathological relevance, but further monitoring is needed, joining efforts between Conservation Mycology and Plant Pathology, an area in which the generalisation of WGS approaches may provide a decisive help. The present study, providing a comprehensive review of accepted species of *Colletotrichum* and their clustering into complexes, along with the compilation of occurrence data, provides a basis for subsequent studies linking taxonomy and conservation of *Colletotrichum* species and on the role of these fungi as plant pathogens of major agricultural crops worldwide.

Supplementary Information The online version contains supplementary material available at <https://doi.org/10.1007/s13225-021-00491-9>.

Funding This research was financially supported by the R&D unit LEAF (FCT/UID/AGR/04129/2020; Fundação para a Ciência e a Tecnologia, Portugal).

Availability of data and material Detailed occurrence data are supplied in supplementary material.

Declarations

Conflict of interest The authors declare no conflicts of interest/competing interests.

References

- Abirami K, Sakthivel K, Sheoran N, Baskaran V, Gautam RK, Jerard BA, Kumar A (2019) Occurrence of Anthracnose disease caused by *Colletotrichum siamense* on dragon fruit (*Hylocereus undatus*) in Andaman Islands, India. *Plant Dis* 103:768. <https://doi.org/10.1094/PDIS-09-18-1489-PDN>
- Afanador-Kafuri L, González A, Gañán L, Mejía JF, Cardona N, Alvarez E (2014) Characterization of the *Colletotrichum* species causing Anthracnose in Andean Blackberry in Colombia. *Plant Dis* 98:1503–1513. <https://doi.org/10.1094/PDIS-07-13-0752-RE>
- Ahmad T, Wang J, Zheng Y, Mugizi AE, Moosa A, Nie C, Liu Y (2021) First record of *Colletotrichum alienum* causing postharvest Anthracnose disease of mango fruit in China. *Plant Dis*. <https://doi.org/10.1094/pdis-09-20-2074-pdn> (in press)
- Ahn GR, Choi MA, Kim JI, Seo EJ, Kim JY, Kim SW (2017) A report of eighteen unrecorded fungal species in Korea. *Korean J Mycol* 45:292–303. <https://doi.org/10.4489/KJM.20170037>
- Aime MC, Miller AN, Aoki T, Bensch K, Cai L, Crous PW, Hawsworth DL, Hyde KD, Kirk PM, Lücking R, May TW, Malosso E, Redhead SA, Rossman AY, Stadler M, Thines M, Yurkov AM, Zhang N, Schoch CL (2021) How to publish a new fungal species, or name, version 3.0. *IMA Fungus* 12:11. <https://doi.org/10.1186/s43008-021-00063-1>
- Akgül DS, Awan QN, Güler PG, Önelge N (2016) First report of Anthracnose and stem end rot diseases caused by *Colletotrichum gloeosporioides* and *Neofusicoccum australe* on Avocado fruits in Turkey. *Plant Dis* 100:1792. <https://doi.org/10.1094/PDIS-03-16-0279-PDN>
- Aktaruzzaman M, Afroz T, Lee Y-G, Kim B-S (2018) Post-harvest anthracnose of papaya caused by *Colletotrichum truncatum* in Korea. *Eur J Plant Pathol* 150:259–265. <https://doi.org/10.1007/s10658-017-1265-y>
- Alam MW, Rehman A, Hameed A, Sarwar M, Tahir U, Hussain M, Hussain D, Shafeeq T (2021) First record of *Colletotrichum gloeosporioides* causing Anthracnose of banana in Pakistan. *Plant Dis*. <https://doi.org/10.1094/pdis-01-21-0215-pdn> (in press)
- Alaniz S, Hernández L, Mondino P (2015) *Colletotrichum fructicola* is the dominant and one of the most aggressive species causing bitter rot of apple in Uruguay. *Trop Plant Pathol* 40:265–274. <https://doi.org/10.1007/s40858-015-0025-9>
- Alaniz S, Cuzzo V, Martínez V, Mondino P (2019) Ascospore infection and *Colletotrichum* species causing Glomerella leaf spot of apple in Uruguay. *Plant Pathol J* 35:100–111. <https://doi.org/10.5423/PPJ.OA.07.2018.0145>
- Aldaoud R, DeAlwis S, Salib S, Cunnington JH, Doughty S (2011) First record of *Colletotrichum sansevieriae* on *Sansevieria* sp. (mother-in-law's tongue) in Australia. *Australas Plant Dis Notes* 6:60–61. <https://doi.org/10.1007/s13314-011-0020-z>
- Almaraz-Sánchez A, Ayala-Escobar V, Landero-Valenzuela N, Tlailpa-Santamaría IF, Nieto-Angel D (2019) First report of *Colletotrichum truncatum* of *Solanum lycopersicum* in Mexico. *Plant Dis* 103:1782. <https://doi.org/10.1094/PDIS-10-18-1809-PDN>
- Almeida LB, Matos KS, Assis LAG, Hanada RE, Silva GF (2017) First report of Anthracnose of *Capsicum chinense* in Brazil caused by *Colletotrichum brevisporum*. *Plant Dis* 101:1035. <https://doi.org/10.1094/PDIS-01-17-0099-PDN>
- Al-Obaidi JR, Mohd Hanafi N, Hong TH (2017) First report of anthracnose on wax apple in Malaysia caused by *Colletotrichum gloeosporioides*. *J Plant Pathol* 99:287. <https://doi.org/10.4454/jpp.v99i1.3793>
- Álvarez E, Gañán L, Rojas-Triviño A, Mejía JF, Llano GA, González A (2014) Diversity and pathogenicity of *Colletotrichum* species isolated from soursop in Colombia. *Eur J Plant Pathol* 139:325–338. <https://doi.org/10.1007/s10658-014-0388-7>
- An HJ, Na HB, Lim TH, ChangT SJ, Lee DW (2018) Sensitivity variation to demethylation inhibiting fungicides of *Colletotrichum horii*, isolated Anthracnose pathogens from persimmon tree in Sangju and Yeongdong. *Korean J Pestic Sci* 22:177–183. <https://doi.org/10.7585/kjps.2018.22.3.177>
- Anderson JM, Aitken EAB, Dann EK, Coates LM (2013) Morphological and molecular diversity of *Colletotrichum* spp. causing pepper spot and anthracnose of lychee (*Litchi chinensis*) in Australia. *Plant Pathol* 62:279–288. <https://doi.org/10.1111/j.1365-3059.2012.02632.x>
- Araújo MBM, Lima CS, Rabelo Filho FAC, Ootani MA, Bezerra AME, Cardoso JE (2018) First report of *Colletotrichum theobromicola* and *C. tropicale* causing Anthracnose on fruits of carnauba palm in Brazil. *Plant Dis* 102:244. <https://doi.org/10.1094/PDIS-06-17-0860-PDN>
- Ariyawansa HA, Hyde KD, Jayasiri SC, Buyck B, Chethana KWT, Dai DQ, Dai YC, Daranagama DA, Jayawardena RS, Lücking R, Ghobad-Nejhad M, Niskanen T, Thambugala KM, Voigt K, Zhao RL, Li G-J, Doilom M, Boonmee S, Yang ZL, Cai Q, Cui Y-Y, Bahkali AH, Chen J, Cui BK, Chen JJ, Dayarathne MC, Disanayake AJ, Ekanayaka AH, Hashimoto A, Hongsanan S, Jones EBG, Larsson E, Li WJ, Li Q-R, Liu JK, Luo ZL, Maharachchikumbura SSN, Mapook A, McKenzie EHC, Norphanphou C, Kanta S, Pang KL, Perera RH, Phookamsak R, Phukhamsakda C, Pinruan U, Randrianjohany E, Singtripop C, Tanaka K, Tian CM, Tibpromma S, Abdel-Wahab MA, Wanasinghe DN, Wijayawardene NN, Zhang J-F, Zhang H, Abdel-Aziz FA, Wedin M, Westberg M, Ammirati JF, Bulgakov TS, Lima DX, Callaghan TM, Callac P, Chang C-H, Coca LF, Dal-Forno M, Dollhofer V, Fliegerová K, Greiner K, Griffith GW, Ho H-M, Hofstetter V, Jeewon R, Kang JC, Wen T-C, Kirk PM, Kytövuori I, Lawrey JD, Xing K, Li H, Liu ZY, Liu XZ, Liimatainen K, Lumbsch HT, Matsumura M, Moncada B, Nuankaew S, Parnmen S, Santiago ALCMA, Sommai S, Song Y, Souza CAF, Souza-Motta CM, Su HY, Suetrong S, Wang Y, Wei S-F, Wen TC, Yuan HS, Zhou LW, Réblová M, Fournier J, Camporesi E, Luangsarn-ard JJ, Tسانathai K, Khonsanit A, Thanakitpipattana D, Somrithipol S, Diederich P, Millanes AM, Common RS, Stadler M, Yan JY, Li XH, Lee HW, Nguyen TTT, Lee HB, Battistin E, Marsico O, Vizzini A, Vila J, Ercole E, Eberhardt U, Simonini G, Wen H-A, Chen X-H, Miettinen O, Spirin V, Hernawati (2015) Fungal diversity notes 111–252—taxonomic and phylogenetic contributions to fungal taxa. *Fungal Divers* 75:27–274. <https://doi.org/10.1007/s13225-015-0346-5>
- Australia Group (2014) Australia Group Common Control List Handbook—Volume II: biological weapons-related common control lists. <http://www.australiagroup.net>
- Ayvar-Serna S, Díaz-Nájera JF, Mena-Bahena A, Ortiz-Montes BE, Alvarado-Gómez OG, Lima NB, Tovar-Pedraza JM (2020) First report of leaf Anthracnose caused by *Colletotrichum tropicale* on Oregano (*Origanum vulgare*) in Mexico. *Plant Dis* 104:1855. <https://doi.org/10.1094/PDIS-01-20-0169-PDN>
- Ayvar-Serna S, Díaz-Nájera JF, Vargas-Hernández M, Camacho-Tapia M, Valencia-Rojas GA, Lima NB, Tovar-Pedraza JM (2021) First report of *Colletotrichum jiangxiense* causing Avocado Anthracnose in Mexico. *Plant Dis* 105:502. <https://doi.org/10.1094/PDIS-03-20-0459-PDN>

- Bailey JA, Jegger MJ (1992) *Colletotrichum: biology, pathology and control*. BSPP/CAB International, Wallingford. ISBN: 0 85198 756 7
- Barimani M, Pethybridge SJ, Vaghefi N, Hay FS, Taylor PWJ (2013) A new Anthracnose disease of pyrethrum caused by *Colletotrichum tanacetii* sp. nov. *Plant Pathol* 62:1248–1257. <https://doi.org/10.1111/ppa.12054>
- Baroncelli R, Sreenivasaprasad S, Thon MR, Sukno SA (2014) First report of apple bitter rot caused by *Colletotrichum godetiae* in the United Kingdom. *Plant Dis* 98:1000. <https://doi.org/10.1094/PDIS-11-13-1177-PDN>
- Baroncelli R, Sarrocco S, Zapparata A, Tavarini S, Angelini LG, Vannacci G (2015) Characterization and epidemiology of *Colletotrichum acutatum* sensu lato (*C. chrysanthemi*) causing *Carthamus tinctorius* anthracnose. *Plant Pathol* 64:375–384. <https://doi.org/10.1111/ppa.12268>
- Baroncelli R, Talhinhos P, Pensec F, Sukno SA, Le Floch G, Thon M (2017) The *Colletotrichum acutatum* species complex as a model system to study evolution and host specialization in plant pathogens. *Front Microbiol* 8:2001. <https://doi.org/10.3389/fmicb.2017.02001>
- Batista D, Silva DN, Vieira A, Cabral A, Pires AS, Loureiro A, Guerra-Guimarães L, Pereira AP, Azinheira H, Talhinhos P, Silva MC, Várzea V (2017) Legitimacy and implications of reducing *Colletotrichum kahawae* to subspecies in plant pathology. *Front Plant Sci* 7:2051. <https://doi.org/10.3389/fpls.2016.02051>
- Bedlan G (2012) *Mahonia aquifolium* – a new host of *Colletotrichum japonicum* comb. nov. *J Kulturpfl* 64:478–481
- Bellé C, Ramos RF, Gabriel M, Kaspary TE, Brida AL (2019) *Colletotrichum gloeosporioides* causing leaf anthracnose on *Oxalis corniculata* in Brazil. *Australas Plant Dis Notes* 14:36. <https://doi.org/10.1007/s13314-019-0367-0>
- Ben HY, HuoJF YZR, Gao W, Wang WL, Hao YJ, Zhang XY (2020) First report of *Colletotrichum capsici* causing Anthracnose on *Alocasia macrorrhizos* in China. *Plant Dis* 104:1203. <https://doi.org/10.1094/PDIS-06-20-1228-PDN>
- Benatar GV, Wibowo A, Suryanti (2021) First report of *Colletotrichum asianum* associated with mango fruit anthracnose in Indonesia. *Crop Protect* 141:105432. <https://doi.org/10.1016/j.cropro.2020.105432>
- Bezerra JP, Ferreira PV, Barbosa LF, Ramos-Sobrinho R, Pinho DB, Reis A, Assunção IP, Lima GSA (2016) First report of Anthracnose on chayote fruits (*Sechium edule*) caused by *Colletotrichum brevisporum*. *Plant Dis* 100:217. <https://doi.org/10.1094/PDIS-07-15-0793-PDN>
- Bhadoria V, MacLachlan R, Pozniak C, Cohen-Skalie A, Li L, Halliday J, Banniza S (2019) Genetic map-guided genome assembly reveals a virulence-governing minichromosome in the lentil anthracnose pathogen *Colletotrichum lentis*. *New Phytol* 221:431–445. <https://doi.org/10.1111/nph.15369>
- Bhunjun CS, Jayawardena RS, Wei D-P, Huanraluek N, Abeywickrama PD, Jeewon R, Monkai J, Hyde K (2019) Multigene phylogenetic characterisation of *Colletotrichum artocarpicola* sp. nov. from *Artocarpus heterophyllus* in northern Thailand. *Phytotaxa* 418:273–286. <https://doi.org/10.11646/phytotaxa.418.3.3>
- Bhunjun CS, Phukhamsakda C, Jayawardena RS, Jeewon R, Promptutha I, Hyde K (2021) Investigating species boundaries in *Colletotrichum*. *Fungal Divers* 107:107–127. <https://doi.org/10.1007/s13225-021-00471-z>
- Bi Y, Guo W, Zhang GJ, Liu SC, Chen Y (2017a) First report of *Colletotrichum truncatum* causing Anthracnose of strawberry in China. *Plant Dis* 101:832. <https://doi.org/10.1094/PDIS-07-16-1036-PDN>
- Bi Y, Guo W, Zhang GJ, Liu SC, Yang BD (2017b) First report of *Colletotrichum boninense* causing Anthracnose of strawberry in China. *Plant Dis* 101:250. <https://doi.org/10.1094/PDIS-06-16-0828-PDN>
- Blackwell M, Vega FE (2018) Lives within lives: hidden fungal biodiversity and the importance of conservation. *Fungal Ecol* 35:127–134. <https://doi.org/10.1016/j.funeco.2018.05.011>
- Borges RCF, Rossato M, Santos MDM, Macedo MA, Fonseca MEN, Boiteux LS, Reis A (2021) *Colletotrichum siamense* as a causal agent of leaf anthracnose in seedlings of *Annona muricata* in nurseries from the Federal District, Brazil. *J Plant Dis Protect* 128:583–588. <https://doi.org/10.1007/s41348-020-00406-x>
- Bouffleur TR, Ciampi-Guillardi M, Tikami Í, Rogério F, Thon MR, Sukno SA, Massola Júnior NS, Baroncelli R (2021) Soybean anthracnose caused by *Colletotrichum species*: current status and future prospects. *Mol Plant Pathol* 22:393–409. <https://doi.org/10.1111/mpp.13036>
- Bragança CAD, Nogueira Junior AF, Rogério F, Massola NS Jr (2014) First report of Anthracnose caused by *Colletotrichum theobromicola* on Barbados Cherry (*Malpighia emarginata*) in Brazil. *Plant Dis* 98:1272. <https://doi.org/10.1094/PDIS-01-14-0099-PDN>
- Bragança CAD, Damm U, Baroncelli R, Massola Júnior NS, Crous PW (2016) Species of the *Colletotrichum acutatum* complex associated with anthracnose diseases of fruit in Brazil. *Fungal Biol* 120:547–561. <https://doi.org/10.1016/j.funbio.2016.01.011>
- Buchta V, Nekolová J, Jirásková N, Bolehovská R, Wipler J, Hubka V (2019) Fungal Keratitis caused by *Colletotrichum dematium*: case study and review. *Mycopathologia* 184:441–453. <https://doi.org/10.1007/s11046-019-00335-w>
- Bunker RN, Tanwar NS, Aggarwal SK (2019) Management of Sorghum Anthracnose caused by *Colletotrichum graminicola* (Ces.) Wilson. *Int J Curr Microbiol App Sci* 8:1364–1371. <https://doi.org/10.20546/ijemas.2019.810.159>
- Buyck B, Duhem B, Das K, Jayawardena RS, Niveiro N, Pereira OL, Prasher IB, Adhikari S, Albertó EO, Bulgakov TS, Castañeda-Ruiz RF, Hembrom ME, Hyde KD, Lewis DP, Michlig A, Nuytinck J, Parihar A, Popoff OF, Ramirez NA, Silva M, Verma RK, Hofstetter V (2017) Fungal biodiversity profiles 21–30. *Cryptogam Mycol* 38:101–146. <https://doi.org/10.7872/crym/v38.iss1.2017.101>
- Buyoyu P, Maino MK, Okpul T (2017) First report of *Colletotrichum gloeosporioides* species complex causing anthracnose on leaves of cutnut, *Barringtonia edulis*, in Papua New Guinea. *New Dis Rep* 35:7. <https://doi.org/10.5197/j.2044-0588.2017.035.007>
- Cabral A, Azinheira HG, Talhinhos P, Batista D, Ramos AP, Silva MC, Oliveira H, Várzea V (2020) Pathological, morphological, cytogenomic, biochemical and molecular data support the distinction between *Colletotrichum cigarro* comb. et stat. nov. and *Colletotrichum kahawae*. *Plants* 9:502. <https://doi.org/10.3390/plants9040502>
- Cacciola SA, Gilardi G, Faedda R, Schena L, Pane A, Garibaldi A, Gullino ML (2020) Characterization of *Colletotrichum ocimi* population associated with black spot of Sweet Basil (*Ocimum basilicum*) in Northern Italy. *Plants* 9:654. <https://doi.org/10.3390/plants9050654>
- Cai ZY, Liu YX, Shi YP, Mu HJ, Li GH (2016a) First report of leaf Anthracnose caused by *Colletotrichum karstii* of rubber tree in China. *Plant Dis* 100:2528. <https://doi.org/10.1094/PDIS-04-16-0577-PDN>
- Cai ZY, Yang Y, Liu YX, Zhang YM, Long JM, Li HQ (2016b) First report of *Colletotrichum chlorophyti* causing *Moringa oleifera* Anthracnose in China. *Plant Dis* 100:2164. <https://doi.org/10.1094/PDIS-03-16-0336-PDN>
- Caicedo JD, Lalangui KP, Pozo AN, Cevallos PA, Arahana VS, Méndez KS (2017) Multilocus molecular identification and phylogenetic analysis of *Colletotrichum tamarilloi* as the causal agent of Tamarillo (*Solanum betaceum*) anthracnose in the Ecuadorian

- highlands. *Eur J Plant Pathol* 148:983–996. <https://doi.org/10.1007/s10658-017-1155-3>
- Caires NP, Pinho DB, Souza JSC, Silva MA, Lisboa DO, Pereira OL, Furtado GQ (2014) First report of Anthracnose on pepper fruit caused by *Colletotrichum scovillei* in Brazil. *Plant Dis* 98:1437. <https://doi.org/10.1094/PDIS-04-14-0426-PDN>
- Çakır E, Karahan A, Kurbetli İ (2019) Involvement of *Colletotrichum coccodes* causing atypical symptoms of potato tubers in Turkey. *J Plant Dis Protect* 126:173–176. <https://doi.org/10.1007/s41348-019-00206-y>
- Camele I, Mang SM, Elshafie HS, Frisullo S (2018) First report of *Colletotrichum acutatum* causing Anthracnose in *Feijoa sellowiana* in Italy. *Plant Dis* 102:1850. <https://doi.org/10.1094/PDIS-01-18-0183-PDN>
- Cannon P (2019) *Colletotrichum fuscum*. Fungi of Great Britain and Ireland. <http://fungi.myspecies.info/taxonomy/term/8861/descriptions>. Accessed 20 May 2020
- Cannon PF, Bridge PD, Monte E (2000) Linking the past, present and future of *Colletotrichum* systematics. In: Prusky D, Freeman S, Dickman MB (eds) *Colletotrichum*: host specificity, pathology and host-pathogen interaction. APS Press, St. Paul, pp 1–20
- Cannon PF, Buddie AG, Bridge PD (2008) The typification of *Colletotrichum gloeosporioides*. *Mycotaxon* 104:189–204
- Cannon PF, Damm U, Johnston PR, Weir BS (2012) *Colletotrichum*—current status and future directions. *Stud Mycol* 73:181–213. <https://doi.org/10.3114/sim0014>
- Cao XR, Xu XM, Che HY, West JS, Luo DQ (2019a) Characteristics and distribution of *Colletotrichum* species in coffee plantations in Hainan, China. *Plant Pathol* 68:1146–1156. <https://doi.org/10.1111/ppa.13028>
- Cao XR, Xu XM, Che HY, West JS, Luo DQ (2019b) Three *Colletotrichum* species, including a new species, are associated to leaf Anthracnose of rubber tree in Hainan, China. *Plant Dis* 103:117–124. <https://doi.org/10.1094/PDIS-02-18-0374-RE>
- Cao XR, Xu XM, Che HY, West JS, Luo DQ (2020) Eight *Colletotrichum* species, including a novel species, are associated with areca palm Anthracnose in Hainan, China. *Plant Dis* 104:1369–1377. <https://doi.org/10.1094/PDIS-10-19-2077-RE>
- Cara M, Illiadi MK, Lagogianni CS, Paplomatas E, Merkuri J, Tsitsigiannis DI (2021) First report of *Colletotrichum acutatum* causing Anthracnose on olives in Albania. *Plant Dis* 105:495. <https://doi.org/10.1094/PDIS-04-20-0774-PDN>
- Carbone MJ, Moreira V, Mondino P, Alaniz S (2021) First report of Anthracnose on peach fruit caused by *Colletotrichum siamense* in Uruguay. *Plant Dis*. <https://doi.org/10.1094/PDIS-05-21-0950-PDN> (in press)
- Carraro TA, Lichtemberg PSF, Michailides TJ, Pereira WV, Figueiredo JAG, May-De Mio LL (2019) First report of *Colletotrichum fructicola*, *C. nymphaeae*, and *C. melonis* causing persimmon Anthracnose in Brazil. *Plant Dis* 103:2692. <https://doi.org/10.1094/PDIS-12-18-2241-PDN>
- Cavalcante GRS, Vieira WAS, Michereff SJ, Barguil BM, Doyle VP, Câmara MPS (2018) First report of Anthracnose caused by *Colletotrichum sichuanensis* on *Phaseolus lunatus* in Brazil. *Plant Dis* 102:680. <https://doi.org/10.1094/PDIS-07-17-0963-PDN>
- Chai AL, Zhao Q, Li BJ, Sinsiri W (2018) First report of Anthracnose caused by *Colletotrichum brevisporum* on Gac (*Momordica cochinchinensis*) in Thailand. *Plant Dis* 102:2378. <https://doi.org/10.1094/PDIS-04-18-0674-PDN>
- Chaiwan N, Tibpromma S, Jayawardena R, Mapook A, Wanasinghe DN, Mortimer PE, Lumyoung S, Hyde KD (2021) *Colletotrichum dracaenigenum*, a new species on *Dracaena fragrans*. *Phytotaxa* 491:143–157. <https://doi.org/10.11646/phytotaxa.491.2.4>
- Chang T, Hassan O, Jeon JY, Shin JS, Oh NK, Lim TH (2018a) First report of Anthracnose of persimmon (*Diospyros kaki* L. f.) caused by *Colletotrichum siamense* in Korea. *Plant Dis* 102:443. <https://doi.org/10.1094/PDIS-07-17-0958-PDN>
- Chang TH, Hassan O, Lee YS (2018b) First report of Anthracnose of Japanese plum (*Prunus salicina*) caused by *Colletotrichum nymphaeae* in Korea. *Plant Dis* 102:1461. <https://doi.org/10.1094/PDIS-01-18-0018-PDN>
- Chattaoui M, Raya MC, Bouri M, Moral J, Perez-Rodriguez M, Trapero A, Msallem M, Rhouma A (2016) Characterization of a *Colletotrichum* population causing anthracnose disease on Olive in northern Tunisia. *J Appl Microbiol* 120:1368–1381. <https://doi.org/10.1111/jam.13096>
- Chaves TP, Miranda ARG, Paz LC, Netto MSB, Lima GSA, Assunção IP (2019) First detection of *Colletotrichum siamense* causing anthracnose on *Alpinia purpurata*. *J Plant Pathol* 101:435. <https://doi.org/10.1007/s42161-018-00206-1>
- Chechi A, Stahlecker J, Zhang M, Luo CX, Schnabel G (2019) First report of *Colletotrichum fiorinae* and *C. nymphaeae* causing Anthracnose on cherry tomatoes in South Carolina. *Plant Dis* 103:1042. <https://doi.org/10.1094/PDIS-09-18-1696-PDN>
- Chen Y-H, Huang T-P (2018) First report of Anthracnose caused by *Colletotrichum capsici* on passion fruit in Taiwan. *Plant Dis* 102:2648. <https://doi.org/10.1094/PDIS-03-18-0462-PDN>
- Chen YJ, Tong HR, Wei X, Yuan LY (2016a) First report of brown blight disease on *Camellia sinensis* caused by *Colletotrichum acutatum* in China. *Plant Dis* 100:227. <https://doi.org/10.1094/PDIS-07-15-0762-PDN>
- Chen QH, Li BJ, Liu PQ, Weng QY (2016b) First report of Anthracnose caused by *Colletotrichum gloeosporioides* on *Anoectochilus roxburghii* in China. *Plant Dis* 100:531. <https://doi.org/10.1094/PDIS-08-15-0902-PDN>
- Chen X, Wang T, Guo H, Zhu PK, Xu L (2019a) First report of Anthracnose of *Camellia sasanqua* caused by *Colletotrichum aenigma* in China. *Plant Dis* 103:1423. <https://doi.org/10.1094/PDIS-11-18-1971-PDN>
- Chen CJ, Ji CY, Li Y, Zhang YR, Chen C, Zeng BS, Wang XR (2019b) First report of twig Anthracnose of *Albizia falcataria* caused by *Colletotrichum gloeosporioides* in China. *Plant Dis* 103:148. <https://doi.org/10.1094/PDIS-03-18-0507-PDN>
- Chen S-Y, Hou X-M, Yang S, Tan L-L (2019c) First report of *Colletotrichum liriopes* causing leaf spots on *Liriope spicata* in China. *Plant Dis* 103:1422. <https://doi.org/10.1094/PDIS-11-18-1969-PDN>
- Chen XY, Dai DJ, Zhao SF, Shen Y, Wang HD, Zhang CQ (2020) Genetic diversity of *Colletotrichum* spp. causing strawberry Anthracnose in Zhejiang. *China Plant Dis* 104:1351–1357. <https://doi.org/10.1094/PDIS-09-19-2026-RE>
- Chen T, Wang T, Gou Y, Wang L, Li C (2021) Identification of *Colletotrichum liriopes* as the causative agent of Anthracnose in Buckwheat (*Fagopyrum esculentum*) in China. *Plant Dis*. <https://doi.org/10.1094/PDIS-04-21-0689-PDN> (in press)
- Cheng BP, Huang YH, Song XB, Peng AT, Ling JF, Chen X (2013) First report of *Colletotrichum siamense* causing leaf drop and fruit spot of *Citrus reticulata* Blanco cv. Shiyue Ju in China. *Plant Dis* 97:1508. <https://doi.org/10.1094/PDIS-04-13-0352-PDN>
- Cheng BP, Huang YH, Peng AT, Ling JF, Song XB, Chen X (2014) First report of leaf and fruit spot of *Citrus reticulata* Blanco cv. Nian Ju caused by *Colletotrichum truncatum* in China. *Plant Dis* 98:422. <https://doi.org/10.1094/PDIS-07-13-0712-PDN>
- Cheng S, Jiang J-W, Hsiang T, Sun Z-X, Zhou Y (2019) First report of Anthracnose on *Machilus ichangensis* caused by *Colletotrichum siamense* in China. *Plant Dis* 103:2958. <https://doi.org/10.1094/PDIS-05-19-1115-PDN>
- Cheon W, Jeon Y (2016) First report of Anthracnose caused by *Colletotrichum spaethianum* on fragrant plantain lily in Korea. *Plant Dis* 100:1498. <https://doi.org/10.1094/PDIS-11-15-1341-PDN>

- Cheon W, Lee SG, Jeon Y (2016) First report on fruit spot caused by *Colletotrichum gloeosporioides* in apple (*Malus pumila* Mill.) in Korea. *Plant Dis* 100:210. <https://doi.org/10.1094/PDIS-11-14-1165-PDN>
- Chethana CS, Chowdappa P, Biju CN, Praveena R, Sujatha AM (2016) Molecular and phenotypic characterization revealed six *Colletotrichum* species responsible for anthracnose disease of small cardamom in South India. *Eur J Plant Pathol* 146:465–481. <https://doi.org/10.1007/s10658-016-0931-9>
- Chethana KWT, Jayawardene RS, Zhang W, Zhou YY, Liu M, Hyde KD, Li XH, Wang J, Zhang KC, Yan JY (2019) Molecular characterization and pathogenicity of fungal taxa associated with cherry leaf spot disease. *Mycosphere* 10:490–530. <https://doi.org/10.5943/mycosphere/10/1/8>
- Choi KJ, Kim WG, Kim HG, Choi HW, Lee YK, Lee BD, Lee SY, Hong SK (2011) Morphology, molecular phylogeny and pathogenicity of *Colletotrichum panacicola* causing Anthracnose of Korean Ginseng. *Plant Pathol J* 27:1–7. <https://doi.org/10.5423/PPJ.2011.27.1.001>
- Choi H-W, Lee YK, Hong SK (2017) First report of *Colletotrichum aenigma* causing Anthracnose on *Sedum kamtschaticum* in Korea. *Plant Dis* 101:2150. <https://doi.org/10.1094/PDIS-07-17-0938-PDN>
- Choi H-W, Hong SK, Lee YH, Yoon YN (2021) First report of *Colletotrichum sublineola* causing Anthracnose on *Sorghum bicolor* in South Korea. *Plant Dis*. <https://doi.org/10.1094/pdis-03-20-0637-pdn> (in press)
- Chou T, Xu W, Mukhtar I, Quan X, Jiang S, Huang R, Chen B, Xie B (2019) First report of leaf spot disease caused by *Colletotrichum siamense* on *Chrysalidocarpus lutescens* in China. *Plant Dis* 103:1425. <https://doi.org/10.1094/PDIS-11-18-2049-PDN>
- Chowdappa P, Chethana CS, Pant RP, Bridge PD (2014) Multilocus gene phylogeny reveals occurrence of *Colletotrichum cymbidicola* and *C. cliviae* on orchids in North East India. *J Plant Pathol* 96:327–334. <https://doi.org/10.4454/JPP.V96I2.045>
- Chung P-C, Wu H-Y, Huang Y-W, Ariyawansa HA, Hu H-P, Hung T-H, Tzeng S-S, Chung C-L (2020) Diversity and pathogenicity of *Colletotrichum* species causing strawberry anthracnose in Taiwan and description of a new species, *Colletotrichum miaoliense* sp. nov. *Sci Rep* 10:14664. <https://doi.org/10.1038/s41598-020-70878-2>
- Conforto C, Lima NB, Garcete-Gómez JM, Câmara MPS, Michereff SJ (2017) First report of *Colletotrichum siamense* and *C. fructicola* causing cladode brown spot in *Nopalea cochenillifera* in Brazil. *J Plant Pathol* 99:812. <https://doi.org/10.4454/jpp.v99i3.3974>
- Cong Y, Liu Z, Liu L, Yang L, Gao J (2018) First report of leaf spot on radix asteris (*Aster tataricus*) caused by *Colletotrichum destructivum* in China. *Plant Dis* 102:1029. <https://doi.org/10.1094/PDIS-11-16-1566-PDN>
- Cong YL, Hou J, Liu LP, Liu ZY, Pan Y, Zhang XM, Hu TJ, Liu F, Yu Y (2020) First report of Anthracnose disease caused by *Colletotrichum truncatum* on the velvetleaf (*Abutilon theophrasti*) in China. *Plant Dis* 104:565. <https://doi.org/10.1094/PDIS-08-19-1657-PDN>
- Costa JFO, Kamei SH, Silva JRA, Miranda ARGS, Netto MB, Silva SJC, Correia KC, Lima GSA, Assunção IP (2019) Species diversity of *Colletotrichum* infecting *Annona* spp. in Brazil. *Eur J Plant Pathol* 153:1119–1130. <https://doi.org/10.1007/s10658-018-01630-w>
- Cristóbal-Martínez AL, Yáñez-Morales MJ, Solano-Vidal R, Segura-León O, Hernández-Anguiano AM (2017) Diversity of *Colletotrichum* species in coffee (*Coffea arabica*) plantations in Mexico. *Eur J Plant Pathol* 147:605–614. <https://doi.org/10.1007/s10658-016-1029-0>
- Crouch JA (2014) *Colletotrichum caudatum* s.l. is a species complex. *IMA Fungus* 5:17–30. <https://doi.org/10.5598/ima fungus.2014.05.01.03>
- Crouch JA, Beirn LA (2009) Anthracnose of cereals and grasses. *Fungal Divers* 39:19–44
- Crouch JA, Tomaso-Peterson M (2012) Anthracnose disease of centipede-grass turf caused by *Colletotrichum eremochloae*, a new fungal species closely related to *Colletotrichum sublineola*. *Mycologia* 104:1085–1096. <https://doi.org/10.3852/11-317>
- Crouch JA, Clarke BB, White JF Jr, Hillman BI (2009a) Systematic analysis of the falcate-spored graminicolous *Colletotrichum* and a description of six new species from warm-season grasses. *Mycologia* 101:717–732. <https://doi.org/10.3852/08-230>
- Crouch JA, Beirn LA, Cortese LM, Bonos SA, Clarke BB (2009b) Anthracnose disease of switchgrass caused by the novel fungal species *Colletotrichum navitas*. *Mycol Res* 113:1411–1421. <https://doi.org/10.1016/j.mycres.2009.09.010>
- Crous PW, Wingfield MJ, Guarro J, Cheewangkoon R, van der Bank M, Swart WJ, Stchigel AM, Cano-Lira JF, Roux J, Madrid H, Damm U, Wood AR, Shuttleworth LA, Hodges CS, Munster M, Yáñez-Morales MJ, Zúñiga-Estrada L, Cruywagen EM, De Hoog GS, Silvera C, Najafzadeh J, Davison EM, Davison PJN, Barrett MD, Barrett RL, Manamgoda DS, Minnis AM, Kleczewski NM, Flory SL, Castlebury LA, Clay K, Hyde KD, Maússe-Sitoe SND, Chen S, Lechat C, Hairaud M, Lesage-Meessen L, Pawłowska J, Wilk M, Śliwińska-Wyrzychowska A, Mętrak M, Wrzosek M, Pavlic-Zupanc D, Maleme HM, Slippers B, Mac Cormack WP, Archuby DI, Grünwald NJ, Tellería MT, Dueñas M, Martín MP, Marinowitz S, de Beer ZW, Perez CA, Gené J, Marín-Felix Y, Groenewald JZ (2013) Fungal Planet description sheets: 154–213. *Persoonia* 31:188–296. <https://doi.org/10.3767/003158513X675925>
- Crous PW, Wingfield MJ, Guarro J, Hernández-Restrepo M, Sutton DA, Acharya K, Barber PA, Boekhout T, Dimitrov RA, Dueñas M, Dutta AK, Gené J, Gouliamova DE, Groenewald M, Lombard L, Morozova OV, Sarkar J, Smith MT, Stchigel AM, Wiederhold NP, Alexandrova AV, Antelmi I, Armengol J, Barnes I, Cano-Lira JF, Castañeda-Ruiz RF, Contu M, Courteuisse PR, Silveira AL, Decock CA, Goes A, Edathodu J, Ercole E, Firmino AC, Fourie A, Fournier J, Furtado EL, Geering ADW, Gershenzon J, Giraldo A, Gramaje D, Hammerbacher A, He X-L, Haryadi D, Khemmak W, Kovalenko AE, Krawczynski R, Laich F, Lechat C, Lopes UP, Madrid H, Malysheva EF, Marín-Felix Y, Martín MP, Mostert L, Nigro F, Pereira OL, Picillo B, Pinho DB, Popov ES, Rodas-Peláez CA, Rooney-Latham S, Sandoval-Denis M, Shivas RG, Silva V, Stoilova-Disheva MM, Tellería MT, Ullah C, Unsicker SB, van der Merwe NA, Vizzini A, Wagner H-G, Wong PTW, Wood AR, Groenewald JZ (2015) Fungal Planet description sheets: 320–370. *Persoonia* 34:167–266. <https://doi.org/10.3767/003158515X688433>
- Crous PW, Wingfield MJ, Richardson DM, Leroux JJ, Strasberg D, Edwards J, Roets F, Hubka V, Taylor PWJ, Heykoop M, Martín MP, Moreno G, Sutton DA, Wiederhold NP, Barnes CW, Carlavilla JR, Gené J, Giraldo A, Guarnaccia V, Guarro J, Hernández-Restrepo M, Kolařík M, Manjón JL, Pascoe IG, Popov ES, Sandoval-Denis M, Woudenberg JHC, Acharya K, Alexandrova AV, Alvarado P, Barbosa RN, Baseia IG, Blanchette RA, Boekhout T, Burgess TI, Cano-Lira JF, Čmoková A, Dimitrov RA, Dyakov MY, Dueñas M, Dutta AK, Esteve-Raventós F, Fedosova AG, Fournier J, Gamboa P, Gouliamova DE, Grebenc T, Groenewald M, Hanse B, Hardy GESJ, Held BW, Jurjević Ž, Kaewgrajang T, Latha KPD, Lombard L, Luangsa-ard JJ, Lysková P, Mallátová N, Manimohan P, Miller NA, Mirabol-fathy M, Morozova OV, Obodai M, Oliveira NT, Ordóñez ME, Otto EC, Paloi S, Peterson SW, Phosri C, Roux J, Salazar WA, Sánchez A, Sarria GA, Shin H-D, Silva BDB, Silva GA, Smith

- MT, Souza-Motta CM, Stchigel AM, Stoilova-Disheva MM, Sulzbacher MA, Telleria MT, Toapanta C, Traba JM, Valenzuela-Lopez N, Watling R, Groenewald JZ (2016) Fungal Planet description sheets: 400–468. *Persoonia* 36:316–458. <https://doi.org/10.3767/003158516X692185>
- Crous PW, Luangsa-ard JJ, Wingfield MJ, Carnegie AJ, Hernández-Restrepo M, Lombard L, Roux J, Barreto RW, Baseia IG, Cano-Lira JF, Martín MP, Morozova OV, Stchigel AM, Summerell BA, Brandrud TE, Dima B, García D, Giraldo A, Guarro J, Gusmão LFP, Khamsuntorn P, Noordeloos ME, Nuankaew S, Pinruan U, Rodríguez-Andrade E, Souza-Motta CM, Thangavel R, van Iperen AL, Abreu VP, Accioly T, Alves JL, Andrade JP, Bahram M, Baral H-O, Barbier E, Barnes CW, Bendiksen E, Bernard E, Bezerra JDP, Bezerra JL, Bizio E, Blair JE, Bulynkova TM, Cabral TS, Caiafa MV, Cantillo T, Colmán AA, Conceição LB, Cruz S, Cunha AOB, Darveaux BA, da Silva AL, da Silva GA, da Silva GM, da Silva RMF, de Oliveira RJV, Oliveira RL, De Souza JT, Dueñas M, Evans HC, Epifani F, Felipe MTC, Fernández-López J, Ferreira BW, Figueiredo CN, Filippova NV, Flores JA, Gené J, Ghorbani G, Gibertoni TB, Glushakova AM, Healy R, Huhndorf SM, Iturrieta-González I, Javan-Nikkhah M, Juciano RF, Jurjević Ž, Kachalkin AV, Keochanpheng K, Krisai-Greilhuber I, Li Y-C, Lima AA, Machado AR, Madrid H, Magalhães OMC, Marbach PAS, Melanda GCS, Miller AN, Mongkolsamrit S, Nascimento RP, Oliveira TGL, Ordoñez ME, Orzes R, Palma MA, Pearce CJ, Pereira OL, Perrone G, Peterson SW, Pham THG, Piontelli E, Pordel A, Quijada L, Raja HA, Rosas de Paz E, Ryvarden L, Saitta A, Salcedo SS, Sandoval-Denis M, Santos TAB, Seifert KA, Silva BDB, Smith ME, Soares AM, Sommai S, Sousa JO, Suetrong S, Susca A, Tedersoo L, Telleria MT, Thanakitpipattana D, Valenzuela-Lopez N, Visagie CM, Zapata M, Groenewald JZ (2018a) Fungal Planet description sheets: 785–867. *Persoonia* 41:238–417. <https://doi.org/10.3767/persoonia.2018.41.12>
- Crous PW, Schumacher RK, Wingfield MJ, Akulov A, Denman S, Roux J, Braun U, Burgess TI, Carnegie AJ, Váczy KZ, Guatimosim E, Schwartzburd PB, Barreto RW, Hernández-Restrepo M, Lombard L, Groenewald JZ (2018b) New and interesting fungi. 1. *Fungal Syst Evol* 1:169–215. <https://doi.org/10.3114/fuse.2018.01.08>
- Crous PW, Wingfield MJ, Burgess TI, Hardy GESJ, Gené J, Guarro J, Baseia IG, García D, Gusmão LFP, Souza-Motta CM, Thangavel R, Adamčík S, Barili A, Barnes CW, Bezerra JDP, Bordallo JJ, Cano-Lira JF, de Oliveira RJV, Ercole E, Hubka V, Iturrieta-González I, Kubátová A, Martín MP, Moreau P-A, Morte A, Ordoñez ME, Rodríguez A, Stchigel AM, Vizzini A, Abdollahzadeh J, Abreu VP, Adamčíková K, Albuquerque GMR, Alexandrova AV, Álvarez Duarte E, Armstrong-Cho C, Banniza S, Barbosa RN, Bellanger J-M, Bezerra JL, Cabral TS, Caboň M, Caicedo E, Cantillo T, Carnegie AJ, Carmo LT, Castañeda-Ruiz RF, Clement CR, Čmoková A, Conceição LB, Cruz RHSF, Damm U, da Silva BDB, da Silva GA, da Silva RMF, Santiago ALCMA, de Oliveira LF, de Souza CAF, Dénier F, Dima B, Dong G, Edwards J, Félix CR, Fournier J, Gibertoni TB, Hosaka K, Iturriaga T, Jadan M, Jany J-L, Jurjević Ž, Kolařík M, Kušan I, Landell MF, Leite Cordeiro TR, Lima DX, Loizides M, Luo S, Machado AR, Madrid H, Magalhães OMC, Marinho P, Matočec N, Mešić A, Miller AN, Morozova OV, Neves RP, Nonaka K, Nováková A, Oberlies NH, Oliveira-Filho JRC, Oliveira TGL, Papp V, Pereira OL, Perrone G, Peterson SW, Pham THG, Raja HA, Raudabaugh DB, Řehulka J, Rodríguez-Andrade E, Saba M, Schauflieroá A, Shivas RG, Simonini G, Siqueira JPZ, Sousa JO, Stajis V, Svetasheva T, Tan YP, Tkalčec Z, Ullah S, Valente P, Valenzuela-Lopez N, Abrinbana M, Viana Marques DA, Wong PTW, Xavier de Lima V, Groenewald JZ (2018c) Fungal Planet description sheets: 716–784. *Persoonia* 40:239–392. <https://doi.org/10.3767/persoonia.2018.40.10>
- Crous PW, Wingfield MJ, Lombard L, Roets F, Swart WJ, Alvarado P, Carnegie AJ, Moreno G, Luangsa-ard J, Thangavel R, Alexandrova AV, Baseia IG, Bellanger J-M, Bessette AE, Bessette AR, De la Peña-Lastra S, García D, Gené J, Pham THG, Heykoop M, Malysheva E, Malysheva V, Martín MP, Morozova OV, Noisripoom W, Overton BE, Rea AE, Sewall BJ, Smith ME, Smyth CW, Tasanathai K, Visagie CM, Adamčík S, Alves A, Andrade JP, Aninat MJ, Araujo RVB, Bordallo JJ, Bonfleur T, Baroncelli R, Barreto RW, Bolin J, Cabero J, Caboň M, Cafã G, Caffot MLH, Cai L, Carlavilla JR, Chávez R, de Castro RRL, Delgat L, Deschuyteneer D, Dios MM, Domínguez LS, Evans HC, Eyssartier G, Ferreira BW, Figueiredo CN, Liu F, Fournier J, Galli-Terasawa LV, Gil-Durán C, Glienke C, Gonçalves MFM, Gryta H, Guarro J, Himaman W, Hywel-Jones N, Iturrieta-González I, Ivanushkina NE, Jargeat P, Khalid AN, Khan J, Kiran M, Kiss L, Kochkina GA, Kolařík M, Kubátová A, Lodge DJ, Loizides M, Luque D, Manjón JL, Marbach PAS, Massola NS Jr, Mata M, Miller AN, Mongkolsamrit S, Moreau P-A, Morte A, Mujic A, Navarro-Ródenas A, Németh MZ, Nóbrega TF, Nováková A, Olariaga I, Ozerskaya SM, Palma MA, Petters-Vandresen DAL, Piontelli E, Popov ES, Rodríguez A, Requejo Ó, Rodrigues ACM, Rong IH, Roux J, Seifert KA, Silva BDB, Sklenář F, Smith JA, Sousa JB, Souza HG, De Souza JT, Švec K, Tanchaud P, Tanney JB, Terasawa F, Thanakitpipattana D, Torres-García D, Vaca I, Vaghefi N, van Iperen AL, Vasilenko OV, Verbeken A, Yilmaz N, Zamora JC, Zapata M, Jurjević Ž, Groenewald JZ (2019a) Fungal Planet description sheets: 951–1041. *Persoonia* 43:223–425. <https://doi.org/10.3767/persoonia.2019.43.06>
- Crous PW, Carnegie AJ, Wingfield MJ, Sharma R, Mughini G, Noordeloos ME, Santini A, Shouche YS, Bezerra JDP, Dima B, Guarnaccia V, Imrefi I, Jurjević Ž, Knapp DG, Kovács GM, Magistà D, Perrone G, Rämä T, Rebriev YA, Shivas RG, Singh SM, Souza-Motta CM, Thangavel R, Adhasure NN, Alexandrova AV, Alfenas AC, Alfenas RF, Alvarado P, Alves AL, Andrade DA, Andrade JP, Barbosa RN, Barili A, Barnes CW, Baseia IG, Bellanger J-M, Berlanas C, Bessette AE, Bessette AR, Biketova AY, Bomfim FS, Brandrud TE, Bransgrove K, Brito ACQ, Cano-Lira JF, Cantillo T, Cavalcanti AD, Cheewangkoon R, Chikowski RS, Conforto C, Cordeiro TRL, Craine JD, Cruz R, Damm U, de Oliveira RJV, de Souza JT, de Souza HG, Dearnaley JDW, Dimitrov RA, Dovana F, Erhard A, Esteve-Raventós F, Félix CR, Ferisín G, Fernandes RA, Ferreira RJ, Ferro LO, Figueiredo CN, Frank JL, Freire KTLs, García D, Gené J, Geşiorska A, Gibertoni TB, Gondra RAG, Gouliamova DE, Gramaje D, Guard F, Gusmão LFP, Haitook S, Hirooka Y, Houbraken J, Hubka V, Inamdar A, Iturriaga T, Iturrieta-González I, Jadan M, Jiang N, Justo A, Kachalkin AV, Kapitonov VI, Karadelev M, Karakehian J, Kasuya T, Kautmanová I, Kruse J, Kušan I, Kuznetsova TA, Landell MF, Larsson K-H, Lee HB, Lima DX, Lira CRS, Machado AR, Madrid H, Magalhães OMC, Majerova H, Malysheva EF, Mapperson RR, Marbach PAS, Martín MP, Martín-Sanz A, Matočec N, McTaggart AR, Mello JF, Melo RFR, Mešić A, Michereff SJ, Miller AN, Minoshima A, Molinero-Ruiz L, Morozova OV, Mosoh D, Nabe M, Naik R, Nara K, Nascimento SS, Neves RP, Olariaga I, Oliveira RL, Oliveira TGL, Ono T, Ordoñez ME, Ottoni AdeM, Paiva LM, Pancorbo F, Pant B, Pawłowska J, Peterson SW, Raudabaugh DB, Rodríguez-Andrade E, Rubio E, Rusevska K, Santiago ALCMA, Santos ACS, Santos C, Sazanovna NA, Shah S, Sharma J, Silva BDB, Siquier JL, Sonawane MS, Stchigel AM, Svetasheva T, Tamakeaw N, Telleria MT, Tiago PV, Tian CM, Tkalčec Z, Tomashevskaya MA, Truong HH, Vecherskii MV, Visagie CM, Vizzini A, Yilmaz N, Zmitrovich IV, Zvyagina EA, Boekhout T, Kehlet T, Læssøe T, Groenewald JZ (2019b) Fungal Planet description sheets:

- 868–950. *Persoonia* 42:291–473. <https://doi.org/10.3767/persoonia.2019.42.11>
- Crous PW, Cowan DA, Maggs-Kölling G, Yilmaz N, Larsson E, Angelini C, Brandrud TE, Dearnaley JDW, Dima B, Dovana F, Fechner N, García D, Gené J, Halling RE, Houbraken J, Leonard P, Luangsa-ard JJ, Noisripoom W, Rea-Ireland AE, Ševčíková H, Smyth CW, Vizzini A, Adam JD, Adams GC, Alexandrova AV, Alizadeh A, Álvarez Duarte E, Andjic V, Antonín V, Arenas F, Assabgui R, Ballarà J, Banwell A, Berraf-Tebbal A, Bhatt VK, Bonito G, Botha W, Burgess TI, Caboň M, Calvert J, Carvalhais LC, Courtecuisse R, Cullington P, Davoodian N, Decock CA, Dimitrov R, Di Piazza S, Drenth A, Dumez S, Eichmeier A, Etayo J, Fernández I, Fiard J-P, Fournier J, Fuentes-Aponte S, Ghanbary MAT, Ghorbani G, Giraldo A, Glushakova AM, Gouliamova DE, Guarro J, Halleen F, Hampe F, Hernández-Restrepo M, Iturrieta-González I, Jeppson M, Kachalkin AV, Karimi O, Khalid AN, Khonsanit A, Kim JI, Kim K, Kiran M, Krisai-Greilhuber I, Kučera V, Kušan I, Langenhoven SD, Lebel T, Lebeuf R, Liimatainen K, Linde C, Lindner DL, Lombard L, Mahamedi AE, Matočec N, Maxwell A, May TW, McTaggart AR, Meijer M, Mešić A, Mileto AJ, Miller AN, Molia A, Mongkolsamrit S, Muñoz Cortés C, Muñoz-Mohedano J, Morte A, Morozova OV, Mostert L, Mostowfzadeh-Ghalamfarsa R, Nagy LG, Navarro-Ródenas A, Örstadius L, Overton BE, Papp V, Para R, Peintner U, Pham THG, Pordel A, Pošta A, Rodríguez A, Romberg M, Sandoval-Denis M, Seifert KA, Semwal KC, Sewall BJ, Shivas RG, Slovák M, Smith K, Spetik M, Spies CFJ, Syme K, Tasanathai K, Thorn RG, Tkáčec Z, Tomashevskaya MA, Torres-García D, Ullah Z, Visagie CM, Voitek A, Winton LM, Groenewald JZ (2020) Fungal Planet description sheets: 1112–1181. *Persoonia* 45:251–409. <https://doi.org/10.3767/persoonia.2020.45.10>
- Crous PW, Hernández-Restrepo M, Schumacher RK, Cowan DA, Maggs-Kölling G, Marais E, Wingfield MJ, Yilmaz N, Adan OCG, Akulov A, Álvarez Duarte E, Berraf-Tebbal A, Bulgakov TS, Carnegie AJ, de Beer ZW, Decock C, Dijksterhuis J, Duong TA, Eichmeier A, Hien LT, Houbraken JAMP, Khanh TN, Liem NV, Lombard L, Lutzoni FM, Miadlikowska JM, Nel WJ, Pascoe IG, Roets F, Roux J, Samson RA, Shen M, Spetik M, Thangavel R, Thanh HM, Thao LD, van Nieuwenhuijzen EJ, Zhang LQ, Zhang Y, Zhao LL, Groenewald JZ (2021) New and interesting fungi. 4. *Fungal Syst Evol* 7:255–343. <https://doi.org/10.3114/fuse.2021.07.13>
- Cuevas-Fernández FB, Robledo-Briones AM, Baroncelli R, Trkulja V, Thon MR, Buhinicek I, Sukno SA (2019) First report of *Colletotrichum graminicola* causing maize Anthracnose in Bosnia and Herzegovina. *Plant Dis* 103:3281. <https://doi.org/10.1094/PDIS-06-19-1224-PDN>
- Da Lio D, Baroncelli R, Weill A, Le Floch G, Nodet P (2017) First report of pear bitter rot caused by *Colletotrichum fioriniae* in France. *Plant Dis* 101:1319. <https://doi.org/10.1094/PDIS-01-17-0129-PDN>
- Dahlberg A, Mueller GM (2011) Applying IUCN red-listing criteria for assessing and reporting on the conservation status of fungal species. *Fungal Ecol* 4:147–162. <https://doi.org/10.1016/j.funeco.2010.11.001>
- Dahlberg A, Genney DR, Heilmann-Clausen J (2010) Developing a comprehensive strategy for fungal conservation in Europe: current status and future needs. *Fungal Ecol* 3:50–64. <https://doi.org/10.1016/j.funeco.2009.10.004>
- Damm U, Woudenberg JHC, Cannon PF, Crous PW (2009) *Colletotrichum* species with curved conidia from herbaceous hosts. *Fungal Divers* 39:45–87
- Damm U, Cannon PF, Woudenberg JHC, Crous PW (2012a) The *Colletotrichum acutatum* species complex. *Stud Mycol* 73:37–113. <https://doi.org/10.3114/sim0010>
- Damm U, Cannon PF, Woudenberg JHC, Johnston PR, Weir BS, Tan YP, Shivas RG, Crous PW (2012b) The *Colletotrichum boninense* species complex. *Stud Mycol* 73:1–36. <https://doi.org/10.3114/sim0002>
- Damm U, Cannon PF, Liu F, Barreto RW, Guatimosim E, Crous PW (2013) The *Colletotrichum orbiculare* species complex: important pathogens of field crops and weeds. *Fungal Divers* 61:29–59. <https://doi.org/10.1007/s13225-013-0255-4>
- Damm U, O'Connell RJ, Groenewald JZ, Crous PW (2014) The *Colletotrichum destructivum* species complex—hemibiotrophic pathogens of forage and field crops. *Stud Mycol* 79:49–84. <https://doi.org/10.1016/j.simyco.2014.09.003>
- Damm U, Sato T, Alizadeh A, Groenewald JZ, Crous PW (2019) The *Colletotrichum dracaenophilum*, *C. magnum* and *C. orchidearum* species complexes. *Stud Mycol* 92:1–46. <https://doi.org/10.1016/j.simyco.2018.04.001>
- Damm U, Sun Y-C, Huang C-J (2020) *Colletotrichum eriobotryae* sp. nov. and *C. nymphaeae*, the anthracnose pathogens of loquat fruit in central Taiwan, and their sensitivity to azoxystrobin. *Mycol Prog* 19:367–380. <https://doi.org/10.1007/s11557-020-01565-9>
- Davydenko K, Vasaitis R, Stenlid J, Menkis A (2013) Fungi in foliage and shoots of *Fraxinus excelsior* in eastern Ukraine: a first report on *Hymenoscyphus pseudoalbidus*. *For Pathol* 43:462–467. <https://doi.org/10.1111/efp.12055>
- De Silva DD, Ades PK, Crous PW, Taylor PDJ (2017a) *Colletotrichum* species associated with chili anthracnose in Australia. *Plant Pathol* 66:254–267. <https://doi.org/10.1111/ppa.12572>
- De Silva DD, Crous PW, Ades PK, Hyde KD, Taylor PWJ (2017b) Life styles of *Colletotrichum* species and implications for plant biosecurity. *Fungal Biol Rev* 31:155–168. <https://doi.org/10.1016/j.fbr.2017.05.001>
- De Silva DD, Groenewald JZ, Crous PW, Ades PK, Nasruddin A, Mongkolporn O, Taylor PWT (2019) Identification, prevalence and pathogenicity of *Colletotrichum* species causing anthracnose of *Capsicum annuum* in Asia. *IMA Fungus* 10:8. <https://doi.org/10.1186/s43008-019-0001-y>
- De Silva NI, Maharachchikumbura SSN, Thambugala KM, Bhat DJ, Karunaratna SC, Tennakoon DS, Phookamsak R, Jayawardena RS, Lumyong S, Hyde KD (2021a) Morpho-molecular taxonomic studies reveal a high number of endophytic fungi from *Magnolia candolli* and *M. garrettii* in China and Thailand. *Mycosphere* 11:163–237. <https://doi.org/10.5943/mycosphere/12/1/13>
- Dean R, van Kan JAL, Pretorius ZA, Hammond-Kosack KE, Di Pietro A, Spanu PD, Rudd JJ, Dickman M, Kahmann R, Ellis J, Foster GD (2012) The top 10 fungal pathogens in molecular plant pathology. *Mol Plant Pathol* 13:414–430. <https://doi.org/10.1111/j.1364-3703.2011.00783.x>
- Deng JC, Guan YM, Wu LJ, Zhang YY (2017) First report of Anthracnose caused by *Colletotrichum gloeosporioides* on *Actinidia arguta* in China. *Plant Dis* 101:1032. <https://doi.org/10.1094/PDIS-01-16-0103-PDN>
- Diao YZ, Fan JR, Wang ZW, Liu XL (2013) First report of *Colletotrichum boninense* causing Anthracnose on pepper in China. *Plant Dis* 97:138. <https://doi.org/10.1094/PDIS-04-12-0403-PDN>
- Diao YZ, Zhang C, Lin D, Liu XL (2014) First report of *Colletotrichum truncatum* causing Anthracnose of tomato in China. *Plant Dis* 98:687. <https://doi.org/10.1094/PDIS-05-13-0491-PDN>
- Diao Y-Z, Zhang C, Liu F, Wang W-Z, Liu L, Cai L, Liu X-L (2017) *Colletotrichum* species causing anthracnose disease of chili in China. *Persoonia* 38:20–37. <https://doi.org/10.3767/003158517X692788>

- Dias LRC, Brito RAS, Melo TA, Serra IMRS (2020) First report of papaya fruit Anthracnose caused by *Colletotrichum okinawense* in Brazil. *Plant Dis* 104:573. <https://doi.org/10.1094/PDIS-06-19-1151-PDN>
- Ding H-X, Cheng H-H, Li J-Y, Liu Z-Y, Peng L-J (2020) First report of *Colletotrichum boninense* causing Anthracnose on Goldthread (*Coptis chinensis*) in China. *Plant Dis* 104:1538. <https://doi.org/10.1094/PDIS-11-19-2363-PDN>
- Ding H, Dong WP, Mo WD, Peng L, Liu Z-Y (2021) First report of *Colletotrichum boninense* causing Anthracnose on *Rosa chinensis* in China. *Plant Dis*. <https://doi.org/10.1094/PDIS-01-21-0102-PDN> (in press)
- Douanla-Meli C, Unger J-G (2017) Phylogenetic study of the *Colletotrichum* species on imported citrus fruits uncovers a low diversity and a new species in the *Colletotrichum gigasporum* complex. *Fungal Biol* 121:858–868. <https://doi.org/10.1016/j.funbio.2017.06.003>
- Douanla-Meli C, Unger JG, Langer E (2018) Multi-approach analysis of the diversity in *Colletotrichum cliviae sensu lato*. *Antonie Van Leeuwenhoek* 111(3):423–435. <https://doi.org/10.1007/s10482-017-0965-9>
- Doyle VP, Oudemans PV, Rehner SA, Litt A (2013) Habitat and host indicate lineage identity in *Colletotrichum gloeosporioides* s.l. from wild and agricultural landscapes in North America. *PLoS ONE* 8:e62394. <https://doi.org/10.1371/journal.pone.0062394>
- Du Y-X, Shi N-N, Chen W-L, Ruan H-C, Yang X-J, Gan L, Dai Y-L, Chen F-R (2017) Identification of *Colletotrichum brevisporum* causing anthracnose on passion fruit. *Can J Plant Pathol* 39:527–532. <https://doi.org/10.1080/07060661.2017.1367725>
- Duan C-H, Pan H-R, Wang C-C (2018a) First report of *Colletotrichum brevisporum* causing Anthracnose on papaya in Taiwan. *Plant Dis* 102:2375. <https://doi.org/10.1094/PDIS-03-18-0377-PDN>
- Duan L, Fan HY, Luo ZW, Hu FC, Yu NT, Chen Z, Guo LJ, He F, Deng HD (2018b) First report of leaf spot disease caused by *Colletotrichum gloeosporioides* on *Pouteria caimito* in China. *Plant Dis* 102:1448. <https://doi.org/10.1094/PDIS-11-17-1789-PDN>
- Duan CX, Guo C, Yang ZH, Sun SL, Zhu ZD, Wang XM (2019) First report of Anthracnose leaf blight of maize caused by *Colletotrichum graminicola* in China. *Plant Dis* 103:1770. <https://doi.org/10.1094/PDIS-12-18-2140-PDN>
- Dwarka DJ, Sharma G, Rajasab AH (2016) *Colletotrichum siamense* causes Anthracnose on the fruits of *Pongamia pinnata* in India. *Mycosphere* 7:492–498. <https://doi.org/10.5943/mycosphere/7/4/8>
- Eaton MJ, Edwards S, Inocencio HA, Machado FJ, Nuckles EM, Farman M, Gauthier NA, Vaillancourt LJ (2021) Diversity and cross-infection potential of *Colletotrichum* causing fruit rots in mixed-fruit Orchards in Kentucky. *Plant Dis* 105:1115–1128. <https://doi.org/10.1094/pdis-06-20-1273-re>
- Ellison CA, Sawadogo A, Braman S, Nacro S (2015) First report of *Colletotrichum truncatum* causing stem cankers on *Jatropha curcas* in Burkina Faso. *Plant Dis* 99:14–20. <https://doi.org/10.1094/PDIS-02-14-0181-RE>
- Fantinel VS, Muniz MFB, Blume E, Araújo MM, Poletto T, Silva TT, Dutra AF, Maciel CG, Harakava R (2017) First report of *Colletotrichum siamense* causing Anthracnose on *Acca sellowiana* fruits in Brazil. *Plant Dis* 101:1035. <https://doi.org/10.1094/PDIS-01-17-0096-PDN>
- Farr DT, Aime MC, Rossman AY, Palm ME (2006) Species of *Colletotrichum* on Agavaceae. *Mycol Res* 110:1395–1408. <https://doi.org/10.1016/j.mycres.2006.09.001>
- Feng FS, Zhou GY, Li H (2019) First report of *Colletotrichum siamense* causing Anthracnose on *Rosa chinensis* in China. *Plant Dis* 103:1422. <https://doi.org/10.1094/PDIS-11-18-1966-PDN>
- Fernández-Herrera E, Rentería-Martínez ME, Ramírez-Bustos II, Moreno-Salazar SF, Ochoa-Meza A, Guillén-Sánchez D (2020) *Colletotrichum karstii*: causal agent of anthracnose of *Dendrobium nobile* in Mexico. *Can J Plant Pathol* 42:514–519. <https://doi.org/10.1080/07060661.2020.1731711>
- Ferreira MC, Cantrell CL, Wedge DE, Gonçalves VN, Jacob MR, Khan S, Rosa CA, Rosa LH (2017) Diversity of the endophytic fungi associated with the ancient and narrowly endemic neotropical plant *Vellozia gigantea* from the endangered Brazilian rupestrian grasslands. *Biochem Syst Biol* 71:163–169. <https://doi.org/10.1016/j.bse.2017.02.006>
- Ferreira MC, Assis JCS, Rosa LH (2020) Diversity of endophytic fungi associated with *Carapichea ipecacuanha* from a native fragment of the Atlantic Rain Forest. *S Afr J Bot* 134:225–229. <https://doi.org/10.1016/j.sajb.2019.12.031>
- Freitas RL, Maciel-Zambolim E, Zambolim L, Lelis DT, Caixeta ET, Lopes UP, Pereira OL (2013) *Colletotrichum boninense* causing Anthracnose on coffee trees in Brazil. *Plant Dis* 97:1255. <https://doi.org/10.1094/PDIS-03-13-0229-PDN>
- Fu BZ, Yang M, Li GY, Wu JR, Zhang JZ, Han CZ (2013) First report of leaf spot disease caused by *Colletotrichum gloeosporioides* on Chinese bean tree in China. *Plant Dis* 97:138. <https://doi.org/10.1094/PDIS-03-12-0261-PDN>
- Fu Y, Patel JS, Zhang S (2015) First report of Anthracnose in common thyme (*Thymus vulgaris*) caused by *Colletotrichum destructivum* in Florida. *Plant Dis* 99:1184. <https://doi.org/10.1094/PDIS-01-15-0032-PDN>
- Fu M, Crous PW, Bai Q, Zhang PF, Xiang J, Guo YS, Zhao FF, Yang MM, Hong N, Xu WX, Wang GP (2019) *Colletotrichum* species associated with anthracnose of *Pyrus* spp. in China. *Persoonia* 42:1–35. <https://doi.org/10.3767/persoonia.2019.42.01>
- Fuentes-Aragón D, Silva-Rojas HV, Guarnaccia V, Mora-Aguilera JA, Aranda-Ocampo S, Bautista-Martínez N, Téliz-Ortiz D (2020) *Colletotrichum* species causing anthracnose on avocado fruit in Mexico: Current status. *Plant Pathol* 69:1513–1528. <https://doi.org/10.1111/ppa.13234>
- Fuentes-Aragón D, Rebollar-Alviter A, Osnaya-González M, Enciso-Maldonado GA, González-Reyes H, Silva-Rojas HV (2021) Multilocus phylogenetic analyses suggest the presence of *Colletotrichum chrysophilum* causing banana anthracnose in Mexico. *J Plant Dis Protect* 128:589–595. <https://doi.org/10.1007/s41348-020-00396-w>
- Gaffuri F, Longa CMO, Turchetti T, Danti R, Maresi G (2017) ‘Pink rot’: infection of *Castanea sativa* fruits by *Colletotrichum acutatum*. *For Pathol* 47:e12307. <https://doi.org/10.1111/efp.12307>
- Gan P, Tsushima A, Hiroyama R, Narusaka M, Takano Y, Narusaka Y, Kawaradani M, Damm U, Shirasu K (2019) *Colletotrichum shioi* sp. nov., an Anthracnose pathogen of *Perilla frutescens* in Japan: molecular phylogenetic, morphological and genomic evidence. *Sci Rep* 9:13349. <https://doi.org/10.1038/s41598-019-50076-5>
- García L, Manzano AM (2017) First report of anthracnose on chirimoya caused by *Colletotrichum tropicale* in Cuba. *J Plant Pathol* 99:806. <https://doi.org/10.4454/jpp.v99i3.3932>
- García-Estrada RS, Cruz-Lachica I, Osuna-García LA, Márquez-Zequera I (2020) First report of papaya (*Carica papaya*) Anthracnose caused by *Colletotrichum plurivorum* in Mexico. *Plant Dis* 104:589. <https://doi.org/10.1094/PDIS-05-19-0914-PDN>
- García-Lopez MT, Gordon A, Raya MC, Muñoz Díez C, Moral J (2021) First report of *Colletotrichum karstii* causing fruit Anthracnose of *Carissa grandiflora* in Spain. *Plant Dis* 105:492. <https://doi.org/10.1094/PDIS-07-20-1581-PDN>
- Garibaldi A, Gilardi G, Puglisi I, Cacciola SO, Gullino ML (2016a) First report of leaf spot caused by *Colletotrichum kahawae* on cultivated rocket (*Eruca sativa*) in Italy. *Plant Dis* 100:1240. <https://doi.org/10.1094/PDIS-11-15-1243-PDN>
- Garibaldi A, Gilardi G, Franco-Ortega S, Gullino ML (2016b) First report of leaf spot caused by *Colletotrichum kahawae* on

- American sweetgum (*Liquidambar styraciflua*) in Italy. *J Plant Pathol* 98:370. <https://doi.org/10.4454/JPP.V98I2.036>
- Garibaldi A, Gilardi G, Franco-Ortega S, Gullino ML (2016c) First report of leaf spot caused by *Colletotrichum fioriniae* on Mexican bush sage (*Salvia leucantha*) in Italy. *Plant Dis* 100:654. <https://doi.org/10.1094/PDIS-09-15-1001-PDN>
- Garibaldi A, Bertetti D, Matic S, Luongo I, Guarnaccia V, Gullino ML (2020) First report of leaf blight caused by *Colletotrichum fioriniae* on *Mahonia aquifolium* in Italy. *Plant Dis* 104:983. <https://doi.org/10.1094/PDIS-10-19-2104-PDN>
- Giraldo A, Crous PW (2019) Inside Plectosphaerellaceae. *Stud Mycol* 92:227–286. <https://doi.org/10.1016/j.simyco.2018.10.005>
- González E, Sutton TB, Correll JC (2006) Clarification of the etiology of Glomerella leaf spot and bitter rot of apple caused by *colletotrichum* spp. Based on morphology and genetic, molecular, and pathogenicity tests. *Phytopathology* 96(9):982–92. <https://doi.org/10.1094/PHYTO-96-0982>
- Grabke A, Williamson M, Henderson GW, Schnabel G (2014) First report of Anthracnose on peach fruit caused by *Colletotrichum truncatum* in South Carolina. *Plant Dis* 98:1114. <https://doi.org/10.1094/PDIS-12-13-1215-PDN>
- Grammen A, Wenneker M, Van Campenhout J, Pham KTK, Van Hemelrijck W, Bylemans D, Geeraerd A, Keulemans W (2019) Identification and pathogenicity assessment of *Colletotrichum* isolates causing bitter rot of apple fruit in Belgium. *Eur J Plant Pathol* 153:47–63. <https://doi.org/10.1007/s10658-018-1539-z>
- Guan YM, Wu LJ, Wei YJ, Zhang YY (2016) First report of *Colletotrichum dematium* causing Anthracnose on *Lycopus lucidus* in Northeastern China. *Plant Dis* 100:2535. <https://doi.org/10.1094/PDIS-12-15-1480-PDN>
- Guan YM, Liu ZB, Li MJ, Wang QX, Zhang YY (2018) First report of *Colletotrichum spaethianum* causing Anthracnose in *Atractylodes japonica* in China. *Plant Dis* 102:239. <https://doi.org/10.1094/PDIS-03-17-0443-PDN>
- Guan YM, Zhang LL, Ma YY, Zhang Y, Zhang YY (2021) First report of Anthracnose of American Ginseng caused by *Colletotrichum sojae* in Northeast China. *Plant Dis*. <https://doi.org/10.1094/PDIS-11-20-2440-PDN> (in press)
- Guarnaccia V, Groenewald JZ, Polizzi G, Crous PW (2017) High species diversity in *Colletotrichum* associated with citrus diseases in Europe. *Persoonia* 39:32–50. <https://doi.org/10.3767/persoonia.2017.39.02>
- Guarnaccia V, Gilardi G, Martino I, Garibaldi A, Gullino ML (2019) Species diversity in *Colletotrichum* causing Anthracnose of aromatic and ornamental Lamiaceae in Italy. *Agronomy* 9:613. <https://doi.org/10.3390/agronomy9100613>
- Guarnaccia V, Martino I, Gilardi G, Garibaldi A, Gullino ML (2021) *Colletotrichum* spp. causing anthracnose on ornamental plants in northern Italy. *J Plant Pathol* 103:127–137. <https://doi.org/10.1007/s42161-020-00684-2>
- Guo M, Pan YM, Dai YL, Gao ZM (2013) First report of leaf spot caused by *Colletotrichum spaethianum* on *Peucedanum praeruptorum* in China. *Plant Dis* 97:1380. <https://doi.org/10.1094/PDIS-03-13-0246-PDN>
- Guo M, Pan YM, Dai YL, Gao ZM (2014a) First report of brown blight disease caused by *Colletotrichum gloeosporioides* on *Camellia sinensis* in Anhui Province, China. *Plant Dis* 98:284. <https://doi.org/10.1094/PDIS-08-13-0896-PDN>
- Guo LW, Wu YX, Ho HH, Su YY, Mao ZC, He PF, He YQ (2014b) First report of dragon fruit (*Hylocereus undatus*) Anthracnose caused by *Colletotrichum truncatum* in China. *J Phytopathol* 162:272–275. <https://doi.org/10.1111/jph.12183>
- Hacquard S, Kracher B, Hiruma K, Münch PC, Garrido-Oter R, Thon MR, Weimann A, Damm U, Dallery J-F, Hainaut M, Henrissat B, Lespinet O, Sacristán S, van Themaat EVL, Kemen E, McHardy AC, Schulze-Lefert P, O'Connell RJ (2016) Survival trade-offs in plant roots during colonization by closely related beneficial and pathogenic fungi. *Nat Commun* 7:11362. <https://doi.org/10.1038/ncomms11362>
- Han YC, Zeng XG, Xiang FY, Ren L, Chen FY, Gu YC (2016) Distribution and characteristics of *Colletotrichum* spp. associated with Anthracnose of strawberry in Hubei. *China Plant Dis* 100:996–1006. <https://doi.org/10.1094/PDIS-09-15-1016-RE>
- Han YZ, Fan ZW, Wu CF, Wang JH, Zhao JJ (2019) First report of leaf Anthracnose caused by *Colletotrichum cliviicola* on hybrid *Pennisetum* in China. *Plant Dis* 103:2472. <https://doi.org/10.1094/PDIS-02-19-0386-PDN>
- Han S, Ma J, Li Y, Li S, Liu Y, Qiao T, Lin T, Yang C, Luo T, Xiang L, Zhu T (2021) Brown leaf spot of *Cycas debaoensis* caused by *Colletotrichum siamense* in Sichuan, China. *Plant Dis*. <https://doi.org/10.1094/pdis-10-20-2149-pdn> (in press)
- Hassan O, Lee DW, Chang T (2019a) First report of Anthracnose of persimmon caused by *Colletotrichum nymphaeae* in Korea. *Plant Dis* 103:1772. <https://doi.org/10.1094/PDIS-11-18-2114-PDN>
- Hassan O, Lee DM, Kim CH, Chang T (2019b) First report of peduncle dieback of rose caused by *Colletotrichum gloeosporioides* in Korea. *Plant Dis* 103:2682. <https://doi.org/10.1094/PDIS-03-19-0637-PDN>
- He Y, Shu C, Chen J, Zhou E (2014) First report of Anthracnose of *Alocasia macrorrhiza* caused by *Colletotrichum karstii* in Guangdong, China. *Plant Dis* 98:696. <https://doi.org/10.1094/PDIS-10-13-1046-PDN>
- He Y, Chen Q, Shu C, Yang M, Zhou E (2016) *Colletotrichum truncatum*, a new cause of anthracnose on Chinese flowering cabbage (*Brassica parachinensis*) in China. *Trop Plant Pathol* 41:183–192. <https://doi.org/10.1007/s40858-016-0086-4>
- He L, Li X, Gao Y, Li B, Mu W, Liu F (2019) Characterization and fungicide sensitivity of *Colletotrichum* spp. from different hosts in Shandong, China. *Plant Dis* 103:34–43. <https://doi.org/10.1094/PDIS-04-18-0597-RE>
- Heilmann-Clausen J, Barron ES, Boddy L, Dahlberg A, Griffith GW, Nordén J, Ovaskainen O, Perini C, Senn-Irlt B, Halme P (2014) A fungal perspective on conservation biology. *Conserv Biol* 29:61–68. <https://doi.org/10.1111/cobi.12388>
- Hernández-Lauzardo AN, Campos-Martínez A, Velázquez-del Valle MG, Flores-Moctezuma HE, Suárez-Rodríguez R, Ramírez-Trujillo JA (2015) First report of *Colletotrichum godetiae* causing Anthracnose on avocado in Mexico. *Plant Dis* 99:555. <https://doi.org/10.1094/PDIS-10-14-1019-PDN>
- Hibbett D, Abarenkov K, Kõljalg U, Öpik M, Chai B, Cole J, Wang Q, Crous P, Robert V, Helgason T, Herr JR, Kirk P, Lueschow S, O'Donnell K, Nilsson RH, Oono R, Schoch C, Smyth C, Walker DM, Porras-Alfaro A, Taylor JW, Geiser DM (2016) Sequence-based classification and identification of fungi. *Mycologia* 108:1049–1068. <https://doi.org/10.3852/16-130>
- Hofer KM, Braithwaite M, Braithwaite LJ, Sorensen S, Siebert B, Pather V, Goudie L, Williamson L, Alexander BJR, Toome-Heller M (2021) First report of *Colletotrichum fructicola*, *C. perseae*, and *C. siamense* causing anthracnose disease of avocado (*Persea americana*) in New Zealand. *Plant Dis* 105:1564. <https://doi.org/10.1094/pdis-06-20-1313-pdn>
- Hofstetter V, Buyck B, Eyssartier G, Schneé S, Gindro K (2019) The unbearable lightness of sequenced-based identification. *Fungal Divers* 96:243–284. <https://doi.org/10.1007/s13225-019-00428-3>
- Hou LW, Liu F, Duan WJ, Cai L (2016) *Colletotrichum aracearum* and *C. camelliae-japonicae*, two holomorphic new species from China and Japan. *Mycosphere* 7:1111–1123. <https://doi.org/10.5943/mycosphere/si/2c/4>
- Huang F, Chen GQ, Hou X, Fu YS, Cai L, Hyde KD, Li HY (2013) *Colletotrichum* species associated with cultivated citrus in China. *Fungal Divers* 61:61–74. <https://doi.org/10.1007/s13225-013-0232-y>

- Huang L, Li Q-C, Zhang Y, Li D-W, Ye J-R (2016) *Colletotrichum gloeosporioides* sensu stricto is a pathogen of leaf Anthracnose on evergreen spindle tree (*Euonymus japonicus*). Plant Dis 100:672–678. <https://doi.org/10.1094/PDIS-07-15-0740-RE>
- Huang L, Kim K-T, Yang J-Y, Song H, Choi G, Jeon J, Cheong K, Ko J, Xu H, Lee Y-H (2019) A high-quality draft genome sequence of *Colletotrichum gloeosporioides* sensu stricto SMCG1#C, a causal agent of Anthracnose on *Cunninghamia lanceolata* in China. Mol Plant-Microbe Interact 32:139–141. <https://doi.org/10.1094/MPMI-05-18-0144-A>
- Huang R, Sun W, Li W, Zhou C, Huang S, Tang L, Li Q, Guo T, Mo J, Ning P (2021a) First report of *Colletotrichum siamense* causing leaf spot on *Alocasia macrorrhiza* in China. Plant Dis. <https://doi.org/10.1094/pdis-11-20-2361-pdn> (in press)
- Huang Y, Zhang YQ, Hu H, Feng N (2021b) First report of Anthracnose on *Hymenocallis littoralis* caused by *Colletotrichum siamense* in China. Plant Dis. <https://doi.org/10.1094/PDIS-02-21-0405-PDN> (in press)
- Hung N, Hsiao C-H, Yang C-S, Lin H-C, Yeh L-K, Fan Y-C, Sun P-L (2020) *Colletotrichum keratitis*: a rare yet important fungal infection of human eyes. Mycoses 63:407–415. <https://doi.org/10.1111/myc.13058>
- Hunupolagama DM, Chandrasekharan NV, Wijesundera WSS, Kathiriarachchi HS, Fernando THPS, Wijesundera RLC (2017) Unveiling members of *Colletotrichum acutatum* species complex causing Colletotrichum leaf disease of *Hevea brasiliensis* in Sri Lanka. Curr Microbiol 74:747–756. <https://doi.org/10.1007/s00284-017-1238-6>
- Huo J, Wang Y, Hao Y, Yao Y, Wang Y, Zhang K, Tan X, Li Z, Wang W (2021) Genome sequence resource for *Colletotrichum scovillei*, the cause of Anthracnose disease of chili. Mol Plant-Microbe Interact 34:122–126. <https://doi.org/10.1094/MPMI-03-20-0055-A>
- Hyde KD, Hongsanan S, Jeewon R, Bhat DJ, McKenzie EHC, Jones EBG, Phookamsak R, Ariyawansa HA, Boonmee S, Zhao Q, Abdel-Aziz FA, Abdel-Wahab MA, Banmai S, Chomnunti P, Cui B-K, Daranagama DA, Das K, Dayarathne MC, Silva NI, Dissanayake AJ, Doilom M, Ekanayaka AH, Gibertoni TB, Góes-Neto A, Huang S-K, Jayasiri SC, Jayawardena RS, Konta S, Lee HB, Li W-J, Lin C-G, Liu J-K, Lu Y-Z, Luo Z-L, Manawasinghe IS, Manimohan P, Mapook A, Niskanen T, Norphanphoun C, Papizadeh M, Perera RH, Phukhamsakda C, Richter C, Santiago ALCMA, Drechsler-Santos ER, Senanayake IC, Tanaka K, Tennakoon TMD, Thambugala KM, Tian Q, Tibpromma S, Thongbai B, Vizzini A, Wanasinghe DN, Wijayawardene NN, Wu H-X, Yang J, Zeng X-Y, Zhang H, Zhang J-F, Bulgakov TS, Camporesi E, Bahkali AH, Amoozegar MA, Araujo-Neta LS, Ammirati JF, Baghela A, Bhatt RP, Bojantchev D, Buyck B, Silva GA, Lima CLF, Oliveira RJV, Souza CAF, Dai Y-C, Dima B, Duong TT, Ercole E, Mafalda-Freire F, Ghosh A, Hashimoto A, Kamolhan S, Kang J-C, Karunarathna SC, Kirk PM, Kytövuori I, Lantieri A, Liimatainen K, Liu Z-Y, Liu X-Z, Lücking R, Medardi G, Mortimer PE, Nguyen TTT, Promputtha I, Raj KNA, Reck MA, Lumyong S, Shahzadeh-Fazeli SA, Stadler M, Soudi MR, Su H-Y, Takahashi T, Tangthirasunon N, Uniyal P, Wang Y, Wen T-C, Xu J-C, Zhang Z-K, Zhao Y-C, Zhou J-L, Zhu L (2016) Fungal diversity notes 367–490: taxonomic and phylogenetic contributions to fungal taxa. Fungal Divers 80:1–270. <https://doi.org/10.1007/s13225-016-0373-x>
- Hyde KD, Norphanphoun C, Abreu VP, Bazzicalupo A, Chethana KWT, Clericuzio M, Dayarathne MC, Dissanayake AJ, Ekanayaka AH, He M-Q, Hongsanan S, Huang S-K, Jayasiri SC, Jayawardena RS, Karunarathna A, Konta S, Kušan I, Lee H, Li J, Lin C-G, Liu N-G, Lu Y-Z, Luo Z-L, Manawasinghe IS, Mapook A, Perera RH, Phookamsak R, Phukhamsakda C, Siedlecki I, Soares AM, Tennakoon DS, Tian Q, Tibpromma S, Wanasinghe DN, Xiao Y-P, Yang J, Zeng X-Y, Abdel-Aziz FA, Li W-J, Senanayake IC, Shang Q-J, Daranagama DA, Silva NI, Thambugala KM, Abdel-Wahab MA, Bahkali AH, Berbee ML, Boonmee S, Bhat DJ, Bulgakov TS, Buyck B, Camporesi E, Castañeda-Ruiz RF, Chomnunti P, Doilom M, Dovana F, Gibertoni TB, Jadan M, Jeewon R, Jones EBG, Kang J-C, Karunarathna SC, Lim YW, Liu J-K, Liu Z-Y, Plautz HL Jr, Lumyong S, Maharachchikumbura SSN, Matočec N, McKenzie EHC, Mešić A, Miller D, Pawłowska J, Pereira OL, Promputtha I, Romero AI, Ryvarden L, Su H-Y, Suetrong S, Tkalčec Z, Vizzini A, Wen T-C, Wisitrasameewong K, Wrzosek M, Xu J-C, Zhao Q, Zhao R-L, Mortimer PE (2017) Fungal diversity notes 603–708: taxonomic and phylogenetic notes on genera and species. Fungal Divers 87:1–235. <https://doi.org/10.1007/s13225-017-0391-3>
- Hyde KD, Norphanphoun C, Chen J, Dissanayake AJ, Doilom M, Hongsanan S, Jayawardena RS, Jeewon R, Perera RH, Thongbai B, Wanasinghe DN, Wisitrasameewong K, Tibpromma S, Stadler M (2018) Thailand's amazing diversity: up to 96% of fungi in northern Thailand may be novel. Fungal Divers 93:215–239. <https://doi.org/10.1007/s13225-018-0415-7>
- Hyde KD, Dong Y, Phookamsak R, Jeewon R, Bhat DJ, Jones EBG, Liu N-G, Abeywickrama PD, Mapook A, Wei D, Perera RH, Manawasinghe IS, Pem D, Bundhun D, Karunarathna A, Ekanayaka AH, Bao D-F, Li J, Samarakoon MC, Chaiwan N, Lin C-G, Phuththacharoen K, Zhang S-N, Senanayake IC, Goonasekara ID, Thambugala KM, Phukhamsakda C, Tennakoon DS, Jiang H-B, Yang J, Zeng M, Huanraluek N, Liu J-K, Wijesinghe SN, Tian Q, Tibpromma S, Brahmanage RS, Boonmee S, Huang S-K, Thiyagaraja V, Lu Y-Z, Jayawardena RS, Dong W, Yang E-F, Singh SK, Singh SM, Rana S, Lad SS, Anand G, Devadatha B, Niranjan M, Sarma VV, Liimatainen K, Aguirre-Hudson B, Niskanen T, Overall A, Alvarenga RLM, Gibertoni TB, Pfliegler WP, Horváth E, Imre A, Alves AL, Santos ACS, Tiago PV, Bulgakov TS, Wanasinghe DN, Bahkali AH, Doilom M, Elgorban AM, Maharachchikumbura SSN, Rajeshkumar KC, Haelewaters D, Mortimer PE, Zhao Q, Lumyong S, Xu J, Sheng J (2020a) Fungal diversity notes 1151–1276: taxonomic and phylogenetic contributions on genera and species of fungal taxa. Fungal Divers 100:5–277. <https://doi.org/10.1007/s13225-020-00439-5>
- Hyde KD, Norphanphoun C, Maharachchikumbura SSN, Bhat DJ, Jones EBG, Bundhun D, Chen YJ, Bao DF, Boonmee S, Calabon MS, Chaiwan N, Chethana KWT, Dai DQ, Dayarathne MC, Devadatha B, Dissanayake AJ, Dissanayake LS, Doilom M, Dong W, Fan XL, Goonasekara ID, Hongsanan S, Huang SK, Jayawardena RS, Jeewon R, Karunarathna A, Konta S, Kumar V, Lin CG, Liu JK, Liu NG, Luangsa-ard J, Lumyong S, Luo ZL, Marasinghe DS, McKenzie EHC, Niego AGT, Niranjan M, Perera RH, Phukhamsakda C, Rathnayaka AR, Samarakoon MC, Samarakoon SMBC, Sarma VV, Senanayake IC, Shang QJ, Stadler M, Tibpromma S, Wanasinghe DN, Wei DP, Wijayawardene NN, Xiao YP, Yang J, Zeng XY, Zhang SN, Xiang MM (2020b) Refined families of Sordariomycetes. Mycosphere 11:305–1059. <https://doi.org/10.5943/mycosphere/11/1/7>
- Hyde KD, Jeewon R, Chen Y-J, Bhunjun CS, Calabon MS, Jiang H-B, Lin C-G, Norphanphoun C, Sysouphanthong P, Pem D, Tibpromma S, Zhang Q, Doilom M, Jayawardena RS, Liu J-K, Maharachchikumbura SSN, Phukhamsakda C, Phookamsak R, Al-Sadi AM, Thongklang N, Wang Y, Gafforov Y, Gareth Jones EB, Lumyong S (2020c) The numbers of fungi: is the descriptive curve flattening? Fungal Divers 103:219–271. <https://doi.org/10.1007/s13225-020-00458-2>
- Iliadi MK, Tjamos EC, Antoniou PP, Tsitsigiannis DI (2018) First report of *Colletotrichum acutatum* causing Anthracnose on Olives in Greece. Plant Dis 102:820. <https://doi.org/10.1094/PDIS-09-17-1451-PDN>

- Intan Sakinah MA, Suzianti IV, Latiffah Z (2013) First report of *Colletotrichum gloeosporioides* causing Anthracnose of banana (*Musa* spp.) in Malaysia. *Plant Dis* 97:991. <https://doi.org/10.1094/PDIS-10-12-0985-PDN>
- Ismail AM, Cirvilleri G, Yaseen T, Epifani F, Perrone G, Polizzi G (2015) Characterisation of *Colletotrichum* species causing anthracnose disease of mango in Italy. *J Plant Pathol* 97:167–171. <https://doi.org/10.4454/JPP.V97I1.011>
- Ismail SI, Rahim NA, Zulperi D (2021a) First report of *Colletotrichum siamense* causing blossom blight on Thai Basil (*Ocimum basilicum*) in Malaysia. *Plant Dis* 105:1209. <https://doi.org/10.1094/pdis-06-20-1371-pdn>
- Ismail SI, Zaiwawi NLM, Abdullah S, Jamian S, Saad N (2021b) First report of *Colletotrichum siamense* causing Anthracnose on White Frangipani (*Plumeria alba* L.) in Malaysia. *Plant Dis*. <https://doi.org/10.1094/PDIS-12-20-2614-PDN>
- Jayawardena RS, Hyde KD, Damm U, Cai L, Liu M, Li XH, Zhang W, Zhao WS, Yan JY (2016a) Notes on currently accepted species of *Colletotrichum*. *Mycosphere* 7:1192–1260. <https://doi.org/10.5943/mycosphere/si/2c/9>
- Jayawardena RS, Huang JK, Jin BC, Yan JY, Li XH, Hyde KD, Bahkali AH, Yin SL, Zhang GZ (2016b) An account of *Colletotrichum* species associated with strawberry anthracnose in China based on morphology and molecular data. *Mycosphere* 7:1143–1163. <https://doi.org/10.5943/mycosphere/si/2c/6>
- Jayawardena RS, Camporesi E, Elgorban AM, Bahkali AH, Yan J, Hyde KD (2017) A new species of *Colletotrichum* from *Sonchus* sp. in Italy. *Phytotaxa* 314:55–63. <https://doi.org/10.11646/phyto-taxa.314.1.3>
- Jayawardena RS, Hyde KD, Chen YJ, Papp V, Palla B, Papp D, Bhunjun CS, Hurdeal VG, Senwana C, Manawasinghe IS, Harischandra DL, Gautam AK, Avasthi S, Chuankid B, Goonasekara ID, Hongsanan S, Zeng XY, Liyanage KK, Liu NG, Karunarathna A, Hapuararchchi KK, Luangharn T, Raspé O, Brahamage R, Doilom M, Lee HB, Mei L, Jeewon R, Huanraluek N, Chaiwan N, Stadler M, Wang Y (2020) One stop shop IV: taxonomic update with molecular phylogeny for important phytopathogenic genera: 76–100 (2020). *Fungal Divers* 103:87–218. <https://doi.org/10.1007/s13225-020-00460-8>
- Jayawardena RS, Bhunjun CS, Hyde KD, Gentekaki E, Itthayakorn P (2021) *Colletotrichum*: lifestyles, biology, morpho-species, species complexes and accepted species. *Mycosphere* 12:519–669. <https://doi.org/10.5943/mycosphere/12/1/7>
- Jeon CW, Kwak Y-S (2016) First report of Anthracnose disease caused by *Colletotrichum gloeosporioides* in Stonecrop. *J Agric Life Sci* 50:251–255. <https://doi.org/10.14397/jals.2016.50.5.251>
- Jeon JY, Hassan O, Chang T, Lee DW, Shin JS, Oh NK (2017) Anthracnose of persimmon (*Diospyros kaki*) caused by *Colletotrichum horii* in Sangju, Korea. *Plant Dis* 101:1035. <https://doi.org/10.1094/PDIS-01-17-0085-PDN>
- Ji J, Wang T, Xu X, Wang XY, Wu QQ, Li WY, Kan YC, Yao LG (2019) First report of *Colletotrichum siamense* causing leaf spot on redbud in China. *Plant Dis* 103:585. <https://doi.org/10.1094/PDIS-08-18-1331-PDN>
- Jiang SQ, Li H (2018) First report of leaf Anthracnose caused by *Colletotrichum karstii* on tea-oil trees (*Camellia oleifera*) in China. *Plant Dis* 102:674. <https://doi.org/10.1094/PDIS-08-17-1195-PDN>
- Johnston PR, Jones D (1997) Relationships among *Colletotrichum* isolates from fruit-rots assessed using rDNA sequences. *Mycologia* 89:420–430. <https://doi.org/10.1080/00275514.1997.12026801>
- Joshee S, Paulus BC, Park D, Johnston PR (2009) Diversity and distribution of fungal foliar endophytes in New Zealand Podocarpaceae. *Mycol Res* 113:1003–1015. <https://doi.org/10.1016/j.mycres.2009.06.004>
- Juárez-Vázquez SB, Silva-Rojas HV, Rebollar-Alviter A, Maidana-Ojeda M, Osnaya-González M, Fuentes-Aragón D (2019) Phylogenetic and morphological identification of *Colletotrichum godetiae*, a novel pathogen causing anthracnose on loquat fruits (*Eriobotrya japonica*). *J Plant Dis Protect* 126:593–598. <https://doi.org/10.1007/s41348-019-00264-2>
- Kanto T, Uematsu S, Tsukamoto T, Moriwaki J, Yamagishi N, Usami T, Sato T (2014) Anthracnose of sweet pepper caused by *Colletotrichum scovillei* in Japan. *J Gen Plant Pathol* 80:73–78. <https://doi.org/10.1007/s10327-013-0496-9>
- Karimi K, Khodaei S, Rota-Stabelli O, Arzanlou M, Pertot I (2016) Identification and characterization of two new fungal pathogens of *Polygonatum odoratum* (Angular Solomon's seal) in Italy. *J Phytopathol* 164:1075–1084. <https://doi.org/10.1111/jph.12528>
- Karimi O, Tajick Ghanbari MA, Bagherabadi S, Moradi Amirabad Y (2017) First report of *Colletotrichum sansevieriae* causing anthracnose on *Sansevieria trifasciata* in Iran. *J Plant Pathol* 99:302. <https://doi.org/10.4454/jpp.v99i1.3840>
- Kasson MT, Pollok JR, Benhase EB, Jelesko JG (2014) First report of seedling blight of eastern poison ivy (*Toxicodendron radicans*) by *Colletotrichum fioriniae* in Virginia. *Plant Dis* 98:995. <https://doi.org/10.1094/PDIS-09-13-0946-PDN>
- Katoch M, Paul A, Singh G, Sridhar SNC (2017) Fungal endophytes associated with *Viola odorata* Linn. as bioresource for pancreatic lipase inhibitors. *BMC Complement Altern Med* 17:385. <https://doi.org/10.1186/s12906-017-1893-y>
- Katoh K, Standley DM (2013) MAFFT Multiple Sequence Alignment Software Version 7: improvements in performance and usability. *Mol Biol Evol* 30:772–780. <https://doi.org/10.1093/molbev/mst010>
- Kee YJ, Zakaria L, Mohd MH (2020) Identification, pathogenicity and histopathology of *Colletotrichum sansevieriae* causing anthracnose of *Sansevieria trifasciata* in Malaysia. *J Appl Microbiol* 129:626–636. <https://doi.org/10.1111/jam.14640>
- Kemei L, Wenjing H, Dou XL, Fan JX, Yang H (2021) First report of Alfalfa Anthracnose caused by *Colletotrichum americanae-borealis* in Xinjiang, China. *Plant Dis*. <https://doi.org/10.1094/PDIS-01-21-0138-PDN> ((in press))
- Khodaei S, Arzanlou M, Torbati M, Eghbali S (2019) Novel hosts in the genus *Colletotrichum* and first report of *C. higginsianum* from Iran. *Nova Hedwig* 108:449–463. https://doi.org/10.1127/nova_hedwigia/2018/0510
- Kim GH, Choi DH, Park SY, Koh YJ (2018) First report of Anthracnose caused by *Colletotrichum nymphaeae* on Kiwiberry in Korea. *Plant Dis* 102:1455. <https://doi.org/10.1094/PDIS-11-17-1768-PDN>
- Kim JS, Hassan O, Go MJ, Chang T (2021) First report of *Colletotrichum aenigma* causing Anthracnose of grape (*Vitis vinifera*) in Korea. *Plant Dis*. <https://doi.org/10.1094/pdis-11-20-2458-pdn> ((in press))
- Kong WL, Wu SH, Wu XQ, Zheng XR, Sun XR, Ye JN, Wang QH (2020) First report of leaf spot disease caused by *Colletotrichum tropicale* on *Ficus binnendijkii* var. *variegata* in China. *Plant Dis* 104:585. <https://doi.org/10.1094/PDIS-04-19-0834-PDN>
- Kou LP, Gaskins V, Luo YG, Jurick WM II (2014) First report of *Colletotrichum fioriniae* causing postharvest decay on 'Nittany' apple fruit in the United States. *Plant Dis* 98:993. <https://doi.org/10.1094/PDIS-08-13-0816-PDN>
- Kumar S, Stecher G, Tamura K (2016) MEGA7: Molecular Evolutionary Genetics Analysis Version 7.0 for bigger datasets. *Mol Biol Evol* 33:1870–1874. <https://doi.org/10.1093/molbev/msw054>
- Kumar VS, Nair BA, Nair PVR, Annamalai A, Jaishanker R, Umamaheswaran K, Sooraj NP, Peethambaran CK (2017) First report of *Colletotrichum siamense* causing Anthracnose of cliff banana in India. *Plant Dis* 101:390. <https://doi.org/10.1094/PDIS-07-16-0961-PDN>

- Kunta M, Park J-W, Vedasharan P, Graça JV, Terry MD (2018) First report of *Colletotrichum queenslandicum* on Persian lime causing leaf Anthracnose in the United States. *Plant Dis* 102:677. <https://doi.org/10.1094/PDIS-09-17-1382-PDN>
- Kurt Ş, Uysal A, Akgül DS (2016) First report of Anthracnose caused by *Colletotrichum spinaciae* on Spinach in the Mediterranean region of Turkey. *Plant Dis* 100:219. <https://doi.org/10.1094/PDIS-04-15-0488-PDN>
- Kwon J-H, Kim J (2013) First report of Anthracnose on *Rohdea japonica* caused by *Colletotrichum liriopes* in Korea. *Plant Dis* 97:559. <https://doi.org/10.1094/PDIS-08-12-0801-PDN>
- Kwon JH, Kim J, Choi O, Gang G-H, Han S, Kwak Y-S (2013) Anthracnose caused by *Colletotrichum horii* on sweet persimmon in Korea: dissemination of conidia and disease development. *J Phytopathol* 161:497–502. <https://doi.org/10.1111/jph.12096>
- Kwon J-H, Choi O, Lee Y, Kim S, Kang B, Kim J (2020) Anthracnose on postharvest avocado caused by *Colletotrichum kahawae* subsp. *ciggaro* in South Korea. *Can J Plant Pathol* 42:508–513. <https://doi.org/10.1080/07060661.2019.1696891>
- Lan CZ, Yu DY, Yao JA, Ruan HC (2016) First report of Anthracnose on *Dendrobium officinale* Kimura et Migo caused by *Colletotrichum gloeosporioides* in China. *Plant Dis* 100:226. <https://doi.org/10.1094/PDIS-02-15-0151-PDN>
- Lardner R, Johnston PR, Plummer KM, Pearson MN (1999) Morphological and molecular analysis of *Colletotrichum acutatum* sensu lato. *Mycol Res* 103:275–285. <https://doi.org/10.1017/S0953756298007023>
- Larran S, Bahima JV, Dal Bello G, Franco E, Balatti P (2015) *Colletotrichum siamense* causing Anthracnose in *Bauhinia forficata* subsp. *pruinosa* in Argentina. *Australas Plant Dis Notes* 10:7. <https://doi.org/10.1007/s13314-015-0160-7>
- Lee S-Y, Jung H-Y (2018) *Colletotrichum kakivorum* sp. nov., a new leaf spot pathogen of persimmon in Korea. *Mycol Prog* 17:1113–1121. <https://doi.org/10.1007/s11557-018-1424-3>
- Lee D, Hassan O, Kim C, Chang T (2018) First report of peach (*Prunus persica*) Anthracnose caused by *Colletotrichum fioriniae* in Korea. *Plant Dis* 102:2650. <https://doi.org/10.1094/PDIS-05-18-0716-PDN>
- Lelwala RV, Scott JB, Ades PK, Taylor PWJ (2019) Population structure of *Colletotrichum tanacetii* in Australian pyrethrum reveals high evolutionary potential. *Phytopathology* 109:1779–1792. <https://doi.org/10.1094/PHYTO-03-19-0091-R>
- Li SZ, Li H (2020) First report of *Colletotrichum nymphaeae* causing Anthracnose on *Camellia oleifera* in China. *Plant Dis* 104:1860. <https://doi.org/10.1094/PDIS-09-19-2016-PDN>
- Li Z, Liang YM, Tian CM (2012) Characterization of the causal agent of poplar anthracnose occurring in the Beijing region. *Mycotaxon* 120:277–286. <https://doi.org/10.5248/120.277>
- Li QL, Mo JY, Huang SP, Guo TX, Pan ZB, Ning P, Hsiang T (2013) First report of leaf spot disease caused by *Glomerella magna* on *Lobelia chinensis* in China. *Plant Dis* 97:1383. <https://doi.org/10.1094/PDIS-03-13-0346-PDN>
- Li PL, Liu D, Zheng XJ, Chen HB, Gong GS, Zhang M, Wang XG (2016a) First report of *Colletotrichum gloeosporioides* causing Anthracnose on *Bauhinia blakeana*. *Plant Dis* 100:2165. <https://doi.org/10.1094/PDIS-03-16-0367-PDN>
- Li PL, Liu D, Yan JM, Qin Y, Yang XX (2016b) First report of *Colletotrichum gloeosporioides* causing anthracnose on *Elaeocarpus sylvestris* in Sichuan Province of China. *Plant Dis* 100:524. <https://doi.org/10.1094/PDIS-05-15-0519-PDN>
- Li GJ, Hyde KD, Zhao RL, Hongsanan S, Abdel-Aziz FA, Abdel-Wahab MA, Alvarado P, Alves-Silva G, Ammirati JF, Ariyawansa HA, Baghela A, Bahkali AH, Beug M, Bhat DJ, Bojantchev D, Boonpratuang T, Bulgakov TS, Camporesi E, Boro MC, Ceska O, Chakraborty D, Chen JJ, Chethana KWT, Chomnunti P, Consiglio G, Cui B-K, Dai DQ, Dai YC, Daranagama DA, Das K, Dayarathne MC, De Crop E, De Oliveira RJV, de Souza CAF, de Souza JI, Dentinger BTM, Dissanayake AJ, Doilom M, Drechsler-Santos ER, Ghobad-Nejhad M, Gilmore SP, Góes-Neto A, Gorczak M, Haitjema CH, Hapuarachchi KK, Hashimoto A, He MQ, Henske JK, Hirayama K, Iribarren MJ, Jayasiri SC, Jayawardena RS, Jeon SJ, Jerônimo GH, Jesus AL, Jones EBG, Kang JC, Karunarathna SC, Kirk PM, Konta S, Kuhnert E, Langer E, Lee HS, Lee HB, Li WJ, Li XH, Liimatainen K, Lima DX, Lin CG, Liu JK, Liu XZ, Liu ZY, Luangsa-ard JJ, Lücking R, Lumbsch HT, Lumyong S, Leaño EM, Marano AV, Matsumura M, McKenzie EHC, Mongkolsamrit S, Mortimer PE, Nguyen TTT, Niskanen T, Norphanphou C, O'Malley MA, Parnmen S, Pawłowska J, Perera RH, Phookamsak R, Phukhamsakda C, Pires-Zottarelli CLA, Raspé O, Reck MA, Rocha SCO, Santiago ALCMA, Senanayake IC, Setti L, Shang QJ, Singh SK, Sir EB, Solomon KV, Song J, Srikitikulchai P, Stadler M, Suetrong S, Takahashi H, Takahashi T, Tanaka K, Tang LP, Thambugala KM, Thanakitpipattana D, Theodorou MK, Thongbai B, Thummarukcharoen T, Tian Q, Tibpromma S, Verbeken A, Vizzini A, Vlasák J, Voigt K, Wanasinghe DN, Wang Y, Weerakoon G, Wen HA, Wen TC, Wijayawardene NN, Wongkanoun S, Wrzosek M, Xiao YP, Xu JC, Yan JY, Yang J, Yang SD, Hu Y, Zhang JF, Zhao J, Zhou LW, Peršoh D, Phillips AJL, Maharachchikumbura SSN (2016c) Fungal diversity notes 253–366: taxonomic and phylogenetic contributions to fungal taxa. *Fungal Divers* 78:1–237. <https://doi.org/10.1007/s13225-016-0366-9>
- Li Q, Mo J, Guo T, Huang S, Tang L, Ning P, Notay K, Hsiang T (2016d) First report of leaf spot of *Curcuma wenyujin* caused by *Colletotrichum curcumae* in China. *Plant Dis* 100:521. <https://doi.org/10.1094/PDIS-06-15-0699-PDN>
- Li L, Pan H, Chen MY, Zhang SJ, Zhong CH (2017a) First report of Anthracnose caused by *Colletotrichum gloeosporioides* on Kiwifruit (*Actinidia chinensis*) in China. *Plant Dis* 101:2151. <https://doi.org/10.1094/PDIS-06-17-0861-PDN>
- Li J, Li PL, Wang YQ, Liu D, Gong GS, Yan JM (2017b) First report of *Colletotrichum gloeosporioides* causing Anthracnose on *Cherospondias axillaris* in Sichuan Province of China. *Plant Dis* 101:1036. <https://doi.org/10.1094/PDIS-01-17-0113-PDN>
- Li YL, Yan ZB, Wang YH, Lin QK, Wang SB, Zhou Z (2018a) First report of *Colletotrichum karstii* causing Anthracnose on lotus bamboo (*Dracaena sanderiana*) in China. *Plant Dis* 102:2641. <https://doi.org/10.1094/PDIS-04-18-0579-PDN>
- Li YL, Zhou Z, Yan ZB (2018b) First report of *Colletotrichum karstii* causing Anthracnose on *Nandina domestica* in Henan Province. *China Plant Dis* 102:444. <https://doi.org/10.1094/PDIS-07-17-0974-PDN>
- Li H, Zhou GY, Qi XY, Jiang SQ (2018c) First report of *Colletotrichum henanense* causing Anthracnose on tea-oil trees in China. *Plant Dis* 102:1040. <https://doi.org/10.1094/PDIS-08-17-1302-PDN>
- Li L, Mohd MH, Zakaria L (2019a) *Colletotrichum* species associated with mango (*Mangifera indica* L.) stem-end rot. *J Plant Pathol* 102:505–509. <https://doi.org/10.1007/s42161-019-00439-8>
- Li Q, Bu J, Shu J, Yu Z, Tang L, Huang S, Guo T, Mo J, Luo S, Solangi GS, Hsiang T (2019b) *Colletotrichum* species associated with mango in southern China. *Sci Rep* 9:18891. <https://doi.org/10.1038/s41598-019-54809-4>
- Li XY, Wang QH, Fan SS, Feng PB, Yang YH, Zhang XY, Liu ZY (2019c) First report of *Colletotrichum gloeosporioides* causing Anthracnose on *Sorbaria sorbifolia* in China. *Plant Dis* 103:1413. <https://doi.org/10.1094/PDIS-06-18-1011-PDN>
- Li Y, Ma X, Gai W-X, Xiao L-D, Gong Z-H (2021) First report of *Colletotrichum gloeosporioides* causing Anthracnose on pepper in Shaanxi Province, China. *Plant Dis*. <https://doi.org/10.1094/pdis-01-21-0123-pdn> (in press)

- Liang X, Yao L, Kong Y, Li B, Hao X, Lin Y, Cao M, Dong Q, Zhang R, Rollins JA, Sun G (2021) Molecular dissection of perithecial mating line development in *Colletotrichum fruticicola*, a species with a nontypical mating system featured by plus-to-minus switch and plus-minus mediated sexual enhancement. *Appl Environ Microbiol* 87(12):e00474–21. <https://doi.org/10.1128/aem.00474-21>
- Lichtemberg PSF, Moral J, Morgan DP, Felts DG, Sanders RD, Michailides TJ (2017) First report of Anthracnose caused by *Colletotrichum fioriniae* and *C. karstii* in California Pistachio Orchards. *Plant Dis* 101:1320. <https://doi.org/10.1094/PDIS-01-17-0144-PDN>
- Lima NB, Batista MVA, Morais MA Jr, Barbosa MAG, Michereff SJ, Hyde KD, Câmara MPS (2013) Five *Colletotrichum* species are responsible for mango anthracnose in northeastern Brazil. *Fungal Divers* 61:75–88. <https://doi.org/10.1007/s13225-013-0237-6>
- Lima NB, Pastor SE, Maza CE, Conforto C, Vargas-Gil S, Roca M (2020) First report of Anthracnose of olive fruit caused by *Colletotrichum theobromicola* in Argentina. *Plant Dis* 104:589. <https://doi.org/10.1094/PDIS-06-19-1207-PDN>
- Lin S, Taylor NJ, Hand FP (2018a) Identification and characterization of fungal pathogens causing fruit rot of deciduous holly. *Plant Dis* 102:2430–2445. <https://doi.org/10.1094/PDIS-02-18-0372-RE>
- Lin C-H, Wu W-Q, Liao X-M, Liu W-B, Miao W-G, Zheng F-C (2018b) First report of leaf Anthracnose caused by *Colletotrichum alatae* on Water Yam (*Dioscorea alata*) in China. *Plant Dis* 102:248. <https://doi.org/10.1094/PDIS-07-17-0979-PDN>
- Lin C-H, Long X-P, Li Z-P, Zhang Y, He J-J, Liu W-B, Miao W-G (2020) First report of Anthracnose of *Clausena lansium* caused by *Colletotrichum scovillei* in China. *Plant Dis* 104:1557. <https://doi.org/10.1094/PDIS-08-19-1765-PDN>
- Ling J-F, Peng A-T, Jiang Z-D, Xi P-G, Song X-B, Cheng B-P, Cui Y-P, Chen X (2021) First report of Anthracnose fruit rot caused by *Colletotrichum fioriniae* on Litchi in China. *Plant Dis* 105:1225. <https://doi.org/10.1094/pdis-07-20-1539-pdn>
- Lisboa DO, Silva MA, Pinho DB, Pereira OL, Furtado GQ (2018) Diversity of pathogenic and endophytic *Colletotrichum* isolates from *Licania tomentosa* in Brazil. *For Pathol* 48:e12448. <https://doi.org/10.1111/efp.12448>
- Liu X, Xie X, Duan J (2007) *Colletotrichum yunnanense* sp. nov., a new endophytic species from *Buxus* sp. *Mycotaxon* 100:137–144
- Liu F, Hyde KD, Cai L (2011) Neotypification of *Colletotrichum coccodes*, the causal agent of potato black dot disease and tomato anthracnose. *Mycology* 2:248–254. <https://doi.org/10.1080/21501203.2011.600342>
- Liu F, Damm U, Cai L, Crous PW (2013a) Species of the *Colletotrichum gloeosporioides* complex associated with anthracnose diseases of Proteaceae. *Fungal Divers* 61:89–105. <https://doi.org/10.1007/s13225-013-0249-2>
- Liu F, Cai L, Crous PW, Damm U (2013b) Circumscription of the anthracnose pathogens *Colletotrichum lindemuthianum* and *C. nigrum*. *Mycologia* 105:844–860. <https://doi.org/10.3852/12-315>
- Liu F, Cai L, Crous PW, Damm U (2014) The *Colletotrichum gigasporum* species complex. *Persoonia* 33:83–97. <https://doi.org/10.3767/003158514X684447>
- Liu F, Weir BS, Damm U, Crous PW, Wang Y, Liu B, Wang M, Zhang M, Cai L (2015a) Unravelling *Colletotrichum* species associated with *Camellia*: employing ApMat and GS loci to resolve species in the *C. gloeosporioides* complex. *Persoonia* 35:63–86. <https://doi.org/10.3767/003158515X687597>
- Liu JK, Hyde KD, Jones EBG, Ariyawansa HA, Bhat DJ, Boonmee S, Maharachchikumbura SSN, McKenzie EHC, Phookamsak R, Phukhamsakda C, Shenoy BD, Abdel-Wahab MA, Buyck B, Chen J, Chethana KWT, Singtripop C, Dai DQ, Dai YC, Daranagama DA, Dissanayake AJ, Doilom M, D'Souza MJ, Fan XL, Goonasekara ID, Hirayama K, Hongsanan S, Jayasiri SC, Jayawardena RS, Karunarathna SC, Li WJ, Mapook A, Norphanphou C, Pang KL, Perera RH, Peršoh D, Pinruan U, Senanayake IC, Somrithipol S, Suetrong S, Tanaka K, Thambugala KM, Tian Q, Tibpromma S, Udayanga D, Wijayawardene NN, Wanasinghe D, Wisitrassameewong K, Zeng XY, Abdel-Aziz FA, Adamčík S, Bahkali AH, Boonyuen N, Bulgakov T, Callac P, Chomnunti P, Greiner K, Hashimoto A, Hofstetter V, Kang JC, Lewis D, Li XH, Liu XZ, Liu ZY, Matsumura M, Mortimer PE, Rambold G, Randrianjohany E, Sato G, Sri-Indrasutdhi V, Tian CM, Verbeke A, von Brackel W, Wang Y, Wen TC, Xu JC, Yan JY, Zhao RL, Camporesi E (2015b) Fungal diversity notes 1–110: taxonomic and phylogenetic contributions to fungal species. *Fungal Divers* 72:1–197. <https://doi.org/10.1007/s13225-015-0324-y>
- Liu LP, Yang LY, Liu YN, Yang LN, Lu BH, Yu L, Jin XS, Wang X, Yang C, Li Y, Gao J, Hsiang T (2016a) First report of Anthracnose disease caused by *Colletotrichum fioriniae* on Barbary Wolfberry in China. *Plant Dis* 100:2534. <https://doi.org/10.1094/PDIS-06-16-0930-PDN>
- Liu M, Zhang W, Zhou Y, Liu Y, Yan JY, Li XH, Jayawardena RS, Hyde KD (2016b) First report of twig Anthracnose on Grapevine caused by *Colletotrichum nymphaeae* in China. *Plant Dis* 100:2530. <https://doi.org/10.1094/PDIS-05-16-0632-PDN>
- Liu F, Tang G, Zheng X, Li Y, Sun X, Qi X, Zhou Y, Xu J, Chen H, Chang X, Zhang S, Gong G (2016c) Molecular and phenotypic characterization of *Colletotrichum* species associated with Anthracnose disease in peppers from Sichuan Province. *China Sci Rep* 6:32761. <https://doi.org/10.1038/srep32761>
- Liu LP, Jin XS, Yu L, Lu BH, Liu YN, Yang LY, Liu ZH, Li Y, Gao J, Hsiang T (2016d) *Colletotrichum dematium*: causing Anthracnose on common Knotgrass (*Polygonum aviculare*) in China. *Plant Dis* 100:1240. <https://doi.org/10.1094/PDIS-10-15-1161-PDN>
- Liu D, Li PL, Li J, Luo X, Gong GS, Zhang M, Yan JM, Huang Y, Wang Q (2017a) First report of *Colletotrichum siamense* causing Anthracnose on *Iris tectorum* in Sichuan Province of China. *Plant Dis* 101:2150. <https://doi.org/10.1094/PDIS-07-17-1029-PDN>
- Liu LP, Liu YN, Yang LY, Lu BH, Yang LN, Wang X, Li Y, Gao J, Hsiang T (2017b) First report of Anthracnose caused by *Colletotrichum destructivum* on curly dock in China. *Plant Dis* 101:256. <https://doi.org/10.1094/PDIS-08-16-1084-PDN>
- Liu LP, Liu YN, Yang LY, Lu BH, Nan N, Li Y, Gao J, Hsiang T (2017c) First report of leaf and stem Anthracnose caused by *Colletotrichum trifolii* on Cluster Mallow (*Malva crispa*) in China. *Plant Dis* 101:251. <https://doi.org/10.1094/PDIS-06-16-0936-PDN>
- Liu T, Chen D, Liu Z, Hou JM (2018) First report of Anthracnose caused by *Colletotrichum tropicale* on *Sauropus androgynus* in China. *Plant Dis* 102:2030. <https://doi.org/10.1094/PDIS-12-17-1959-PDN>
- Liu X, Shi T, Li B, Cai J, Li C, Huang G (2019a) *Colletotrichum* species associated with cassava anthracnose in China. *J Phytopathol* 167:1–9. <https://doi.org/10.1111/jph.12765>
- Liu YL, Lu JN, Zhou YH (2019b) First report of *Colletotrichum truncatum* causing Anthracnose of lucky bamboo in Zhanjiang. *China Plant Dis* 103:2947. <https://doi.org/10.1094/PDIS-05-19-1122-PDN>
- Liu XB, Yanli F, Xiaolan Z, Huang GX (2019c) First report of papaya Anthracnose caused by *Colletotrichum brevisporum* in China. *Plant Dis* 103:2473. <https://doi.org/10.1094/PDIS-03-19-0539-PDN>
- Liu HN, Liu JA, Zhou GY (2020a) First report of *Colletotrichum alienum* causing Anthracnose on *Aquilaria sinensis* in China. *Plant Dis* 104:283. <https://doi.org/10.1094/PDIS-01-19-0155-PDN>

- Liu L, Zhang L, Qiu P, Wang Y, Liu Y, Li Y, Gao J, Hsiang T (2020b) Leaf spot of *Polygonatum odoratum* caused by *Colletotrichum spaethianum*. *J Gen Plant Pathol* 86:157–161. <https://doi.org/10.1007/s10327-019-00903-4>
- Liu L-P, Wang Y, Qiu P-L, Zhang B, Zhang L, Wang N, Li Y, Gao J, Hsiang T (2020c) *Colletotrichum neorubicola* sp. nov., a new leaf anthracnose pathogen of raspberry from northeast China. *Mycol Prog* 19:947–955. <https://doi.org/10.1007/s11557-020-01614-3>
- Liu Y, An F, Zhang Y, Fu C, Su Y (2021a) First report of Anthracnose on Jerusalem cherry caused by *Colletotrichum liaoningense* in Shandong, China. *Plant Dis*. <https://doi.org/10.1094/pdis-01-21-0124-pdn> (in press)
- Liu B, Pavel JA, Hausbeck MK, Feng CD, Correll JC (2021b) Phylogenetic analysis, vegetative compatibility, virulence, and fungal filtrates of leaf curl pathogen *Colletotrichum fioriniae* from Celery. *Phytopathology* 111:751–760. <https://doi.org/10.1094/PHYTO-04-20-0123-R>
- Liu L, Zhang YJ, Guo LZ, Xu LL (2021c) First report of *Colletotrichum gloeosporioides* causing leaf spot on *Cyclobalanopsis glauca* in China. *Plant Dis*. <https://doi.org/10.1094/pdis-11-20-2374-pdn> (in press)
- Lopes LHR, Boiteux LS, Rossato M, Aguiar FM, Fonseca MEN, Oliveira VR, Reis A (2021) Diversity of *Colletotrichum* species causing onion anthracnose in Brazil. *Eur J Plant Pathol* 159:339–357. <https://doi.org/10.1007/s10658-020-02166-8>
- López-Moral A, Raya-Ortega MC, Agustí-Brisach C, Roca LF, Lovera M, Luque F, Arquero O, Trapero A (2017) Morphological, pathogenic, and molecular characterization of *Colletotrichum acutatum* isolates causing almond Anthracnose in Spain. *Plant Dis* 101:2034–2045. <https://doi.org/10.1094/PDIS-03-17-0318-RE>
- Lu Q, Wang Y, Li N, Ni D, Yang Y, Wang X (2018) Differences in the characteristics and pathogenicity of *Colletotrichum camelliae* and *C. fructicola* isolated from the tea plant [*Camellia sinensis* (L.) O. Kuntze]. *Front Microbiol* 9:3060. <https://doi.org/10.3389/fmicb.2018.03060>
- Lücking R, Aime MC, Robbertse B, Miller AN, Ariyawansa HA, Aoki T, Cardinali G, Crous PW, Druzhinina IS, Geiser DM, Hawksworth DL, Hyde KD, Iriny L, Jeewon R, Johnston PR, Kirk PM, Malosso E, May TW, Meyer W, Öpik M, Robert V, Stadler M, Thines M, Vu D, Yurkov AM, Zhang N, Schoch CL (2020) Unambiguous identification of fungi: where do we stand and how accurate and precise is fungal DNA barcoding? *IMA Fungus* 11:14. <https://doi.org/10.1186/s43008-020-00033-z>
- Ma X, Nontachaiyapoom S, Jayawardena RS, Hyde KD, Gentekaki E, Zhou S, Qian Y, Wen T, Kang J (2018) Endophytic *Colletotrichum* species from *Dendrobium* spp. in China and Northern Thailand. *Mycology* 43:23–57. <https://doi.org/10.3897/mycol.43.25081>
- Ma J, Xiao X, Wang X, Guo M (2021) *Colletotrichum spaethianum* causing Anthracnose on *Polygonatum cyrtonema* Hua in Anhui Province. *China Plant Dis* 105:509. <https://doi.org/10.1094/PDIS-04-20-0778-PDN>
- Macedo DM, Barreto RW (2016) *Colletotrichum dracaenophilum* causes anthracnose on *Dracaena braunii* in Brazil. *Australas Plant Dis Notes* 11:5. <https://doi.org/10.1007/s13314-016-0192-7>
- Macedo DM, Pereira OL, Hora Júnior BT, Weir BS, Barreto RW (2016) Mycobiota of the weed *Tradescantia fluminensis* in its native range in Brazil with particular reference to classical biological control. *Australas Plant Pathol* 45:45–56. <https://doi.org/10.1007/s13313-015-0388-x>
- Machado SCS, Veloso JS, Câmara MPS, Campos F, Sarmiento RA, Giongo MV, Santos GR (2021a) First report of *Colletotrichum chrysophyllum* causing cassava Anthracnose in Brazil. *Plant Dis* 105:1196. <https://doi.org/10.1094/pdis-09-20-1925-pdn>
- Machado SCS, Vieira WAS, Duarte UG, Amaral AG, Veloso JS, Câmara MPS, Santos GR (2021b) First report of *Colletotrichum truncatum* causing anthracnose in cassava in Brazil. *Plant Dis*. <https://doi.org/10.1094/PDIS-03-21-0571-PDN> (in press)
- Mahadevakumar S, Chandana C, Janardhana GR (2019) First report of *Colletotrichum truncatum* associated with anthracnose disease on tuberose (*Polianthes tuberosa*) in India. *Crop Protect* 118:1–5. <https://doi.org/10.1016/j.cropro.2018.12.006>
- Mahmodi F, Kadir JB, Nasehi A, Puteh A, Soleimani N (2013) Occurrence of Anthracnose caused by *Colletotrichum truncatum* on chickpea (*Cicer arietinum*) in Malaysia. *Plant Dis* 97:1507. <https://doi.org/10.1094/PDIS-03-13-0231-PDN>
- Manamgoda DS, Udayanga D, Cai L, Chukeatirote E, Hyde KD (2013) Endophytic *Colletotrichum* from tropical grasses with a new species *C. endophytica*. *Fungal Divers* 61:107–115. <https://doi.org/10.1007/s13225-013-0256-3>
- Mangwende E, Chirwa PW, Aveling TAS (2020) Evaluation of seed treatments against *Colletotrichum kahawae* subsp. *cigarro* on *Eucalyptus* spp. *Crop Protect* 132:105113. <https://doi.org/10.1016/j.cropro.2020.105113>
- Marcelino J, Giordano R, Gouli S, Gouli V, Parker BL, Skinner M, TeBeest D, Cesnik R (2008) *Colletotrichum acutatum* var. *fioriniae* (teleomorph: *Glomerella acutata* var. *fioriniae* var. nov.) infection of a scale insect. *Mycologia* 100:353–374. <https://doi.org/10.3852/07-174R>
- Marín-Felix Y, Groenewald JZ, Cai L, Chen Q, Marincowitz S, Barnes I, Bensch K, Braun U, Camporesi E, Damm U, de Beer ZW, Dissanayake A, Edwards J, Giraldo A, Hernández-Restrepo M, Hyde KG, Jayawardena RS, Lombard L, Luangsa-ard J, McTaggart AR, Rossman AY, Sandoval-Denis M, Shen M, Shivas RG, Tan YP, van der Linde EJ, Wingfield MJ, Wood AT, Zhang JQ, Zhang Y, Crous PW (2017) Genera of phytopathogenic fungi: GOPHY 1. *Stud Mycol* 86:99–216. <https://doi.org/10.1016/j.simyco.2017.04.002>
- Martins MVV, Lima JS, Araújo FSA, Ootani MA, Viana FMP, Cardoso JE, Coutinho IBL, Gonçalves FJT, Fonseca WL (2018) First report of *Colletotrichum theobromicola* causing leaf spot in sapote (*Manilkara zapota*) seedlings in Brazil. *Plant Dis* 102:2641. <https://doi.org/10.1094/PDIS-04-18-0587-PDN>
- Mascarin GM, Guarín-Molina JH, Arthurs SP, Humber RA, Moral RA, Demétrio CGB, Delalibera Í Jr (2016) Seasonal prevalence of the insect pathogenic fungus *Colletotrichum nymphaeae* in Brazilian citrus groves under different chemical pesticide regimes. *Fungal Ecol* 22:43–51. <https://doi.org/10.1016/j.funeco.2016.04.005>
- Matos KS, Santana KFA, Catarino AM, Hanada RE, Silva GF (2017) First report of Anthracnose on welsh onion (*Allium fistulosum*) in Brazil caused by *Colletotrichum theobromicola* and *C. truncatum*. *Plant Dis* 101:1055. <https://doi.org/10.1094/PDIS-10-16-1494-PDN>
- Matos KS, Machado JF, Chagas PC, Siqueira RHS, Silva GF, Xavier Filha MS, Lima-Primo HE, Chagas EA (2020) First report of *Colletotrichum aeschnomenes* and *C. tropicale* causing Anthracnose on *Myrciaria dubia* in Brazil. *Plant Dis* 104:2517. <https://doi.org/10.1094/PDIS-04-19-0882-PDN>
- May TW, Cooper JA, Dahleberg A, Furci G, Minter DW, Mueller GM, Pouliot A, Yang Z (2018) Recognition of the discipline of conservation mycology. *Conserv Biol* 33:733–736. <https://doi.org/10.1111/cobi.13228>
- McCulloch MJ, Gauthier NW, Vaillancourt LJ (2020) First report of bitter rot of apple caused by a *Colletotrichum* sp. in the *C. kahawae* clade in Kentucky. *Plant Dis* 104:289. <https://doi.org/10.1094/PDIS-06-19-1247-PDN>
- Meetum P, Leksomboon C, Kanjanamaneesathian M (2015) First report of *Colletotrichum aenigma* and *C. siamense*, the causal agent of anthracnose disease of dragon fruit in Thailand. *J Plant Pathol* 97:402. <https://doi.org/10.4454/JPP.V97I2.048>
- Menat J, Armstrong-Cho C, Banniza S (2016) Lack of evidence for sexual reproduction in field populations of *Colletotrichum*

- lentis*. Fungal Ecol 20:66–74. <https://doi.org/10.1016/j.funeco.2015.11.001>
- Meneses PR, Dorneles KR, Bellé C, Moreira-Nuñez VL, Gaviria-Hernández V, Farias CRJ (2019) Detection of *Colletotrichum boninense* causing leaf Anthracnose on *Alcantarea imperialis* in Brazil. Plant Dis 103:2125. <https://doi.org/10.1094/PDIS-02-19-0410-PDN>
- Miao XY, Liu LP, Yang LN, Bai QR (2017) First report of Anthracnose on *Cynanchum atratum* caused by *Colletotrichum destructivum* in China. Plant Dis 101:252. <https://doi.org/10.1094/PDIS-07-16-1003-PDN>
- Mincuzzi A, Ippolito A, Sanzani SM (2017) First report of *Colletotrichum acutatum* sensu stricto causing postharvest rot on pomegranate fruit in Italy. J Plant Pathol 99:818. <https://doi.org/10.4454/jpp.v99i3.3994>
- Mio LLM, Silva FA, Blood RY, Figueiredo JAG (2015) Twig blight and defoliation caused by *Colletotrichum horii* in persimmons in Brazil. Rev Bras Frutic 37:256–260. <https://doi.org/10.1590/0100-2945-044/14>
- Moreira RR, Peres NA, Mio LLM (2019a) *Colletotrichum acutatum* and *C. gloeosporioides* species complexes associated with apple in Brazil. Plant Dis 103:268–275. <https://doi.org/10.1094/PDIS-07-18-1187-RE>
- Moreira RR, Vandresen DP, Glienke C, May-De-Mio LL (2019b) First report of *Colletotrichum nymphaeae* causing blossom blight, peduncle rot, and fruit rot on *Pyrus pyrifolia* in Brazil. Plant Dis 103:2133. <https://doi.org/10.1094/PDIS-12-18-2263-PDN>
- Moreira RR, Silva GA, May De Mio LL (2020) *Colletotrichum acutatum* complex causing anthracnose on peach in Brazil. Australas Plant Pathol 49:179–189. <https://doi.org/10.1007/s13313-020-00690-z>
- Moreira V, Mondino P, Alaniz S (2021) Olive anthracnose caused by *Colletotrichum* in Uruguay: symptoms, species diversity and pathogenicity on flowers and fruits. Eur J Plant Pathol 160:663–682. <https://doi.org/10.1007/s10658-021-02274-z>
- Moriwaki J, Tsukiboshi T (2009) *Colletotrichum echinochloae*, a new species on Japanese barnyard millet (*Echinochloa utilis*). Mycoscience 50:273–280. <https://doi.org/10.1007/S10267-009-0485-1>
- Moriwaki J, Sato T, Tsukiboshi T (2003) Morphological and molecular characterization of *Colletotrichum boninense* sp. nov. from Japan. Mycoscience 44:47–53. <https://doi.org/10.1007/S10267-002-0079-7>
- Morsy AA, Elshahawy IE (2016) Anthracnose of lucky bamboo *Dracaena sanderiana* caused by the fungus *Colletotrichum dracaenophilum* in Egypt. J Adv Res 7:327–335. <https://doi.org/10.1016/j.jare.2016.01.002>
- Mosca S, Nicosia MGD, Cacciola SO, Schena L (2014) Molecular analysis of *Colletotrichum* species in the carposphere and phyllosphere of olive. PLoS ONE 9:e114031. <https://doi.org/10.1371/journal.pone.0114031>
- Munda A (2014) First report of *Colletotrichum fioriniae* and *C. godeitiae* causing apple bitter rot in Slovenia. Plant Dis 98:1282. <https://doi.org/10.1094/PDIS-04-14-0419-PDN>
- Munir M, Amsden B, Dixon E, Vaillancourt L, Gauthier NAW (2016) Characterization of *Colletotrichum* species causing bitter rot of apple in Kentucky Orchards. Plant Dis 100:2194–2203. <https://doi.org/10.1094/PDIS-10-15-1144-RE>
- Naik T, Vanitha SC, Rajvanshi PK, Chandrika M, Kamalraj S, Jayabaskaran C (2018) Novel microbial sources of tropane alkaloids: first report of production by endophytic fungi isolated from *Datura metel* L. Curr Microbiol 75:206–212. <https://doi.org/10.1007/s00284-017-1367-y>
- Nakamura M, Ohzono M, Iwai H, Arai K (2006) Anthracnose of *Sansevieria trifasciata* caused by *Colletotrichum sansevieriae* sp. nov. J Gen Plant Pathol 72:253–256. <https://doi.org/10.1007/s10327-006-0280-1>
- Nascimento AD, Lima MO, Feijó FM, Júnior JH, Sobrinho RR, Assunção IP, Lima GSA (2019a) First report of *Colletotrichum aeshynomenes* causing Anthracnose in Cacao (*Theobroma cacao*) in Brazil. Plant Dis 103:3284. <https://doi.org/10.1094/PDIS-11-18-2047-PDN>
- Nascimento MB, Bellé C, Azambuja RM, Maich SLP, Neves CG, Souza-Junior IT, Jacobsen CRF, Barros DR (2019b) First report of *Colletotrichum karstii* causing Anthracnose spot on pitaya (*Hylocereus undatus*) in Brazil. Plant Dis 103:2137. <https://doi.org/10.1094/PDIS-02-19-0400-PDN>
- Naz F, Abbas MF, Rauf CA, Tariq A, Mumtaz A, Irshad G, Shaheen FA, Hassan I (2017) First report of *Colletotrichum gloeosporioides* causing Anthracnose on loquat in Pakistan. Plant Dis 101:1550. <https://doi.org/10.1094/PDIS-11-16-1551-PDN>
- Ngoc NK, Phong Nguyen NV, An PTM, Woolf AB, Fullerton RA (2018) Effect of storage temperatures on postharvest diseases of dragon fruit (*Hylocereus undatus* Haw.) in the Mekong Delta Region, Vietnam. Acta Hort 1213:453–460
- Ni HF, Huang CW, Wu CJ, Yang HR, Lin CY, Chang JY, Chang JW (2017) First report of pepper spot disease of lychee caused by *Colletotrichum siamense* in Taiwan. J Plant Pathol 99:808. <https://doi.org/10.4454/jpp.v99i3.3934>
- Ni H, Kong W-L, Zhang Q-Q, Wu X-Q (2021) First Report of leaf spot disease caused by *Colletotrichum gloeosporioides* on *Chaenomeles sinensis* in China. Plant Dis. <https://doi.org/10.1094/pdis-11-20-2488-pdn> ((in press))
- Nieto-López EH, Everhart SE, Ayala-Escobar V, Camacho-Tapia M, Lima NB, Nieto-Angel R, Tovar-Pedraza JM (2018) First report of *Colletotrichum gloeosporioides* causing Anthracnose of tejo-cote (*Crataegus gracilior*) fruits in Mexico. Plant Dis 102:1855. <https://doi.org/10.1094/PDIS-02-18-0233-PDN>
- Nikitin M, Deych K, Grevtseva I, Girsova N, Kuznetsova M, Pridanikov M, Dzhavakhiya V, Statsyuk N, Golikov A (2018) Preserved microarrays for simultaneous detection and identification of six fungal potato pathogens with the use of real-time PCR in matrix format. Biosensors 8:129. <https://doi.org/10.3390/bios8040129>
- Nirenberg HI, Feiler U, Hagedorn G (2002) Description of *Colletotrichum lupini* comb. nov. in modern terms. Mycologia 94:307–320. <https://doi.org/10.1080/15572536.2003.11833238>
- Niu XP, Gao H, Chen Y, Qi JM (2016a) First report of Anthracnose on White Jute (*Corchorus capsularis*) caused by *Colletotrichum fructicola* and *C. siamense* in China. Plant Dis 100:1243. <https://doi.org/10.1094/PDIS-12-15-1418-PDN>
- Niu XP, Gao H, Qi J, Chen M, Tao A, Xu J, Dai Z, Su J (2016b) *Colletotrichum* species associated with jute (*Corchorus capsularis* L.) anthracnose in southeastern China. Sci Rep 6:25179. <https://doi.org/10.1038/srep25179>
- Nodet P, Baroncelli R, Faugère D, Le Floch G (2016) First report of apple bitter rot caused by *Colletotrichum fioriniae* in Brittany. France Plant Dis 100:1497. <https://doi.org/10.1094/PDIS-11-15-1353-PDN>
- Noireung P, Phoulivong S, Liu F, Cai L, Mckenzie EHC, Chukeatirote E, Jones EBG, Bahkali AH, Hyde KD (2012) Novel species of *Colletotrichum* revealed by morphology and molecular analysis. Cryptogam Mycol 33:347–362. <https://doi.org/10.7872/crym.v33.iss3.2012.347>
- O'Connell RJ, Thon MR, Hacquard S, Amyotte SG, Kleemann J, Torres MF, Damm U, Buiate EA, Epstein L, Alkan N, Altmüller J, Alvarado-Balderrama L, Bauser CA, Becker C, Birren BW, Chen Z, Choi J, Crouch JA, Duvick JP, Farman MA, Gan P, Heiman D, Henrissat B, Howard RJ, Kabbage M, Koch C, Kracher B, Kubo Y, Law AD, Lebrun M-H, Lee Y-H, Miyara I, Moore N, Neumann U, Nordström K, Panaccione DG, Panstruga R, Place

- M, Proctor RH, Prusky D, Rech G, Reinhardt R, Rollins JA, Rounsley S, Schardl CL, Schwartz DC, Shenoy N, Shirasu K, Sikhakolli UR, Stüber K, Sukno SA, Sweigard JA, Takano Y, Takahara H, Trail F, van der Does HC, Voll LM, Will I, Young S, Zeng Q, Zhang J, Zhou S, Dickman MB, Schulze-Lefert P, van Themaat EVL, Ma LJ, Vaillancourt LJ (2012) Lifestyle transitions in plant pathogenic *Colletotrichum* fungi deciphered by genome and transcriptome analyses. *Nat Genet* 44:1060–1065. <https://doi.org/10.1038/ng.2372>
- Oh JY, Heo J-I, Lee D-H (2021) First report of Anthracnose on Pecan (*Carya illinoensis*) caused by *Colletotrichum siamense* in Korea. *Plant Dis*. <https://doi.org/10.1094/PDIS-12-20-2709-PDN> (in press)
- Okorley BA, Sossah FL, Dan D, Li Y, Fu Y (2019) First report of *Colletotrichum spaethianum* causing Anthracnose on *Anemarrhena asphodeloides* in China. *Plant Dis* 103:1414. <https://doi.org/10.1094/PDIS-09-18-1642-PDN>
- Okorski A, Puszczółkowska A, Sulima P, Pauksztó Ł, Jastrzębski JP, Przyborowski J, Makowczenko KG (2018) First report of Willow Anthracnose caused by *Colletotrichum salicis* in Poland. *Plant Dis* 102:2036. <https://doi.org/10.1094/PDIS-12-17-2023-PDN>
- Oliveira SAS, Bragança CAD, Silva LL (2016) First report of *Colletotrichum tropicale* causing Anthracnose on the wild cassava species *Manihot dichotoma* and *M. epruinosa* in Brazil. *Plant Dis* 100:2171. <https://doi.org/10.1094/PDIS-10-15-1136-PDN>
- Oliveira CVS, Matos KS, Albuquerque DMC, Hanada RE, Silva GF (2017) Identification of *Colletotrichum* isolates from *Capsicum chinense* in Amazon. *Genet Molec Res* 16:gmr16029601. <https://doi.org/10.4238/gmr16029601>
- Oliveira SAS, Silva LL, Diamantino MSAS, Ferreira CF (2018) First report of *Colletotrichum theobromicola* and *C. siamense* causing Anthracnose on cultivated and wild cassava species in Brazil. *Plant Dis* 102:819. <https://doi.org/10.1094/PDIS-09-17-1502-PDN>
- Oliveira SAS, Silva LL, Nascimento DS, Diamantino MSAS, Ferreira CF, Oliveira TAS (2020) *Colletotrichum* species causing cassava (*Manihot esculenta* Crantz) anthracnose in different eco-zones within the Recôncavo Region of Bahia, Brazil. *J Plant Dis Protect* 127:411–416. <https://doi.org/10.1007/s41348-020-00327-9>
- Oo MM, Oh S-K (2017a) Identification and characterization of new record of grape ripe rot disease caused by *Colletotrichum viniferum* in Korea. *Mycobiology* 45:421–425. <https://doi.org/10.5941/MYCO.2017.45.4.421>
- Oo MM, Oh S-K (2017b) New record of Anthracnose caused by *Colletotrichum liriopes* on broadleaf liriopie in Korea. *Korean J Mycol* 45:68–73. <https://doi.org/10.4489/KJM.20170008>
- Oo MM, Oh S-K (2020) First report of Anthracnose of chili pepper fruit caused by *Colletotrichum truncatum* in Korea. *Plant Dis* 104:564. <https://doi.org/10.1094/PDIS-09-19-1874-PDN>
- Oo MM, Tweneboah S, Oh S-K (2016) First report of Anthracnose caused by *Colletotrichum fioriniae* on Chinese matrimony vine in Korea. *Mycobiology* 44:325–329. <https://doi.org/10.5941/MYCO.2016.44.4.325>
- Oo MM, Lim GT, Jang HA, Oh S-K (2017) Characterization and pathogenicity of new record of Anthracnose on various chili varieties caused by *Colletotrichum scovillei* in Korea. *Mycobiology* 45:184–191. <https://doi.org/10.5941/MYCO.2017.45.3.184>
- Oo MM, Yoon H-Y, Jang HA, Oh S-K (2018) Identification and characterization of *Colletotrichum* species associated with bitter rot disease of apple in South Korea. *Plant Pathol J* 34:480–489. <https://doi.org/10.5423/PJ.FT.10.2018.0201>
- Oo MM, Kim M-R, Kim D-G, Kwak T-S, Oh S-K (2021) First report of *Colletotrichum siamense* causing Anthracnose of chili pepper fruit in Korea. *Plant Dis*. <https://doi.org/10.1094/pdis-10-20-2297-pdn> (in press)
- Padder BA, Sharma PN, Awale HE, Kelly JD (2017) *Colletotrichum lindemuthianum*, the causal agent of bean Anthracnose. *J Plant Pathol* 99:317–330. <https://doi.org/10.4454/jpp.v99i2.3867>
- Pal N, Testen AL (2021) First report of quinoa anthracnose caused by *Colletotrichum nigrum* and *C. truncatum* in the United States. *Plant Dis* 105:705. <https://doi.org/10.1094/PDIS-07-20-1568-PDN>
- Palmateer AJ, Tarnowski TLB, Lopez P (2012) First report of *Colletotrichum sansevieriae* causing Anthracnose of *Sansevieria trifasciata* in Florida. *Plant Dis* 96:293. <https://doi.org/10.1094/PDIS-06-11-0539>
- Pan H, Deng L, Feng DD, Zhong CH, Li L (2021) First report of Anthracnose caused by *Colletotrichum gloeosporioides* on *Akebia trifoliata* in China. *Plant Dis* 105:499. <https://doi.org/10.1094/PDIS-07-20-1525-PDN>
- Paniz-Mondolfi AE, Agemy S, Cañete-Gibas C, Gitman MR, Jacob CE, Necula I, Wang C-Y, Delgado Noguera LA, Sanders C, Wiederhold NP, Sordillo EM, Nowak MD (2021) First report of human infection caused by *Colletotrichum chlorophyti* occurring in a post-corneal transplant patient with endophthalmitis. *Med Mycol Case Rep* 32:73–76. <https://doi.org/10.1016/j.mmcr.2021.04.002>
- Pardo-De la Hoz CJ, Calderón C, Rincón AM, Cárdenas M, Danies G, López-Kleine L, Restrepo S, Jiménez P (2016) Species from the *Colletotrichum acutatum*, *Colletotrichum boninense* and *Colletotrichum gloeosporioides* species complexes associated with tree tomato and mango crops in Colombia. *Plant Pathol* 65:227–237. <https://doi.org/10.1111/ppa.12410>
- Park JH, Han KS, Kim JY, Shin HD (2013) First report of Anthracnose caused by *Colletotrichum sansevieriae* on *Sansevieria* in Korea. *Plant Dis* 97:1510. <https://doi.org/10.1094/PDIS-04-13-0402-PDN>
- Pavlović ŽM, Santander RD, Meredith CL, Aćimović SG (2019) First report of *Colletotrichum fioriniae* causing bitter rot on Asian pear (*Pyrus pyrifolia*) and common pear (*Pyrus communis*) in New York, U.S.A. *Plant Dis* 103:1032. <https://doi.org/10.1094/PDIS-09-18-1500-PDN>
- Peng L-J, Sun T, Yang Y-L, Cai L, Hyde KD, Bahkali AH, Liu Z-Y (2013) *Colletotrichum* species on grape in Guizhou and Yunnan provinces, China. *Mycoscience* 54:29–41. <https://doi.org/10.1016/j.myc.2012.07.006>
- Penzig IAJ (1882) *Funghi agrumicoli: contribuzione allo studio dei funghi parassiti degli agrumi*. P. Fracanzani
- Pérez-Mora JL, Cota-Rodríguez DA, Rodríguez-Palafox EE, García-León E, Beltrán-Peña H, Lima NB, Tovar-Pedraza JM (2020) First confirmed report of *Colletotrichum coccodes* causing black dot on potato in Mexico. *J Plant Dis Protect* 127:269–273. <https://doi.org/10.1007/s41348-019-00291-z>
- Perrone G, Magistà D, Ismail AM (2016) First report of *Colletotrichum kahawae* subsp. *ciggaro* on mandarin in Italy. *J Plant Pathol* 98:682. <https://doi.org/10.4454/JPP.V98I3.012>
- Phoulivong S, Cai L, Chen H, McKenzie EHC, Abdelsalam K, Chukeatirote E, Hyde KD (2010) *Colletotrichum gloeosporioides* is not a common pathogen on tropical fruits. *Fungal Divers* 44:33–43. <https://doi.org/10.1007/s13225-010-0046-0>
- Pires AS, Azinheira HG, Cabral A, Tavares S, Tavares D, Castro M, Várzea V, Silva MC, Abranches R, Loureiro J, Talhinhos P (2016) Cytogenomic characterization of *Colletotrichum kahawae*, the causal agent of coffee berry disease, reveals diversity in minichromosome profiles and genome size expansion. *Plant Pathol* 65:968–977. <https://doi.org/10.1111/ppa.12479>
- Poletto T, Muniz MFB, Blume E, Fantinel VS, Reiniger LRS, Brioso PST, Harakava R, Stefenon VM, Poletto I (2019) First report of *Colletotrichum nymphaeae* causing Anthracnose on *Carya illinoensis* in Brazil. *Plant Dis* 103:3277. <https://doi.org/10.1094/PDIS-04-19-0896-PDN>

- Prasad L, Javeria S, Kumar B, Sharma P (2017) First report of anthracnose of elephant foot yam caused by *Colletotrichum siamense* in India. *New Dis Rep* 36:21. <https://doi.org/10.5197/j.2044-0588.2017.036.021>
- Prasannath K, Galea VJ, Akinsanmi AO (2020) Characterisation of leaf spots caused by *Neopestalotiopsis clavispora* and *Colletotrichum siamense* in macadamia in Australia. *Eur J Plant Pathol* 156:1219–1225. <https://doi.org/10.1007/s10658-020-01962-6>
- Price MN, Dehal PS, Arkin AP (2010) FastTree 2—approximately maximum-likelihood trees for large alignments. *PLoS ONE* 5:e9490. <https://doi.org/10.1371/journal.pone.0009490>
- Pszczołkowska A, Okorski A, Paukszto Ł, Jastrzębski JP, Gorzkowska A, Chareńska A, Makowczenko KG (2017) First report of *Fagus sylvatica* leaf spot infection by *Colletotrichum fioriniae* in forest nurseries in Northeastern Poland. *Plant Dis* 101:1822. <https://doi.org/10.1094/PDIS-04-17-0471-PDN>
- Qin LP, Zhang Y, Su Q, Chen YL, Nong Q, Xie L, Yu GM, Huang SL (2019) First report of Anthracnose of *Mangifera indica* caused by *Colletotrichum scovillei* in China. *Plant Dis* 103:1043. <https://doi.org/10.1094/PDIS-11-18-1980-PDN>
- Qin X, Zhang Y, Lan D, Su X, Lin W, Yuan G (2021) First report of leaf spot caused by *Colletotrichum siamense* on *Michelia alba* in China. *Plant Dis*. <https://doi.org/10.1094/pdis-11-20-2399-pdn> ((in press))
- Qiu F, Li X, Xie CP, Li J, Zheng FQ (2021) Identification of *Colletotrichum brevisporum* causing fruit rot in yellow passion fruit (*Passiflora edulis* f. *flavicarpa*) in China. *Australas Plant Pathol* 50:229–232. <https://doi.org/10.1007/s13313-020-00766-w>
- Rakotoniriana EF, Scaufflaire J, Rabemanantsoa C, Urveg-Ratsimamanga S, Corbisier A-M, Quetin-Leclercq J, Declercq S, Munaut F (2013) *Colletotrichum gigasporum* sp. nov., a new species of *Colletotrichum* producing long straight conidia. *Mycol Prog* 12:403–412. <https://doi.org/10.1007/s11557-012-0847-5>
- Ramos AP, Talhinas P, Sreenivasaprasad S, Oliveira H (2016) Characterization of *Colletotrichum gloeosporioides* as the main causal agent of citrus anthracnose, and *C. karstii* as species preferentially associated with lemon twig dieback in Portugal. *Phytoparasitica* 44:549–561. <https://doi.org/10.1007/s12600-016-0537-y>
- Rashid TS, Sijam K, Kadir J, Saud HM, Awla HK, Hata EM (2015) First report of tomato anthracnose caused by *Colletotrichum boninense* in Malaysia. *J Plant Pathol* 97:216. <https://doi.org/10.4454/JPP.V97I1.021>
- Rashid H, Ahmed R, Chowdury S, Azad AK, Raihan T, Haque MMU (2020) First report of *Colletotrichum viniferum* causing leaf spot of *Hopea odorata* in Bangladesh. *New Dis Rep* 42:19. <https://doi.org/10.5197/j.2044-0588.2020.042.019>
- Rather RA, Srinivasan V, Anwar M (2018) Seasonal deviation effects foliar endophyte assemblage and diversity in *Asparagus racemosus* and *Hemidesmus indicus*. *BMC Ecol* 18:52. <https://doi.org/10.1186/s12898-018-0211-y>
- Réblová M, Gams W, Seifert KA (2011) Monilochaetes and allied genera of the Glomerellales, and a reconsideration of families in the Microascales. *Stud Mycol* 68:163–191. <https://doi.org/10.3114/sim.2011.68.07>
- Rennberger G, Gerard P, Keinath AP (2018) Occurrence of foliar pathogens of watermelon on commercial farms in South Carolina estimated with stratified cluster sampling. *Plant Dis* 102:2285–2295. <https://doi.org/10.1094/PDIS-03-18-0468-RE>
- Riera N, Ramirez-Villacis D, Barriga-Medina N, Alvarez-Santana J, Herrera K, Ruales C, Leon-Reyes A (2019) First report of banana Anthracnose caused by *Colletotrichum gloeosporioides* in Ecuador. *Plant Dis* 103:763. <https://doi.org/10.1094/PDIS-01-18-0069-PDN>
- Rios JA, Pinho DB, Moreira WR, Pereira OL, Rodrigues FA (2015) First report of *Colletotrichum karstii* causing Anthracnose on blueberry leaves in Brazil. *Plant Dis* 99:157. <https://doi.org/10.1094/PDIS-07-14-0717-PDN>
- Rivera Y, Stommel J, Dumm J, Ismaiel A, Wyenandt CA, Crouch JA (2016) First report of *Colletotrichum nigrum* causing Anthracnose disease on tomato fruit in New Jersey. *Plant Dis* 100:2162. <https://doi.org/10.1094/PDIS-02-16-0174-PDN>
- Rodríguez-Palafox EE, Vásquez-López A, Márquez-Licona G, Lima NB, Lagunes-Fortiz E, Tovar-Pedraza JM (2021) First report of *Colletotrichum siamense* causing Anthracnose of guava (*Psidium guajava*) in Mexico. *Plant Dis*. <https://doi.org/10.1094/PDIS-03-21-0530-PDN> ((in press))
- Rogério F, Gladieux P, Massola NS Jr, Ciampi-Guillard M (2019) Multiple introductions without admixture of *Colletotrichum truncatum* associated with soybean Anthracnose in Brazil. *Phytopathology* 109:681–689. <https://doi.org/10.1094/PHYTO-08-18-0321-R>
- Rogério F, Bouffeur TR, Ciampi-Guillard M, Sukno SA, Thon MR, Massola N, Baroncelli R (2020) Genome sequence resources of *Colletotrichum truncatum*, *C. plurivorum*, *C. musicola* and *C. sojae*: four species pathogenic to soybean (*Glycine max*). *Phytopathology* 110:1497–1499. <https://doi.org/10.1094/PHYTO-03-20-0102-A>
- Rojas EI, Rehner SA, Samuels GJ, Van Bael SA, Herre EA, Cannon P, Chen R, Pang J, Wang R, Zhang Y, Peng YQ, Sha T (2010) *Colletotrichum gloeosporioides* s.l. associated with *Theobroma cacao* and other plants in Panamá: multilocus phylogenies distinguish host-associated pathogens from asymptomatic endophytes. *Mycologia* 102:1318–1338. <https://doi.org/10.3852/09-244>
- Rojas P, Pardo-De la Hoz CJ, Calderón C, Vargas N, Cabrera LA, Restrepo S, Jiménez P (2018) First report of *Colletotrichum kahawae* subsp. *ciggaro* causing Anthracnose disease on tree tomato in Cundinamarca, Colombia. *Plant Dis* 102:2031. <https://doi.org/10.1094/PDIS-02-18-0353-PDN>
- Ronquist F, Teslenko M, van der Mark P, Ayres DL, Darling A, Höhna S, Larget B, Liu L, Suchard MA, Huelsenbeck JP (2012) MrBayes 3.2: efficient Bayesian phylogenetic inference and model choice across a large model space. *Syst Biol* 61:539–542. <https://doi.org/10.1093/sysbio/sys029>
- Rossman AY, Allen WC, Castlebury LA (2016) New combinations of plant-associated fungi resulting from the change to one name for fungi. *IMA Fungus* 7:1–7. <https://doi.org/10.5598/ima fungus.2016.07.01.01>
- Saini TJ, Gupta DG, Anandalakshmi R (2017a) First report of papaya anthracnose caused by *Colletotrichum salsolae* in India. *New Dis Rep* 35:27. <https://doi.org/10.5197/j.2044-0588.2017.035.027>
- Saini TJ, Gupta DG, Anandalakshmi R (2017b) Detection of tomato anthracnose caused by *Colletotrichum truncatum* in India. *Australas Plant Dis Notes* 12:48. <https://doi.org/10.1007/s13314-017-0271-4>
- Salunkhe VN, Anandhan S, Gawande SJ, Ikkar RB, Bhagat YS, Mahajan V (2018a) First report of *Colletotrichum truncatum* causing Anthracnose of mouse garlic (*Allium angulosum*) in India. *Plant Dis* 102:240. <https://doi.org/10.1094/PDIS-04-17-0566-PDN>
- Salunkhe VN, Anandhan S, Gawande SJ, Ikkar EB, Bhagat YS, Mahajan V, Singh M (2018b) First report of Anthracnose caused by *Colletotrichum spaethianum* on *Allium ledebourianum* in India. *Plant Dis* 102:2031. <https://doi.org/10.1094/PDIS-01-18-0104-PDN>
- Samac DA, Allen S, Witte D, Miller D, Peterson J (2014) First report of race 2 of *Colletotrichum trifolii* causing Anthracnose on alfalfa (*Medicago sativa*) in Wisconsin. *Plant Dis* 98:843. <https://doi.org/10.1094/PDIS-08-13-0808-PDN>
- Samarakoon MC, Peršoh D, Hyde KD, Bulgakov TS, Manawasinghe IS, Jayawardena RS, Promputtha I (2018) *Colletotrichum acidiae*

- sp. nov.* from northern Thailand and a new record of *C. dematium* on *Iris* sp. Mycosphere 9:583–597. <https://doi.org/10.5943/mycosphere/9/3/9>
- Sangpueak R, Phansak P, Buensanteai N (2018) Morphological and molecular identification of *Colletotrichum* species associated with cassava anthracnose in Thailand. J Phytopathol 166:129–142. <https://doi.org/10.1111/jph.12669>
- Santana KFA, Garcia CB, Matos KS, Hanada RE, Silva GF, Sousa NR (2016) First report of anthracnose caused by *Colletotrichum spaethianum* on *Allium fistulosum* in Brazil. Plant Dis 100:224. <https://doi.org/10.1094/PDIS-07-15-0737-PDN>
- Santos RF, Massola Júnior NS, Bremer Neto H, Jacomino AP, Spósito MB (2017) First report of *Colletotrichum theobromicola* causing Anthracnose leaf and twig spot in Cambuci (*Campomanesia phaea*) in Brazil. Plant Dis 101:506. <https://doi.org/10.1094/PDIS-08-16-1196-PDN>
- Sanz-Martín JM, Postigo V, Mateos A, Albrecht B, Munkvold GP, Thon MR, Sukno SA (2016) First report of *Colletotrichum graminicola* causing maize Anthracnose stalk rot in the Alentejo region, Portugal. Plant Dis 100:648. <https://doi.org/10.1094/PDIS-06-15-0636-PDN>
- Sato T, Moriwaki J, Uzuhashi S, Degawa Y, Ono T, Nishimura K (2012) Molecular phylogenetic analyses and morphological re-examination of strains belonging to three rare *Colletotrichum* species in Japan. Microbiol Cult Coll 28:121–134
- Sato T, Moriwaki J, Kaneko S (2015) Anthracnose fungi with curved conidia, *Colletotrichum* spp. belonging to Ribosomal Groups 9–13, and their host ranges in Japan. Jpn Agric Res Q 49:351–362. <https://doi.org/10.6090/jarq.49.351>
- Savian LG, Muniz MFB, Poletto T, Maculan LG, Rabuske JE, Blume E, Sarzi JS (2019) First report of *Colletotrichum nymphaeae* causing Anthracnose on *Juglans regia* fruits in Southern Brazil. Plant Dis 103:3287. <https://doi.org/10.1094/PDIS-06-19-1199-PDN>
- Schena L, Mosca S, Cacciola SO, Faedda R, Sanzani SM, Agosteo GE, Sergeeva V, di San M, Lio G (2014) Species of the *Colletotrichum gloeosporioides* and *C. boninense* complexes associated with olive Anthracnose. Plant Pathol 63:437–446. <https://doi.org/10.1111/ppa.12110>
- Schoeneberg A, Hu M-J (2020) First report of Anthracnose fruit rot caused by *Colletotrichum fioriniae* on red raspberry (*Rubus idaeus*) in the mid-atlantic region of the United States. Plant Dis 104:1855. <https://doi.org/10.1094/PDIS-10-19-2256-PDN>
- Serdani M, Rooney-Latham S, Wallis KM, Blomquist CL (2013) First report of *Colletotrichum phormii* causing Anthracnose on New Zealand flax in the United States. Plant Dis 97:1115. <https://doi.org/10.1094/PDIS-12-12-1155-PDN>
- Serrato-Díaz LM, Rivera-Vargas LI, Goenaga R, Navarro ED, French-Monar RD (2017) First report of *Colletotrichum fruticicola* and *C. queenslandicum* causing fruit rot of rambutan (*Nephelium lappaceum*). Plant Dis 101:1043. <https://doi.org/10.1094/PDIS-11-16-1557-PDN>
- Sezer A, Dolar FS, Ünal F (2017) First report of *Colletotrichum fioriniae* infection of hazelnut. Mycotaxon 132:495–502. <https://doi.org/10.5248/132.495>
- Sharma G, Kumar N, Weir BS, Hyde KD, Shenoy BD (2013) The *ApMat* marker can resolve *Colletotrichum* species: a case study with *Mangifera indica*. Fungal Divers 61:117–138. <https://doi.org/10.1007/s13225-013-0247-4>
- Sharma K, Goss E, van Bruggen AHC (2014) Isolation and identification of the fungus *Colletotrichum cordylinicola* causing Anthracnose disease on *Cordyline fruticosa* in Florida. HortScience 49:911–916. <https://doi.org/10.21273/HORTSCI.49.7.911>
- Sharma G, Pinnaka AK, Shenoy BD (2015) Resolving the *Colletotrichum siamense* species complex using *ApMat* marker. Fungal Divers 71:247. <https://doi.org/10.1007/s13225-014-0312-7>
- Sharma G, Maymon M, Freeman S (2016) First report of *Colletotrichum theobromicola* causing leaf spot of *Cyclamen persicum* in Israel. Plant Dis 100:1790. <https://doi.org/10.1094/PDIS-02-16-0208-PDN>
- Sharma G, Maymon M, Freeman S (2017) Epidemiology, pathology and identification of *Colletotrichum* including a novel species associated with avocado (*Persea americana*) anthracnose in Israel. Sci Rep 7:15839. <https://doi.org/10.1038/s41598-017-15946-w>
- Shen J, Dong LK, Wang ZH, Yu JY, Zou FL (2017) First report of Anthracnose caused by *Colletotrichum gloeosporioides* on *Ligustrum japonicum* in China. Plant Dis 101:1329. <https://doi.org/10.1094/PDIS-12-16-1826-PDN>
- Shi Y-X, Zhang X-H, Zhao Q, Li B-J (2019) First report of *Colletotrichum gloeosporioides* causing Anthracnose on Okra in China. Plant Dis 103:1023. <https://doi.org/10.1094/PDIS-05-18-0878-PDN>
- Shi X, Wang S, Duan X, Gao X, Zhu X, Laborda P (2021) First report of *Colletotrichum brevisporum* causing soybean Anthracnose in China. Plant Dis 105:707. <https://doi.org/10.1094/PDIS-09-20-1910-PDN>
- Shivas RG, Tan YP (2009) A taxonomic re-assessment of *Colletotrichum acutatum*, introducing *C. fioriniae* comb. et stat. nov. and *C. simmondsii* sp. nov. Fungal Divers 39:111–122
- Shivas RG, Bathgate J, Podger FD (1998) *Colletotrichum xanthorrhoeae* sp. nov. on *Xanthorrhoea* in Western Australia. Mycol Res 102:280–282. <https://doi.org/10.1017/S0953756297004760>
- Shivas RG, Tan YP, Edwards J, Dinh Q, Maxwell A, Andjic V, Liberato JR, Anderson C, Beasley DR, Bransgrove K, Coates LM, Cowan K, Daniel R, Dean JR, Lomavatu MF, Mercado-Escueta D, Mitchell RW, Thangavel R, Tran-Nguyen LTT, Weir BS (2016) *Colletotrichum* species in Australia. Australas Plant Pathol 45:447–464. <https://doi.org/10.1007/s13313-016-0443-2>
- Silva DN, Talhinhos P, Cai L, Manuel L, Guichuru EK, Loureiro A, Várzea V, Paulo OS, Batista D (2012a) Host-jump drives rapid and recent ecological speciation of the emergent fungal pathogen *Colletotrichum kahawae*. Molec Ecol 21:2655–2670. <https://doi.org/10.1111/j.1365-294X.2012.05557.x>
- Silva DN, Talhinhos P, Várzea V, Cai L, Paulo OS, Batista D (2012b) Application of the *Apn2/MAT* locus to improve the systematics of the *Colletotrichum gloeosporioides* complex: an example from coffee (*Coffea* spp.) hosts. Mycologia 104:396–409. <https://doi.org/10.3852/11-145>
- Silva AO, Savi DC, Gomes FB, Gos FMWR, Silva GJ Jr, Glienke C (2017a) Identification of *Colletotrichum* species associated with postbloom fruit drop in Brazil through GAPDH sequencing analysis and multiplex PCR. Eur J Plant Pathol 147:731–748. <https://doi.org/10.1007/s10658-016-1038-z>
- Silva JRA, Chaves TP, Silva ARG, Barbosa LF, Costa JFO, Ramos-Sobrinho R, Teixeira RRO, Silva SJC, Lima GSA, Assunção IP (2017b) Molecular and morpho-cultural characterization of *Colletotrichum* spp. associated with anthracnose on *Capsicum* spp. in northeastern Brazil. Trop Plant Pathol 42:315–319. <https://doi.org/10.1007/s40858-017-0151-7>
- Silva M, Cruz ES, Veloso TGR, Miranda L, Pereira OL, Bocayuva MF, Kasuya MCM (2018) *Colletotrichum serranegrense* sp. nov., a new endophytic species from the roots of the endangered Brazilian epiphytic orchid *Cattleya jongheana*. Phytotaxa 351:163–170
- Silva JL, Silva WF, Lopes LEM, Silva MJS, Silva-Cabral JRA, Costa JFO, Lima GSA, Assunção IP (2021b) First report of *Colletotrichum tropicale* causing anthracnose on *Passiflora edulis* in Brazil. Plant Dis. <https://doi.org/10.1094/pdis-07-20-1440-pdn> ((in press))
- Silva-Cabral JRA, Batista LRL, Costa JFO, Ferro MMM, Silva SJC, Lima GSA, Assunção IP (2019) First report of *Colletotrichum*

- tropicale* causing Anthracnose on pomegranate in Brazil. Plant Dis 103:583. <https://doi.org/10.1094/PDIS-05-18-0767-PDN>
- Simmonds JH (1965) A study of the species of *Colletotrichum* causing ripe fruit rots in Queensland. Qld J Agric Anim Sci 22:437–459
- Singh R, Graney L, Williamson M (2015) First report of boxwood dieback caused by *Colletotrichum theobromicola* in the United States. Plant Dis 99:1274. <https://doi.org/10.1094/PDIS-09-14-0948-PDN>
- Soares WRO, Quitania ACR, Miller RNG, Café-Filho AC, Reis A, Pinho DB (2017) First worldwide report of *Colletotrichum pseudoacutatum* causing Anthracnose on *Syzygium jambos*. Plant Dis 101:1322. <https://doi.org/10.1094/PDIS-02-17-0261-PDN>
- Soares VF, Velho AC, Carachenski A, Astolfi P, Stadnik MJ (2021) First report of *Colletotrichum karstii* causing Anthracnose on strawberry in Brazil. Plant Dis. <https://doi.org/10.1094/PDIS-03-21-0518-PDN> (in press)
- Song LS, Jiang N, Chen QP, Feng SX, Zhang ZJ (2021) First report of leaf spot caused by *Colletotrichum siamense* on *Sophora tonkinensis*. Australas Plant Dis Notes 16:11. <https://doi.org/10.1007/s13314-021-00420-4>
- Sreenivasaprasad S, Talhinhos P (2005) Genotypic and phenotypic diversity in *Colletotrichum acutatum*, a cosmopolitan pathogen causing anthracnose on a wide range of hosts. Mol Plant Pathol 6:361–378. <https://doi.org/10.1111/j.1364-3703.2005.00291.x>
- Sukno SA, Sanz-Martín JM, González-Fuente M, Hiltbrunner J, Thon MR (2014) First report of Anthracnose stalk rot of maize caused by *Colletotrichum graminicola* in Switzerland. Plant Dis 98:694. <https://doi.org/10.1094/PDIS-09-13-0912-PDN>
- Sultana R, Lee K-J, Chae J-C, Lee S-J (2018) First report of *Colletotrichum acutatum* causing Anthracnose on *Rhododendron yedoense* var. *poukhanense* in South Korea. Plant Dis 102:2371. <https://doi.org/10.1094/PDIS-01-18-0178-PDN>
- Sun HY, Liang Y (2018) First report of Anthracnose on sunflower caused by *Colletotrichum destructivum* in China. Plant Dis 102:245. <https://doi.org/10.1094/PDIS-06-17-0910-PDN>
- Sun WM, Wen XL, Qi HX, Feng LN, Cao J, Han ZL, Yang WJ, Zhang MY, Han BJ, Meng TY (2019a) First report of Anthracnose of *Atractylodes chinensis* caused by *Colletotrichum chlorophyti* in China. Plant Dis 103:764. <https://doi.org/10.1094/PDIS-05-18-0838-PDN>
- Sun YC, Damm U, Huang CJ (2019b) *Colletotrichum plurivorum*, the causal agent of Anthracnose fruit rot of papaya in Taiwan. Plant Dis 103:1040. <https://doi.org/10.1094/PDIS-08-18-1423-PDN>
- Sun H, Sun L, Hong Y, Liang Y (2020a) First report of anthracnose on *Hosta ventricosa* caused by *Colletotrichum spaethianum* in China. Crop Protect 131:105104. <https://doi.org/10.1016/j.cropro.2020.105104>
- Sun X, Cai X, Pang Q, Zhou M, Zhang W, Chen Y, Bian Q (2020b) First report of *Colletotrichum truncatum* causing Anthracnose on *Piper betle* in China. Plant Dis 104:3074. <https://doi.org/10.1094/PDIS-10-19-2206-PDN>
- Sutton BC (1992) The genus *Glomerella* and its anamorph *Colletotrichum*. In: Bailey JA, Jeger MJ (eds) *Colletotrichum: biology, pathology and control*. BSPP/CAB International, Wallingford, UK, pp 1–26
- Świdarska-Burek U (2021) The third report of *Colletotrichum japonicum* worldwide. Acta Mycol 56:565. <https://doi.org/10.5586/am.565>
- Taba S, Fukuchi K, Tamashiro Y, Tomitaka Y, Sekine K-T, Ajitomi A, Takushi T (2020) First report of anthracnose of jaboticaba caused by *Colletotrichum tropicale* in Japan. J Gen Plant Pathol 86:65–69. <https://doi.org/10.1007/s10327-019-00881-7>
- Talhinhos P, Sreenivasaprasad S, Neves-Martins J, Oliveira H (2005) Molecular and phenotypic analyses reveal the association of diverse *Colletotrichum acutatum* groups and a low level of *C. gloeosporioides* with olive anthracnose. Appl Environ Microbiol 71:2987–2998. <https://doi.org/10.1128/AEM.71.6.2987-2998.2005>
- Talhinhos P, Barancelli R, Le Floch G (2016) Anthracnose of lupins caused by *Colletotrichum lupini*: a recent disease and a successful worldwide pathogen. J Plant Pathol 98:5–14. <https://doi.org/10.4454/JPP.V98I1.040>
- Talhinhos P, Loureiro A, Oliveira H (2018) Olive anthracnose: a yield and oil quality degrading-disease caused by several species of *Colletotrichum* that differ in virulence, host preference and geographic distribution. Molec Plant Pathol 19:1797–1807. <https://doi.org/10.1111/mpp.12676>
- Talhinhos P, Carvalho R, Figueira R, Ramos AP (2019) An annotated checklist of rust fungi (Pucciniales) occurring in Portugal. Sydowia 71:65–84. <https://doi.org/10.12905/0380.sydowia71-2019-0065>
- Tan LL, Guo LZ, Song LM, Li DL, Liang WX, Liu L (2017) First report of *Colletotrichum gloeosporioides* causing leaf spot on *Pteridium aquilinum* in China. Plant Dis 101:1054. <https://doi.org/10.1094/PDIS-12-16-1848-PDN>
- Tang S-F, Tan L (2020) First report of *Colletotrichum gloeosporioides* causing leaf spots on *Rubia cordifolia* L. in Qingdao, China. Plant Dis 104:2733. <https://doi.org/10.1094/PDIS-02-20-0292-PDN>
- Tang Z, Sun X, Ye M, Cui R (2018) First report of leaf spot on *Osmanthus fragrans* caused by *Colletotrichum gloeosporioides* in Jiangxi Province of China. Plant Dis 102:1035. <https://doi.org/10.1094/PDIS-08-17-1262-PDN>
- Tao G, Liu Z-Y, Liu F, Gao Y-H, Cai L (2013) Endophytic ispecies from *Bletilla ochracea* (Orchidaceae), with descriptions of seven new species. Fungal Divers 61:139–164. <https://doi.org/10.1007/s13225-013-0254-5>
- Tapia-Tussell R, Cortés-Velázquez A, Valencia-Yah T, Navarro C, Espinosa E, Moreno B, Perez-Brito D (2016) First report of *Colletotrichum magnum* causing Anthracnose in papaya in Mexico. Plant Dis 100:2323. <https://doi.org/10.1094/PDIS-03-16-0324-PDN>
- Tariq A, Naz F, Rauf CA, Irshad G, Abbasi NA, Khokhar NM (2017) First report of Anthracnose caused by *Colletotrichum truncatum* on bell pepper (*Capsicum annuum*) in Pakistan. Plant Dis 101:631. <https://doi.org/10.1094/PDIS-07-16-0996-PDN>
- Tibpromma S, Hyde KD, Jeewon R, Maharachchikumbura SSN, Liu J-K, Bhat DJ, Jones EBG, McKenzie EHC, Camporesi E, Bulgakov TS, Doilom M, Santiago ALCMA, Das K, Manimohan P, Gibertoni TB, Lim YW, Ekanayaka AH, Thongbai B, Lee HB, Yang J-B, Kirk PM, Singsuphanthong P, Singh SK, Boonmee S, Dong W, Raj KNA, Latha KPD, Phookamsak R, Phukhamsakda C, Konta S, Jayasiri SC, Norphanphoun C, Tennakoon DS, Li J, Dayarathne MC, Perera RH, Xiao Y, Wanasinghe DN, Senanayake IC, Goonasekara ID, Silva NI, Mapook A, Jayawardena RS, Dissanayake AJ, Manawasinghe IS, Chethana KWT, Luo Z-L, Hapuarachchi KK, Baghela A, Soares AM, Vizzini A, Meiras-Ottoni A, Mešić A, Dutta AK, Souza CAF, Richter C, Lin C-G, Chakrabarty D, Daranagama DA, Lima DX, Chakraborty D, Ercole E, Wu F, Simonini G, Vasquez G, Silva GA, Plautz HL Jr, Ariyawansa HA, Lee H, Kušan I, Song J, Sun J, Karmakar J, Hu K, Semwal KC, Thambugala KM, Voigt K, Acharya K, Rajeshkumar KC, Ryvarden L, Jadan M, Hosen MI, Mikšić M, Samarakoon MC, Wijayawardene NN, Kim NK, Matočec N, Singh PN, Tian Q, Bhatt RP, Oliveira RJV, Tulloss RE, Aamir S, Kaewchai S, Marathe SD, Khan S, Hongsanan S, Adhikari S, Mehmood T, Bandyopadhyay TK, Svetasheva TY, Nguyen TTT, Antonín V, Li W-J, Wang Y, Indoliya Y, Tkáčec Z, Elgorban AM, Bahkali AH, Tang AMC, Su H-Y, Zhang H, Promputtha I, Luangsa-ard J, Xu J, Yan J, Ji-Chuan K, Stahler M, Mortimer PE, Chomnunti P, Zhao Q, Phillips AJL, Nontachaiyapoom S, Wen T-C, Karunarathna SC (2017) Fungal diversity notes 491–602:

- taxonomic and phylogenetic contributions to fungal taxa. *Fungal Divers* 83:1–261. <https://doi.org/10.1007/s13225-017-0378-0>
- Tibpromma S, Hyde KD, Bhat JD, Mortimer PE, Xu J, Promputtha I, Doilom M, Yang J-B, Tang AMC, Karunarathna SC (2018) Identification of endophytic fungi from leaves of Pandanaceae based on their morphotypes and DNA sequence data from southern Thailand. *Mycologia* 33:25–67. <https://doi.org/10.3897/mycol.33.23670>
- Tomioka K, Nishikawa J, Moriwaki J, Sato T (2011) Anthracnose of snapdragon caused by *Colletotrichum destructivum*. *J Gen Plant Pathol* 77:60–63. <https://doi.org/10.1007/s10327-010-0278-6>
- Toporek SM, Keinath AP (2021) First report of *Colletotrichum scovillei* causing Anthracnose fruit rot on pepper in South Carolina, United States. *Plant Dis* 105:1222. <https://doi.org/10.1094/pdis-08-20-1656-pdn>
- Tóth A, Petrőczy M, Palkovics L (2017) First report of *Colletotrichum acutatum* sensu lato through the occurrence of *C. godetiae* on cornelian cherry (*Cornus mas*) in Europe. *Plant Dis* 101:841. <https://doi.org/10.1094/PDIS-11-16-1685-PDN>
- Tovar-Pedraza JM, Mora-Aguilera JA, Nava-Díaz C, Lima NB, Michereff SJ, Sandoval-Islas JS, Câmara MPS, Téliz-Ortiz D, Leyva-Mir SG (2020) Distribution and pathogenicity of *Colletotrichum* species associated with mango Anthracnose in Mexico. *Plant Dis* 104:137–146. <https://doi.org/10.1094/PDIS-01-19-0178-RE>
- Trigiano RN, Boggess SL, Bernard EC, Windham AS (2018) First report of a leaf Anthracnose on *Rohdea japonica* (Japanese sacred lily) caused by *Colletotrichum liriopes* (*Glomerella* species) in the United States. *Plant Dis* 102:2380. <https://doi.org/10.1094/PDIS-03-18-0388-PDN>
- Tsedaley B, Adugna G, Lemessa F (2016) Distribution and importance of sorghum Anthracnose (*Colletotrichum sublineolum*) in Southwestern and Western Ethiopia. *Plant Pathol J* 15:75–85. <https://doi.org/10.3923/ppj.2016.75.85>
- Udayanga D, Manamgoda DS, Liu X, Chukeatirote E, Hyde KD (2013) What are the common anthracnose pathogens of tropical fruits? *Fungal Divers* 61:165–179. <https://doi.org/10.1007/s13225-013-0257-2>
- Uematsu S, Kageyama K, Moriwaki J, Sato T (2012) *Colletotrichum carthami comb. nov.*, an anthracnose pathogen of safflower, garland chrysanthemum and pot marigold, revived by molecular phylogeny with authentic herbarium specimens. *J Gen Plant Pathol* 78:316–333. <https://doi.org/10.1007/s10327-012-0397-3>
- Uysal A, Kurt Ş (2019) First report of *Colletotrichum karstii* causing anthracnose on citrus in the Mediterranean region of Turkey. *J Plant Pathol* 101:753. <https://doi.org/10.1007/s42161-018-00215-0>
- Valenzuela-Lopez N, Cano-Lira JF, Stchigel AM, Guarro J (2018) DNA sequencing to clarify the taxonomical conundrum of the clinical coelomycetes. *Mycoses* 61:708–717. <https://doi.org/10.1111/myc.12785>
- Varjas V, Kovács C, Lakatos T, Tóth T, Bujdosó G (2019) First report of walnut Anthracnose caused by *Colletotrichum fiorinae* on English (Persian) walnut fruits in Hungary. *Plant Dis* 103:3964. <https://doi.org/10.1094/PDIS-02-19-0286-PDN>
- Varjas V, Lakatos T, Tóth T, Kovács C (2021) First report of *Colletotrichum godetiae* causing Anthracnose and twig blight on persian walnut in Hungary. *Plant Dis* 105:702. <https://doi.org/10.1094/PDIS-03-20-0607-PDN>
- Vásquez-López A, Palacios-Torres RE, Camacho-Tapia M, Granados-Echegoyen C, Lima NB, Vera-Reyes I, Tovar-Pedraza JM, Leyva-Mir SG (2019) *Colletotrichum brevisporum* and *C. musicola* causing leaf Anthracnose of Taro (*Colocasia esculenta*) in Mexico. *Plant Dis* 103:2963. <https://doi.org/10.1094/PDIS-05-19-0967-PDN>
- Velázquez-del Valle MG, Campos-Martínez A, Flores-Moctezuma HE, Suárez-Rodríguez R, Ramírez-Trujillo JA, Hernández-Lauzardo NA (2016) First report of avocado Anthracnose caused by *Colletotrichum karstii* in Mexico. *Plant Dis* 100:534. <https://doi.org/10.1094/PDIS-03-15-0249-PDN>
- Velho AC, Stadnik MJ, Casanova L, Mondino P, Alaniz S (2014a) First report of *Colletotrichum karstii* causing glomerella leaf spot on apple in Santa Catarina State, Brazil. *Plant Dis* 98:157. <https://doi.org/10.1094/PDIS-05-13-0498-PDN>
- Velho AC, Stadnik MJ, Casanova L, Mondino P, Alaniz S (2014b) First report of *Colletotrichum nymphaeae* causing apple bitter rot in Southern Brazil. *Plant Dis* 98:567. <https://doi.org/10.1094/PDIS-06-13-0671-PDN>
- Velho AC, Alaniz S, Casanova L, Mondino P, Stadnik MJ (2015) New insights into the characterization of *Colletotrichum* species associated with apple diseases in southern Brazil and Uruguay. *Fungal Biol* 119:229–244. <https://doi.org/10.1016/j.funbio.2014.12.009>
- Velho AC, Stadnik MJ, Wallhead M (2019) Unraveling *Colletotrichum* species associated with Glomerella leaf spot of apple. *Trop Plant Pathol* 44:197–204. <https://doi.org/10.1007/s40858-018-0261-x>
- Veloso JS, Câmara MPS, Lima WG, Michereff SJ, Doyle VP (2018) Why species delimitation matters for fungal ecology: *Colletotrichum* diversity on wild and cultivated cashew in Brazil. *Fungal Biol* 122:677–691. <https://doi.org/10.1016/j.funbio.2018.03.005>
- Vieira WAS, Nascimento RJ, Michereff SJ, Hyde KD, Câmara MPS (2013) First report of papaya fruit Anthracnose caused by *Colletotrichum brevisporum* in Brazil. *Plant Dis* 97:1659. <https://doi.org/10.1094/PDIS-05-13-0520-PDN>
- Vieira WAS, Michereff SJ, Oliveira AC, Santos A, Câmara MPS (2014) First report of Anthracnose caused by *Colletotrichum spaethianum* on *Hemerocallis flava* in Brazil. *Plant Dis* 98:997. <https://doi.org/10.1094/PDIS-10-13-1026-PDN>
- Vieira WAS, Lima WG, Nascimento ES, Michereff SJ, Câmara MPS, Doyle VP (2017) The impact of phenotypic and molecular data on the inference of *Colletotrichum* diversity associated with *Musa*. *Mycologia* 109:912–934. <https://doi.org/10.1080/00275514.2017.1418577>
- Vieira WAS, Nunes AS, Veloso JS, Machado AR, Balbino VQ, Silva AC, Gomes AAM, Doyle VP, Câmara MPS (2020) *Colletotrichum truncatum* causing anthracnose on papaya fruit (*Carica papaya*) in Brazil. *Australas Plant Dis Notes* 15:2. <https://doi.org/10.1007/s13314-019-0371-4>
- Villafana RT, Ramdass AD, Rampersad SN (2019) *Colletotrichum brevisporum* is associated with anthracnose of red bell pepper fruit in Trinidad. *New Dis Rep* 39:11. <https://doi.org/10.5197/j.2044-0588.2019.039.011>
- von Arx JA (1957) Die Arten der Gattung *Colletotrichum* Cda. *Phytopathol Z* 29:414–468
- Waller JM, Bridge PD, Black R, Hakiza G (1993) Characterization of the coffee berry disease pathogen *Colletotrichum kahawae* sp. nov. *Mycol Res* 97:989–994. [https://doi.org/10.1016/S0953-7562\(09\)80867-8](https://doi.org/10.1016/S0953-7562(09)80867-8)
- Wan Y, Zou L, Zeng L, Tong H, Chen Y (2021) A new *Colletotrichum* species associated with brown blight disease on *Camellia sinensis*. *Plant Dis*. <https://doi.org/10.1094/PDIS-09-20-1912-RE> ((in press))
- Wang M, Wang H (2021) First report of leaf anthracnose caused by *Colletotrichum liriopes* on *Ophiopogon japonicus* in China. *Crop Protect* 140:105418. <https://doi.org/10.1016/j.cropro.2020.105418>
- Wang Y-C, Hao X-Y, Wang L, Xiao B, Wang X-C, Yang Y-J (2016) Diverse *Colletotrichum* species cause anthracnose of tea plants (*Camellia sinensis* (L.) O. Kuntze) in China. *Sci Rep* 6:35287. <https://doi.org/10.1038/srep35287>
- Wang Q-H, Fan K, Li D-W, Niu S-G, Hou L-Q, Wu X-Q (2017) Walnut anthracnose caused by *Colletotrichum siamense* in China.

- Australas Plant Pathol 46:585–595. <https://doi.org/10.1007/s13313-017-0525-9>
- Wang Y, Qin HY, Liu YX, Fan ST, Sun D, Yang YM, Li CY, Ai J (2019a) First report of Anthracnose caused by *Colletotrichum aenigma* on *Actinidia arguta* in China. Plant Dis 103:372. <https://doi.org/10.1094/PDIS-07-18-1137-PDN>
- Wang Q, Liu X, Ma H, Shen X, Hou C (2019b) *Colletotrichum yulongense* sp. nov. and *C. rhombiforme* isolated as endophytes from *Vaccinium dunalianum* var. *urophyllum* in China. PhytoTaxa 394:285–298
- Wang Q, Duan TY, Nan ZB (2019c) First report of Anthracnose caused by *Colletotrichum spinaciae* on *Vicia sativa* in China. Plant Dis 103:2138. <https://doi.org/10.1094/PDIS-01-19-0218-PDN>
- Wang Y, Chen J-Y, Xu X, Cheng J, Zheng L, Huang J, Li D-W (2020a) Identification and characterization of *Colletotrichum* Species associated with Anthracnose disease of *Camellia oleifera* in China. Plant Dis 104:474–482. <https://doi.org/10.1094/PDIS-11-18-1955-RE>
- Wang Q-H, Fan K, Li D-W, Han C-M, Qu Y-Y, Qi Y-K, Wu X-Q (2020b) Identification, virulence and fungicide sensitivity of *Colletotrichum gloeosporioides* s.s. responsible for walnut Anthracnose disease in China. Plant Dis 104:1358–1368. <https://doi.org/10.1094/PDIS-12-19-2569-RE>
- Wang W, Zhang J, Li J (2020c) First report of *Colletotrichum siamense* causing stem tip dieback of Sacha Inchi (*Plukenetia volubilis*) in China. Plant Dis 104:2726. <https://doi.org/10.1094/PDIS-03-20-0458-PDN>
- Wang Q-H, Li X-Y, Xu T-T, Zhang M-A, Yang Y-H, Feng P-B, Fan S-S, Liu Z-Y (2021a) Identification and characterization of *Colletotrichum gloeosporioides* sensu stricto, the agent of anthracnose disease of *Sorbaria sorbifolia* in China. J Gen Plant Pathol 87:71–76. <https://doi.org/10.1007/s10327-020-00973-9>
- Wang Q-T, Liu F, Hou C-L, Cai L (2021b) Species of *Colletotrichum* on bamboos from China. Mycologia 113:420–458. <https://doi.org/10.1080/00275514.2020.1837567>
- Wang W, de Silva DD, Moslemi A, Edwards J, Ades PK, Crous PW, Taylor PWJ (2021c) *Colletotrichum* species causing Anthracnose of citrus in Australia. J Fungi 7:47. <https://doi.org/10.3390/jof7010047>
- Wang QH, Zhang Y, Zhang YT, Li D, Lin XL, Lyu J (2021d) First report of *Colletotrichum siamense* causing anthracnose on *Cornus hongkongensis* (Hemsl.) in China. Plant Dis. <https://doi.org/10.1094/pdis-11-20-2525-pdn> ((in press))
- Wang X, Liu X, Wang R, Fa L, Chen L, Xin X, Zhang Y, Tian H, Xia M, Hou X (2021e) First report of *Colletotrichum aenigma* causing walnut Anthracnose in China. Plant Dis 105:225. <https://doi.org/10.1094/PDIS-07-20-1430-PDN>
- Watanabe K, Ikeda H, Sakashita T, Sato T (2016) Anthracnose of genus *Mandevilla* caused by *Colletotrichum truncatum* and *C. siamense* in Japan. J Gen Plant Pathol 82:33–37. <https://doi.org/10.1007/s10327-015-0635-6>
- Weir BS, Johnston PR (2010) Characterisation and neotypification of *Gloeosporium kaki* Hori as *Colletotrichum horii* nom. nov. Mycotaxon 111:209–219. <https://doi.org/10.5248/111.209>
- Weir BS, Johnston PR, Damm U (2012) The *Colletotrichum gloeosporioides* species complex. Stud Mycol 73:115–180. <https://doi.org/10.3114/sim0011>
- Wenneker M, Pham KTK, Lemmers MEC, de Boer FA, van der Lans AM, van Leeuwen PJ, Hollinger TC (2016) First report of *Colletotrichum godetiae* causing bitter rot on ‘Golden Delicious’ apples in the Netherlands. Plant Dis 100:218. <https://doi.org/10.1094/PDIS-05-15-0589-PDN>
- Werbel WA, Baroncelli R, Shoham S, Zhang SX (2019) Angioinvasive, cutaneous infection due to *Colletotrichum siamense* in a stem cell transplant recipient: report and review of prior cases. Transpl Infect Dis 21:e13153. <https://doi.org/10.1111/tid.13153>
- Wikee S, Cai L, Pairin N, McKenzie EHC, Su Y-Y, Chukeatirote E, Thi HN, Bahkali AH, Moslem MA, Abdelsalam K, Hyde KD (2011) *Colletotrichum* species from Jasmine (*Jasminum sambac*). Fungal Divers 46:171–182. <https://doi.org/10.1007/s13225-010-0049-x>
- Wilson AM, Lelwala RV, Taylor PWJ, Wingfield MJ, Wingfield BD (2021) Unique patterns of mating pheromone presence and absence could result in the ambiguous sexual behaviors of *Colletotrichum* species. Genes Genomes Genet 11(9):jkab187. <https://doi.org/10.1093/g3journal/jkab187>
- Win PM, Matsumura E, Fukuda K (2018) Diversity of tea endophytic fungi: cultivar- and tissue preferences. Appl Ecol Environ Res 16:677–695. https://doi.org/10.15666/aeer/1601_677695
- Woo J, Kim J-E, Kim M, Cha B (2021) First report of Mochi tree (*Ilex integra*) Anthracnose caused by *Colletotrichum fioriniae* in Korea. Plant Dis 105:1218. <https://doi.org/10.1094/pdis-07-20-1559-pdn>
- Wu M (2020) First report of *Colletotrichum siamense* causing Anthracnose on *Euonymus japonicus* in China. Plant Dis 104:587. <https://doi.org/10.1094/PDIS-04-19-0824-PDN>
- Wu WX, Huang XQ, Liu Y, Zhang L (2017) First report of apple bitter rot caused by *Colletotrichum rhombiforme* in China. Plant Dis 101:1033. <https://doi.org/10.1094/PDIS-01-17-0007-PDN>
- Wu WX, Liu Y, Huang XQ, Zhang L (2018) First report of Anthracnose caused by *Colletotrichum nymphaeae* on loquat fruit in China. Plant Dis 102:243. <https://doi.org/10.1094/PDIS-06-17-0828-PDN>
- Wu J, Wang H, Fang L, Xie Y, Wang L (2021) First report of *Colletotrichum fructicola* and *Colletotrichum nymphaeae* causing leaf spot on *Rubus corchorifolius* in Zhejiang province, China. Plant Dis. <https://doi.org/10.1094/PDIS-01-21-0198-PDN> ((in press))
- Wynns AA, Jensen AB, Eilenberg J, Delalibera Júnior I (2019) *Colletotrichum nymphaeae* var. *entomophilum* var. nov. a natural enemy of the citrus scale insect, *Praelongorthezia praelonga* (Hemiptera: Ortheziidae). Sci Agric 77:e20180269. <https://doi.org/10.1590/1678-992x-2018-0269>
- Xavier KV, Mizubuti ESG, Queiroz MV, Chopra S, Vaillancourt L (2018) Genotypic and pathogenic diversity of *Colletotrichum sublineola* isolates from sorghum (*Sorghum bicolor*) and Johnsongrass (*S. halepense*) in the Southeastern United States. Plant Dis 102:2341–2351. <https://doi.org/10.1094/PDIS-04-18-0562-RE>
- Xavier KV, Achala NKC, Peres NA, Deng Z, Castle W, Lovett W, Vallad GE (2019) Characterization of *Colletotrichum* species causing Anthracnose of pomegranate in the Southeastern United States. Plant Dis 103:2771–2780. <https://doi.org/10.1094/PDIS-03-19-0598-RE>
- Xu S, Li YZ (2015) First report of common vetch Anthracnose caused by *Colletotrichum lentis* in China. Plant Dis 99:1859. <https://doi.org/10.1094/PDIS-03-15-0272-PDN>
- Xu SJ, Aktaruzzaman M, Kim BS, Kim JY, Shin HD (2018a) First report of Anthracnose caused by *Colletotrichum fioriniae* on eggplant fruits in Korea. Plant Dis 102:2642. <https://doi.org/10.1094/PDIS-04-18-0711-PDN>
- Xu H, Zhou R, Fu J, Yuan Y, Ge X, Damm U (2018b) *Colletotrichum atractylodica* sp. nov.: the anthracnose pathogen of *Atractylodes chinensis* in China. Mycol Prog 17:393–402. <https://doi.org/10.1007/s11557-017-1359-0>
- Xu XL, Yang CL, Liu YG (2019) First report of Anthracnose caused by *Colletotrichum karstii* on *Taxus wallichiana* var. *mairei* in Sichuan, China. Plant Dis 103:2127. <https://doi.org/10.1094/PDIS-01-19-0033-PDN>
- Xu X, Xiao Q, Yang C, Liu Y (2021) First report of Anthracnose caused by *Colletotrichum karstii* on *Fatsia japonica* in Sichuan, China. Plant Dis 105:206. <https://doi.org/10.1094/PDIS-05-20-0990-PDN>

- Xue LH, Liu Y, Li CJ, Zhang L, Huang XQ (2017) First report of *Colletotrichum fioriniae* causing Anthracnose on *Ficus virens* in China. *Plant Dis* 101:1044. <https://doi.org/10.1094/PDIS-11-16-1592-PDN>
- Xue LH, Liu Y, Zhang L, Yang XX, Huang XQ, Wu WX (2018a) First report of *Colletotrichum gloeosporioides* causing Anthracnose on *Robinia pseudoacacia* in China. *Plant Dis* 102:2371. <https://doi.org/10.1094/PDIS-09-17-1448-PDN>
- Xue LH, Li CJ, Duan TY, Nan ZB (2018b) First report of Anthracnose caused by *Colletotrichum destructivum* on *Trifolium repens* in China. *Plant Dis* 102:249. <https://doi.org/10.1094/PDIS-07-17-1040-PDN>
- Xue L, Zhang L, Yang XX, Huang X, Wu W, Zhou X, White JF, Liu Y, Li C (2019) Characterization, phylogenetic analyses, and pathogenicity of *Colletotrichum* species on *Morus alba* in Sichuan Province, China. *Plant Dis* 103:2624–2633. <https://doi.org/10.1094/PDIS-06-18-0938-RE>
- Yamagishi N, Fujinaga M, Ishiyama Y, Ogiso H, Sato T, Tosa Y (2015) Life cycle and control of *Colletotrichum nymphaeae*, the causal agent of celery stunt anthracnose. *J Gen Plant Pathol* 81:279–286. <https://doi.org/10.1007/s10327-015-0598-7>
- Yamagishi N, Sato T, Chuma I, Ishiyama Y, Tosa Y (2016) Anthracnose of black locust caused by *Colletotrichum nymphaeae* (Passerini) Aa. *J Gen Plant Pathol* 82:174–176. <https://doi.org/10.1007/s10327-016-0649-8>
- Yan J-Y, Jayawardena MMRS, Goonasekara ID, Wang Y, Zhang W, Liu M, Huang J-B, Wang Z-Y, Shang J-J, Peng Y-L, Bahkali A, Hyde KD, Li X-H (2015) Diverse species of *Colletotrichum* associated with grapevine anthracnose in China. *Fungal Divers* 71:233–246. <https://doi.org/10.1007/s13225-014-0310-9>
- Yang H-C, Haudenschild JS, Hartman GL (2012a) First report of *Colletotrichum chlorophyti* causing soybean Anthracnose. *Plant Dis* 96:1699. <https://doi.org/10.1094/PDIS-06-12-0531-PDN>
- Yang Y, Liu Z, Cai L, Hyde KD (2012b) New species and notes of *Colletotrichum* on daylilies (*Hemerocallis* spp.). *Trop Plant Pathol* 37:165–174. <https://doi.org/10.1590/S1982-56762012000300001>
- Yang H-C, Haudenschild JS, Hartman GL (2014) *Colletotrichum incanum* sp. nov., a curved-conidial species causing soybean anthracnose in USA. *Mycologia* 106:32–42. <https://doi.org/10.3852/13-013>
- Yang XX, Yue SS, Gao LX, Cheng JS, Xie JT, Fu YP (2015) First report of anthracnose caused by *Colletotrichum gloeosporioides* on *Viburnum odoratissimum* in China. *Plant Dis* 77:1647. <https://doi.org/10.1094/PDIS-04-15-0417-PDN>
- Yang XX, Liu Y, Zhang L, Huang XQ, Wu WX, Xue LH (2018) First report of anthracnose caused by *Colletotrichum truncatum* on *Basella alba* in China. *Plant Dis* 102:1853. <https://doi.org/10.1094/PDIS-01-18-0038-PDN>
- Yang S, Wang HX, Yi YJ, Tan LL (2019a) First Report that *Colletotrichum aenigma* Causes Leaf Spots on *Camellia japonica* in China. *Plant Dis* 103:2127. <https://doi.org/10.1094/PDIS-01-19-0224-PDN>
- Yang L, Lu XH, Jing YL, Li SD, Wu BM (2019b) First report of common bean (*Phaseolus vulgaris*) stem rot caused by *Colletotrichum spaethianum* in China. *Plant Dis* 103:151. <https://doi.org/10.1094/PDIS-05-18-0774-PDN>
- Yang B, Jin X, Feng Q, Xiao K, Zhang H, Tang T, Shan L, Guo W (2020) *Colletotrichum* species causing leaf spot diseases of *Liriope cymbidioromorpha* (ined.) in China. *Australasian Plant Pathol* 49:137–139. <https://doi.org/10.1007/s13313-020-00683-y>
- Yang H, Cao G, Jiang S, Han S, Yang C, Wan X, Zhang F, Chen L, Xiao J, Zhu P, Zhang D, He F, Xing W (2021) Identification of the anthracnose fungus of walnut (*Juglans* spp.) and resistance evaluation through physiological responses of resistant vs. susceptible hosts. *Plant Pathol* 70:1219–1229. <https://doi.org/10.1111/ppa.13354>
- Ye Y, Qin L, Jiang S, Wei J, Cui Y, Powell CA, Zhang M (2016) First report of anthracnose caused by *Colletotrichum siamense* on *Sarcandra glabra* in China. *Plant Dis* 100:862. <https://doi.org/10.1094/PDIS-01-15-0092-PDN>
- Youlian Y, Cai L, Yu Z, Liu Z, Hyde KD (2011) *Colletotrichum* species on Orchidaceae in Southwest China. *Cryptogam Mycol* 32:229–253. <https://doi.org/10.7872/crym.v32.iss3.2011.229>
- Yu J, Wu J, Guo Z, Zhang X, Xu M, Yu J, Liu T, Chi Y (2020) First report of peanut Anthracnose caused by *Colletotrichum truncatum* in China. *Plant Dis* 104:1555. <https://doi.org/10.1094/PDIS-08-19-1599-PDN>
- Yuan H-S, Lu X, Dai Y-C, Hyde KD, Kan Y-H, Kušan I, He S-H, Liu N-G, Sarma VV, Zhao C-L, Cui B-K, Yousaf N, Sun G, Liu S-Y, Wu F, Lin C-G, Dayarathne MC, Gibertoni TB, Conceição LB, Garibay-Orijel R, Villegas-Ríos M, Salas-Lizana R, Wei T-Z, Qiu J-Z, Yu Z-F, Phookamsak R, Zeng M, Paloi S, Bao D-F, Abeywickrama PD, Wei D-P, Yang J, Manawasinghe IS, Harishchandra D, Brahmanage RS, Silva NI, Tennakoon DS, Karunarithna A, Gafforov Y, Pem D, Zhang S-N, Santiago ALMCA, Bezerra JDP, Dima B, Acharya K, Alvarez-Manjarrez J, Bahkali AH, Bhatt VK, Brandrud TE, Bulgakov TS, Camporesi E, Cao T, Chen Y-X, Chen Y-Y, Devadatha B, Elgorban AM, Fan L-F, Du X, Gao L, Gonçalves CM, Gusmão LFP, Huanraluek N, Jadan M, Jayawardena RS, Khalid AN, Langer E, Lima DX, Lima-Júnior NC, Lira CRS, Liu J-K, Liu S, Lumyoung S, Luo Z-L, Matočec N, Niranjan M, Oliveira-Filho JRC, Papp V, Pérez-Pazos E, Phillips AJL, Qiu P-L, Ren Y, Castañeda Ruiz RF, Semwal KC, Soop K, Souza CAF, Souza-Motta CM, Sun L-H, Xie M-L, Yao Y-J, Zhao Q, Zhou L-W (2020) Fungal diversity notes 1277–1386: taxonomic and phylogenetic contributions to fungal tax. *Fungal Divers* 104:1–266. <https://doi.org/10.1007/s13225-020-00461-7>
- Zapata M, Opazo A (2017) Detection of *Colletotrichum pyricola* on urban trees of *Embothrium coccineum* in Chile. *Bosque* 38:195–201. <https://doi.org/10.4067/S0717-92002017000100019>
- Zapparata A, Da Lio D, Sarrocco S, Vannacci G, Baroncelli R (2017) First report of *Colletotrichum godetiae* causing grape (*Vitis vinifera*) berry rot in Italy. *Plant Dis* 101:1051. <https://doi.org/10.1094/PDIS-12-16-1764-PDN>
- Zaw M, Aye SS, Matsumoto M (2020) *Colletotrichum* and *Diaporthe* species associated with soybean stem diseases in Myanmar. *J Gen Plant Pathol* 86:114–123. <https://doi.org/10.1007/s10327-019-00902-5>
- Zhafarina S, Wibowo A, Widiastuti A (2021) Multi-genetic analysis of *Colletotrichum* spp. associated with postharvest disease of fruits Anthracnose in special region of Yogyakarta, Indonesia. *Pak J Biol Sci* 24:53–65. <https://doi.org/10.3923/pjbs.2021.53.65>
- Zhai YX, Zhang BQ, Cao H, Hao XJ (2018) First report of *Colletotrichum truncatum* causing Anthracnose of *Begonia* in China. *Plant Dis* 102:1177. <https://doi.org/10.1094/PDIS-10-17-1520-PDN>
- Zhang CQ, Dai DJ (2017) First report of Anthracnose in Baishao (*Radix paeoniae alba*) caused by *Colletotrichum gloeosporioides* in China. *Plant Dis* 101:504. <https://doi.org/10.1094/PDIS-08-16-1097-PDN>
- Zhang J, Zhu TH (2018) First report of *Colletotrichum boninense* causing leaf Anthracnose on *Eucalyptus robusta* (Smith) in the upper reaches of Yangtze River. *Plant Dis* 102:1446. <https://doi.org/10.1094/PDIS-07-17-1043-PDN>
- Zhang FF, Wang MZ, Zheng YX, Liu HY, Zhang XQ, Wu SS (2015) Isolation and characterization of endophytic Huperzine A-producing fungi from *Phlegmariurus phlegmaria*. *Microbiology* 84:701–709. <https://doi.org/10.1134/S0026261715050185>
- Zhang JN, Song LM, Liang WX, Li DL (2017) First report of *Colletotrichum gloeosporioides* causing leaf spots on *Smilax*

- sieboldii* in China. Plant Dis 101:2150. <https://doi.org/10.1094/PDIS-06-17-0810-PDN>
- Zhang L, Yang XX, Huang XQ, Wu WX, Liu Y, Xue LH (2018a) First report of Anthracnose on *Michelia champaca* caused by *Colletotrichum fioriniae* in China. Plant Dis 102:2040. <https://doi.org/10.1094/PDIS-02-18-0348-PDN>
- Zhang YW, Xue LH, Li CJ (2018b) First report of Anthracnose caused by *Colletotrichum higginsianum* on *Rumex acetosa* in China. Plant Dis 102:1174. <https://doi.org/10.1094/PDIS-07-17-1082-PDN>
- Zhang Y, Xu H, Jiang S, Wang F, Ou C, Zhao Y, Ma L, Li Y (2018c) First report of *Colletotrichum truncatum* causing Anthracnose on the berry stalk and the Rachis of Kyoho Grape (*Vitis labruscana* × *V. vinifera*) clusters in Hebei. China. Plant Dis 102:2040. <https://doi.org/10.1094/PDIS-02-18-0275-PDN>
- Zhang YB, Meng K, Shu JP, Zhang W, Wang HJ (2019a) First report of Anthracnose on pecan (*Carya illinoensis*) caused by *Colletotrichum nymphaeae* in China. Plant Dis 103:1432. <https://doi.org/10.1094/PDIS-11-18-1968-PDN>
- Zhang YL, Wang JY, Yin CP, Mao ZC, Shao Y (2019b) First report of *Colletotrichum siamense* causing Anthracnose on *Jasminum mesnyi* in China. Plant Dis 103:2675. <https://doi.org/10.1094/PDIS-04-19-0804-PDN>
- Zhang Y, Shen R, Mo Y, Li Q, Lin W, Yuan G (2020a) *Colletotrichum siamense*: a novel leaf pathogen of *Sterculia nobilis* Smith detected in China. For Pathol 50:e12575. <https://doi.org/10.1111/efp.12575>
- Zhang Y, Long D, Wang J, Li Q, Wang Z, Lin W, Yuan G (2020b) Morphological and molecular identification of *Colletotrichum siamense*, a novel leaf pathogen associated with *Sterculia lanceolata* recorded in China. J Phytopathol 168:451–459. <https://doi.org/10.1111/jph.12909>
- Zhang W, Damm U, Crous PW, Groenewald JZ, Niu X, Lin J, Li Y (2020c) Anthracnose disease of carpetgrass (*Axonopus compressus*) caused by *Colletotrichum hainanense* sp. nov. Plant Dis 104:1744–1750. <https://doi.org/10.1094/PDIS-10-19-2183-RE>
- Zhang H, Wei Y, Shi H (2020d) First report of anthracnose caused by *Colletotrichum kahawae* subsp. *ciggaro* on *Areca* in China. Plant Dis 104:1871. <https://doi.org/10.1094/PDIS-12-19-2628-PDN>
- Zhang Y, Sun W, Ning P, Guo T, Huang S, Tang L, Li Q, Mo J (2021a) First report of Anthracnose of papaya (*Carica papaya* L.) caused by *Colletotrichum siamense* in China. Plant Dis. <https://doi.org/10.1094/pdis-10-20-2154-pdn> (in press)
- Zhang Z, Yan M, Li W, Guo Y, Liang X (2021b) First report of *Colletotrichum aenigma* causing apple Glomerella leaf spot on the Granny Smith cultivar in China. Plant Dis. <https://doi.org/10.1094/pdis-10-20-2298-pdn> (in press)
- Zhang Y, Li G, Yang D, Zhang R, Wan S (2021c) First report of *Colletotrichum fioriniae* causing anthracnose on mu oil tree in China. Plant Dis. <https://doi.org/10.1094/PDIS-03-21-0502-PDN> (in press)
- Zhang M-Y, Si Y-Z, Ju Y, Li D-W, Zhu L-H (2021d) First report of leaf spot caused by *Colletotrichum siamense* on *Salix matsudana* in China. Plant Dis. <https://doi.org/10.1094/PDIS-04-21-0776-PDN> (in press)
- Zhao W, Wang T, Chen QQ, Chi YK, Swe TM, Qi RD (2016a) First report of *Colletotrichum scovillei* causing Anthracnose fruit rot on pepper in Anhui Province. China Plant Dis 100:2168. <https://doi.org/10.1094/PDIS-04-16-0443-PDN>
- Zhao W, Wang T, Chen QQ, Chi YK, Swe TM, Qi RD (2016b) First report of leaf spot caused by *Colletotrichum spaethianum* on *Lilium lancifolium* in China. Plant Dis 100:2328. <https://doi.org/10.1094/PDIS-04-16-0517-PDN>
- Zhao HJ, Chen SC, Chen YF, Zou CC, Wang XL, Wang ZH, Liu AR, Ahammed GJ (2018) First report of red dragon fruit (*Hylocereus polyrhizus*) Anthracnose caused by *Colletotrichum siamense* in China. Plant Dis 102:1175. <https://doi.org/10.1094/PDIS-08-17-1193-PDN>
- Zhao C, Sun H, Zhao Y, Huang J (2019) First report of *Colletotrichum gloeosporioides* causing leaf spot disease on *Hymenocallis littoralis* in China. Plant Dis 103:3286. <https://doi.org/10.1094/PDIS-06-19-1236-PDN>
- Zhao XY, Wu F, Chen M, Li SC, Zhang YN, Fu YQ, Yu GY, Xiang ML (2020) First report of *Colletotrichum siamense* causing leaf spot on *Parthenocissus tricuspidata* in China. Plant Dis 104:2290. <https://doi.org/10.1094/PDIS-12-19-2535-PDN>
- Zhao J, Liu T, Zhang DP, Wu HL, Pan LQ, Liao NY, Liu WC (2021a) First report of Anthracnose caused by *Colletotrichum siamense* and *C. fruticola* of *Camellia chrysantha* in China. Plant Dis. <https://doi.org/10.1094/pdis-11-20-2324-pdn> (in press)
- Zhao N, Yang J, Fang X, Li L, Yan H, Liu D (2021b) First report of *Colletotrichum cereale* causing Anthracnose on *Avena nuda* in China. Plant Dis 105:1126. <https://doi.org/10.1094/pdis-10-20-2109-pdn>
- Zhao J, Yu Z, Wang Y, Li Q, Tang L, Guo T, Huang SP, Mo J, Hsiang T (2021c) Litchi anthracnose caused by *Colletotrichum karstii* in Guangxi, China. Plant Dis. <https://doi.org/10.1094/PDIS-01-21-0196-PDN> (in press)
- Zheng X, Tan L-T, Cheng S, Liang P-Y, Fang L, Medison RG, Zhou Y, Sun Z-X (2021a) First report of Anthracnose on *Rubus rosaefolius* Smith caused by *Colletotrichum boninense* in China. Plant Dis. <https://doi.org/10.1094/pdis-06-20-1309-pdn> (in press)
- Zheng X-R, Zhang M-J, Shang X-L, Fang S-Z, Chen F-M (2021b) Etiology of *Cyclocarya paliurus* Anthracnose in Jiangsu Province, China. Front Plant Sci 11:613499. <https://doi.org/10.3389/fpls.2020.613499>
- Zhong J, Li CX, Zhong SY, Hu Z (2020) First report of leaf spot caused by *Colletotrichum spaethianum* on *Paris polyphylla* in China. Plant Dis 104:972. <https://doi.org/10.1094/PDIS-09-19-1844-PDN>
- Zhou RJ, Yuan Y, Xu HJ, Fu JF, Ou YH (2014) First report of Anthracnose of *Malva sylvestris* caused by *Colletotrichum trifolii* in China. Plant Dis 98:1587. <https://doi.org/10.1094/PDIS-06-14-0611-PDN>
- Zhou Z, Li YL, Yuan CY (2016) First report of *Colletotrichum siamense* causing Anthracnose on *Cinnamomum kotoense* in Henan Province, China. Plant Dis 100:2330. <https://doi.org/10.1094/PDIS-05-16-0649-PDN>
- Zhou Y, Huang JS, Yang LY, Wang GF, Li JQ (2017) First report of banana Anthracnose caused by *Colletotrichum scovillei* in China. Plant Dis 101:381. <https://doi.org/10.1094/PDIS-08-16-1135-PDN>
- Zhou S, Qiao L, Jayawardena RS, Hyde KD, Ma X, Wen T, Kang J (2019) Two new endophytic *Colletotrichum* species from *Nothapodytes pittosporoides* in China. MycoKeys 49:1–14. <https://doi.org/10.3897/mycokeys.49.31904>
- Zhu YZ, Liao WJ, Zou DX, Wu YJ, Zhou Y (2015) First report of leaf spot disease on walnut caused by *Colletotrichum fioriniae* in China. Plant Dis 99:289. <https://doi.org/10.1094/PDIS-09-14-0938-PDN>
- Zhu L-H, Wan Y, Zhu Y-N, Huang L, Liu C-L, Li D-W (2019a) First report of species of *Colletotrichum* causing leaf spot of *Liriodendron chinense* × *tulipifera* in China. Plant Dis 103:1431. <https://doi.org/10.1094/PDIS-12-18-2265-PDN>
- Zhu J, Ren Z, Cao A, Yan D, Fang W, Huang B, Guo M, Ouyang C, Li Y (2019b) First report of Anthracnose caused by *Colletotrichum gloeosporioides* on *Mikania micrantha* in Guangdong, China. Plant Dis 103:161. <https://doi.org/10.1094/PDIS-07-18-1210-PDN>
- Zhu LH, Jin GQ, Sun DL, Wan Y, Li DW (2020) First report of *Colletotrichum gloeosporioides* sensu stricto causing leaf Blotch on *Acer coriaceifolium* in China. Plant Dis 104:983. <https://doi.org/10.1094/PDIS-08-19-1716-PDN>
- Zimowska B, Zalewska ED, Król ED (2016) Occurrence and characterization of *Colletotrichum fuscum*. Acta Sci Pol Hort Cult 15:121–134
- Živković S, Gavrilović V, Popović T, Dolovac N, Trkulja N (2014) First report of *Colletotrichum clavatum* causing Quince Anthracnose in Serbia. Plant Dis 98:1272. <https://doi.org/10.1094/PDIS-01-14-0052-PDN>