

ÁREA DE ESTUDO



ÁREAS DE INTERVENÇÃO



- 1 EIXO TRANSVERSAL DE PENHA FRANÇA
- 2 EIXO TRANSVERSAL DE VALE DE CHELAS
- 3 EIXO TRANSVERSAL DE BRAÇO DE PRATA

ESTRUTURA ECOLÓGICA

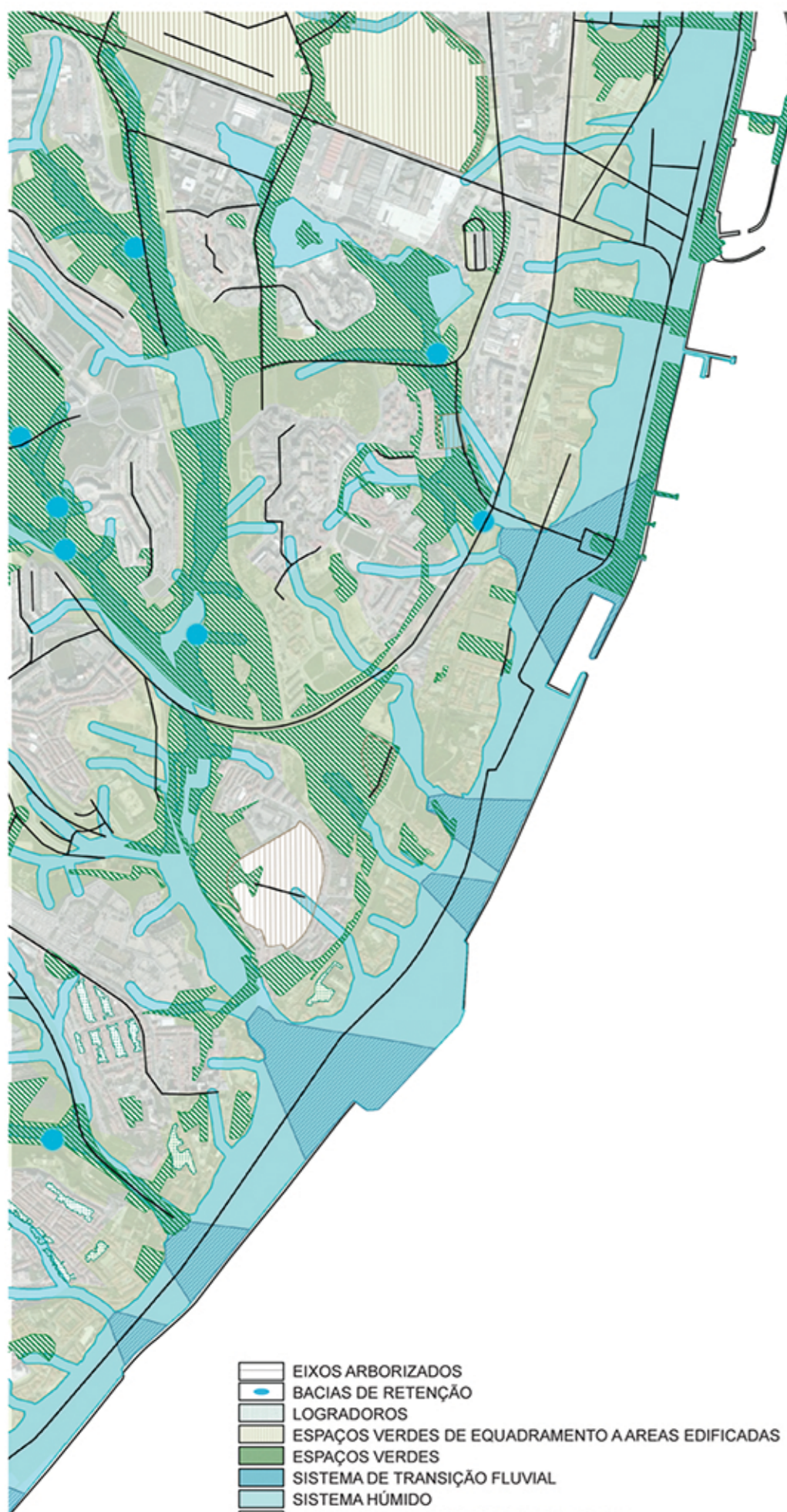

- EIXOS ARBORIZADOS
- BACIAS DE RETENÇÃO
- LOGRADOROS
- ESPAÇOS VERDES DE EQUADRAMENTO A ÁREAS EDIFICADAS
- ESPAÇOS VERDES
- SISTEMA DE TRANSIÇÃO FLUVIAL
- SISTEMA HÚMIDO
- SISTEMA CORREDORES ESTRUTURANTES

0 500 1000 m

REDE DE TRANSPORTES



- AUTOCARRO
- LINHA FERROVIÁRIA
- PARAGEM TERMINAL AUTOCARRO
- CONTINUAÇÃO DE CARREIRA AUTOCARRO

0 500 1000 m

REDE VIÁRIA

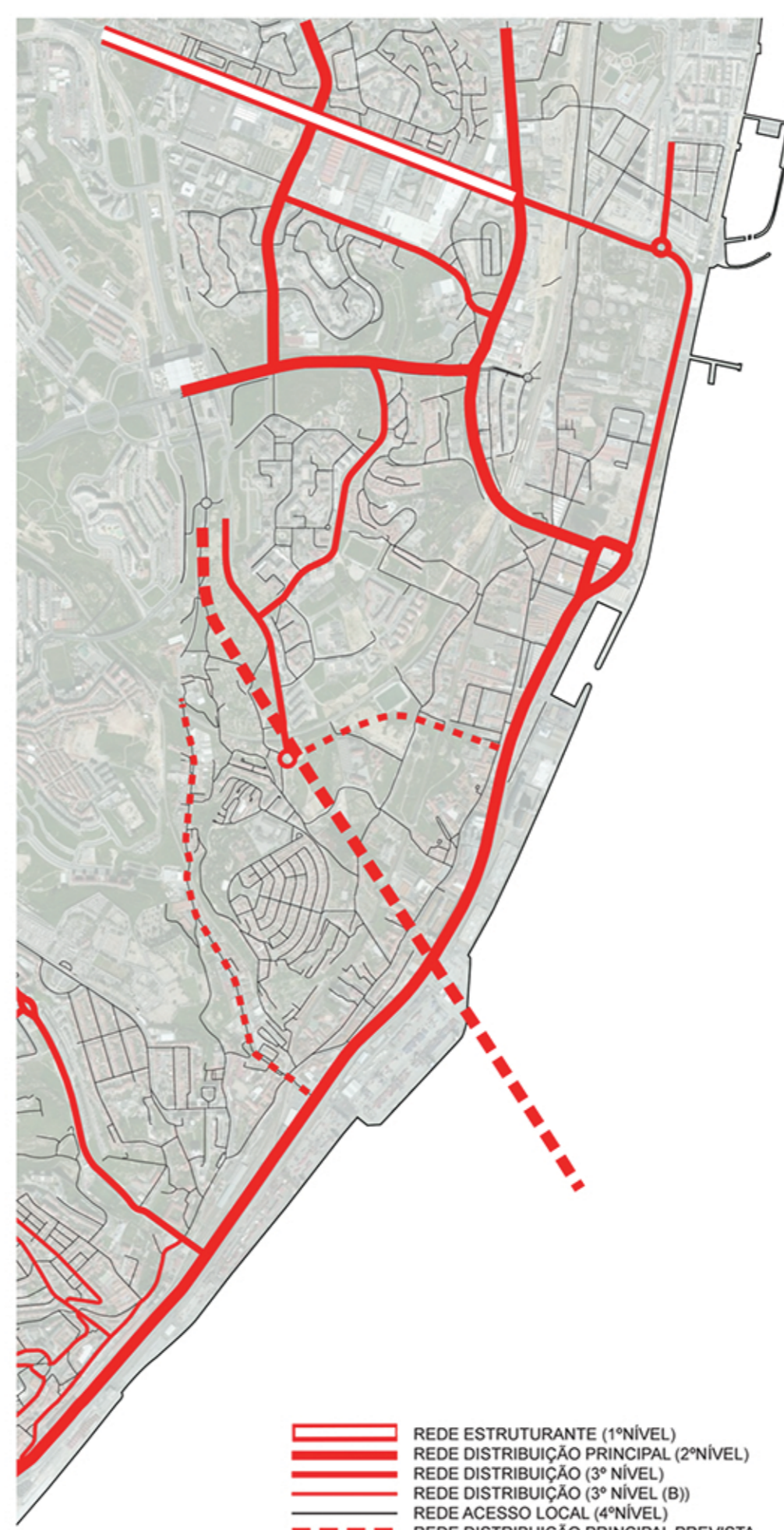

- REDE ESTRUTURANTE (1º NÍVEL)
- REDE DISTRIBUIÇÃO PRINCIPAL (2º NÍVEL)
- REDE DISTRIBUIÇÃO (3º NÍVEL)
- REDE DISTRIBUIÇÃO (3º NÍVEL (B))
- REDE ACESSO LOCAL (4º NÍVEL)
- REDE DISTRIBUIÇÃO PRINCIPAL PREVISTA
- REDE DISTRIBUIÇÃO SECUNDÁRIA PREVISTA

0 500 1000 m

LEVANTAMENTO DE EQUIPAMENTOS



- EQUIPAMENTOS CULTURAIS
- EQUIPAMENTOS DESPORTIVOS
- EQUIPAMENTOS EDUCATIVOS
- EQUIPAMENTOS DE SAÚDE
- LINHA FERROVIÁRIA

0 500 1000 m

ANÁLISE HISTÓRICA

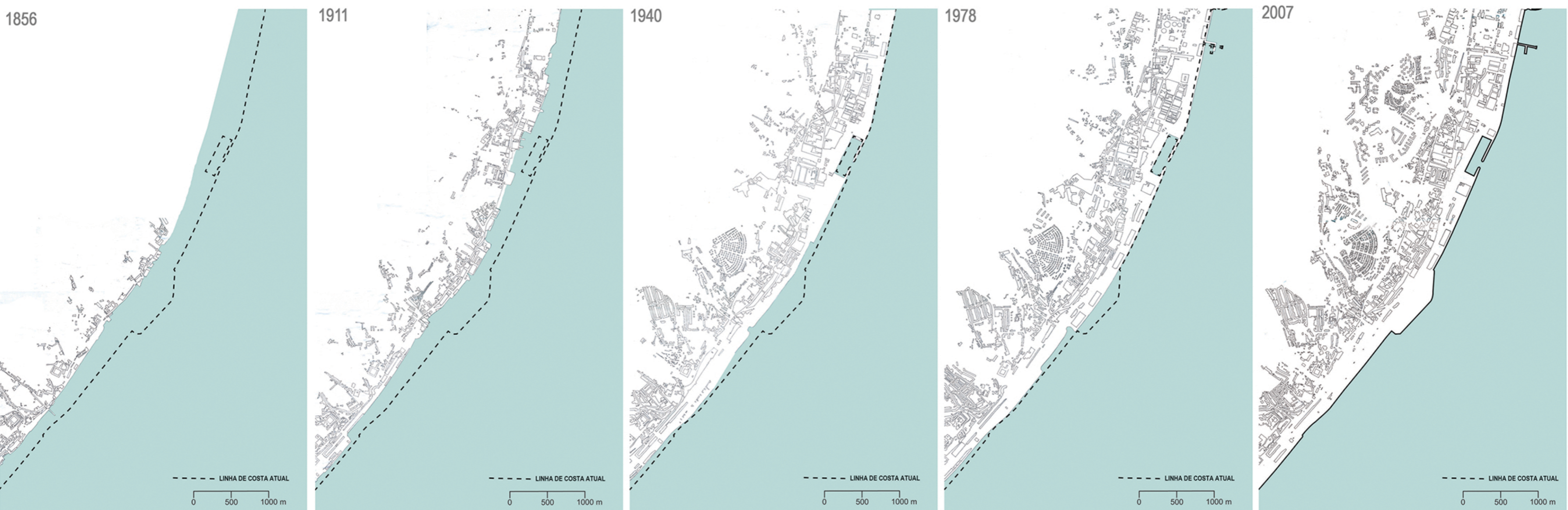

ESTRATÉGIA PARA O TERRITÓRIO DE PENHA FRANÇA, VALE DE CHELAS E BRAÇO DE PRATA

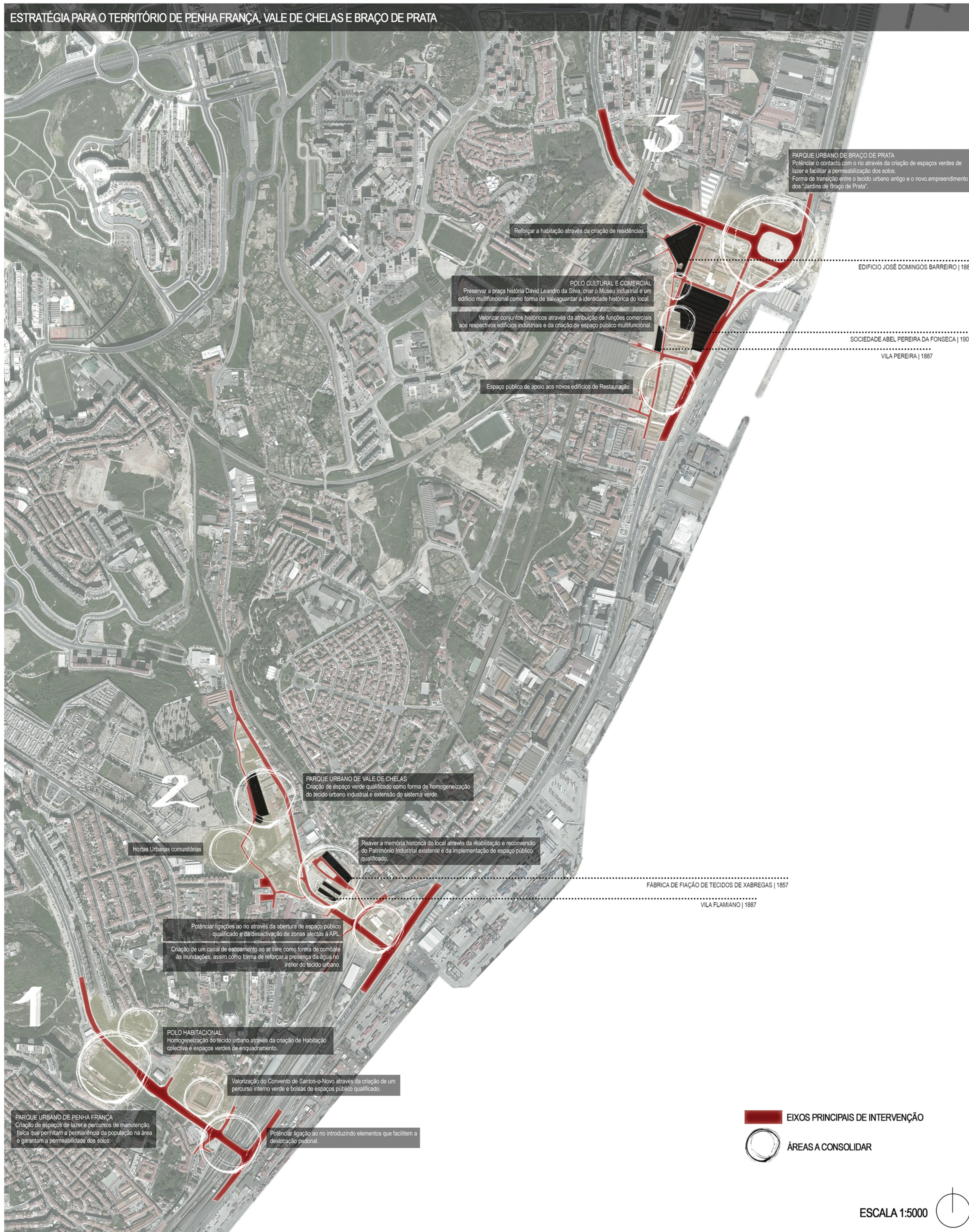

ESCALA 1:5000



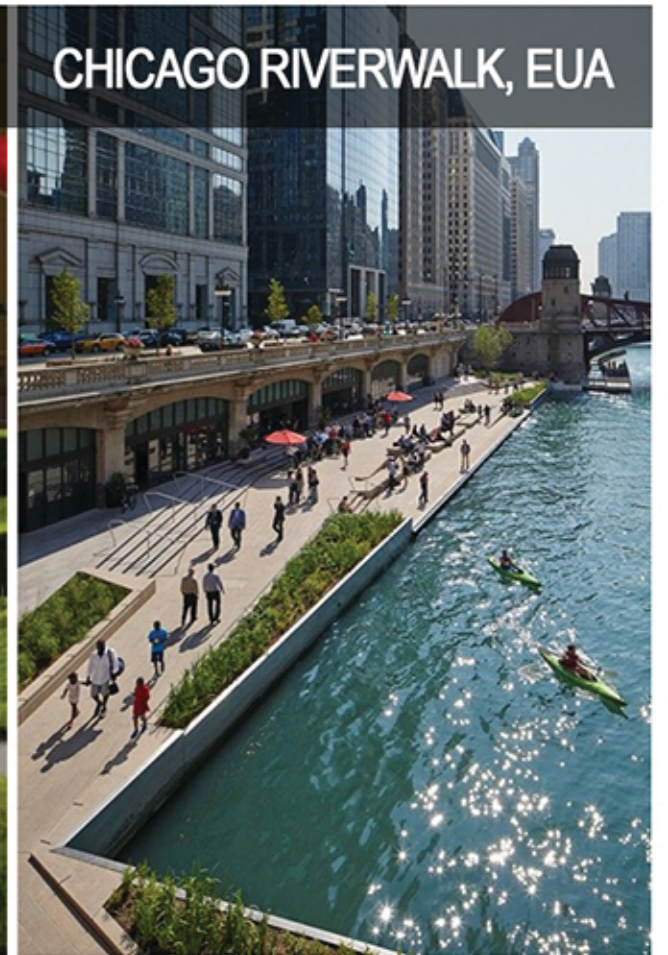
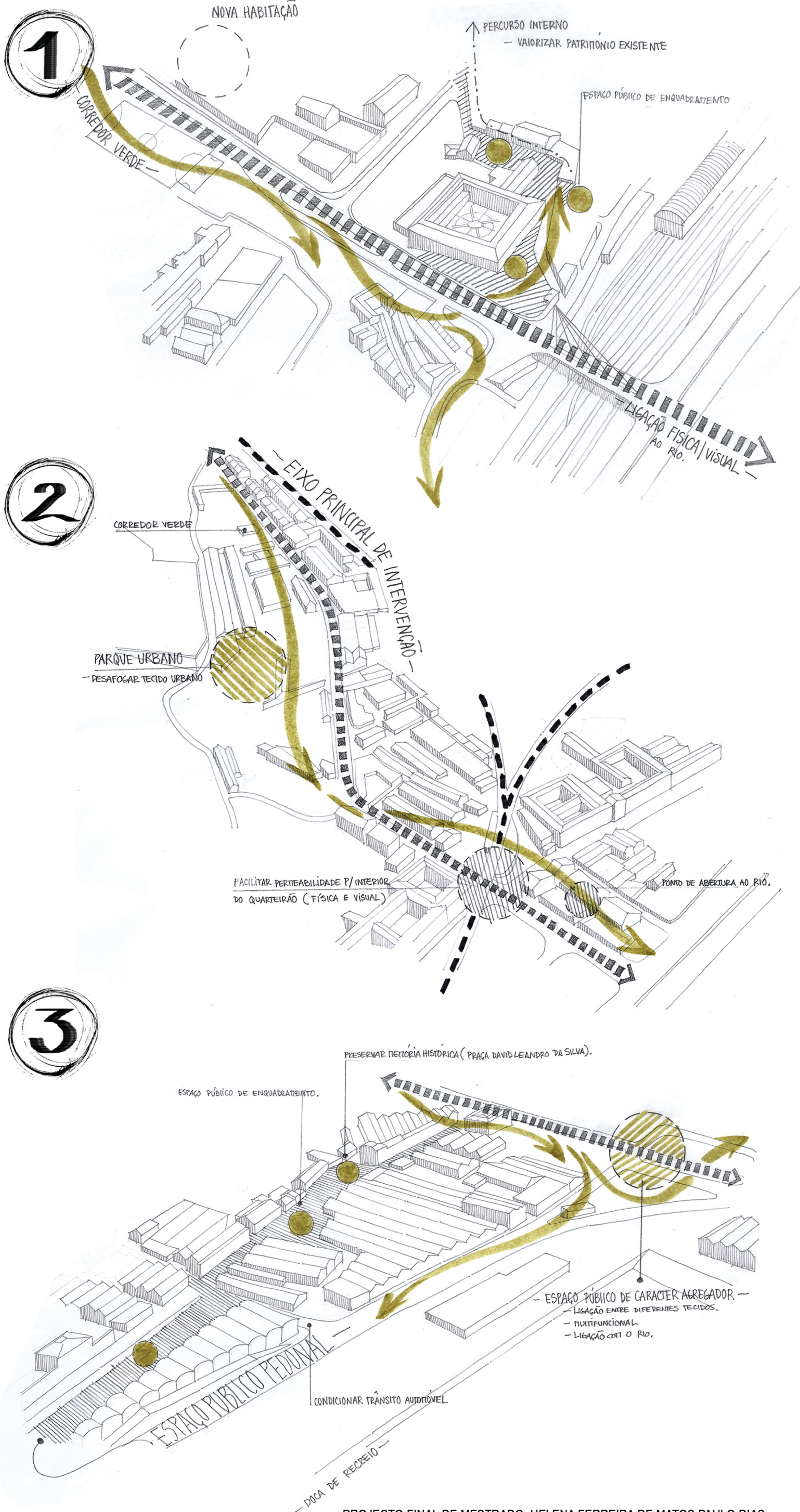



PROPOSTA URBANA DE VALE DE CHELAS | ESCALA 1:1000

PROCESSO DE TRABALHO PRIMEIRO E ÚLTIMO ESQÜISSOS DE ABORDAGEM AO PROJECTO

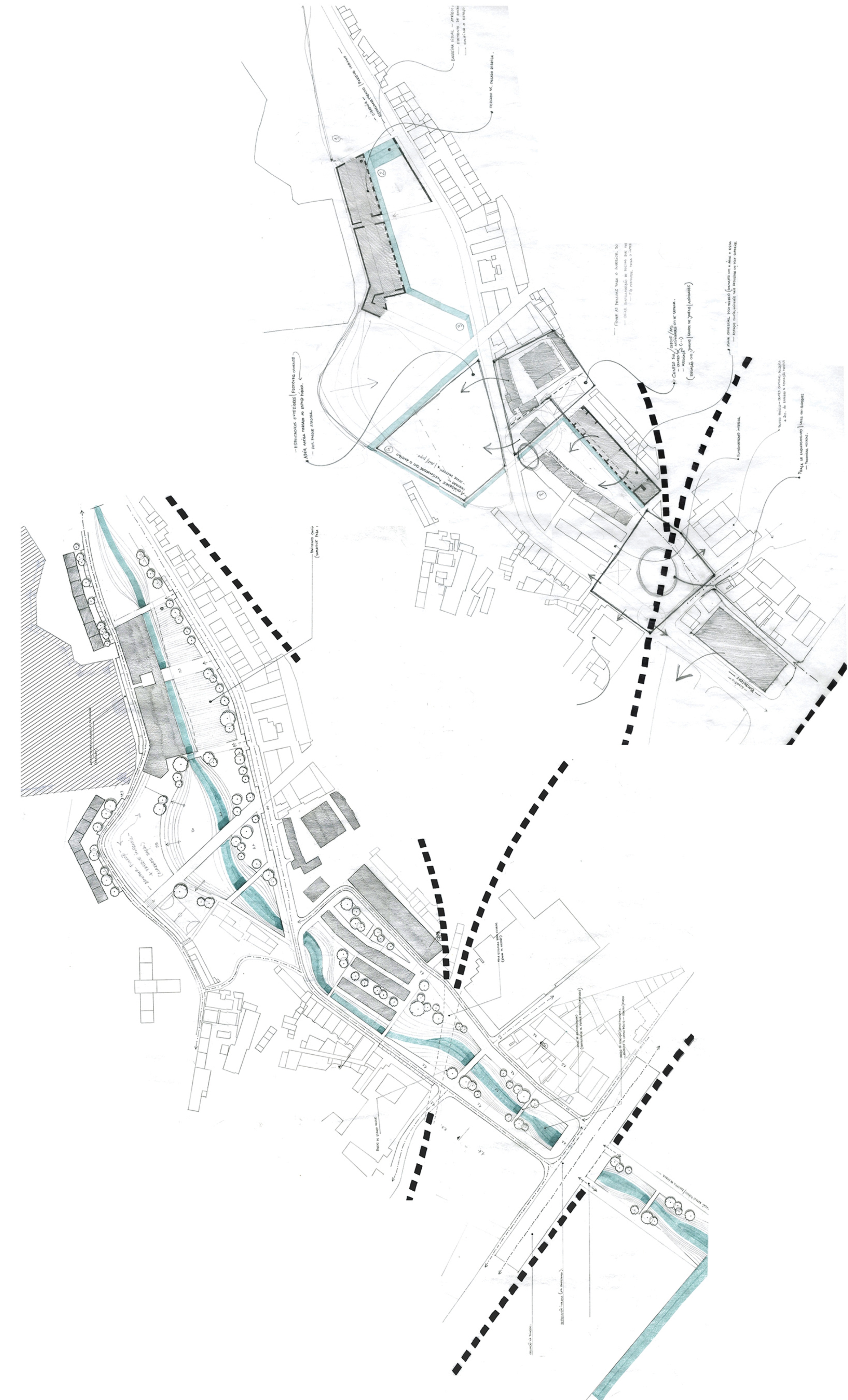

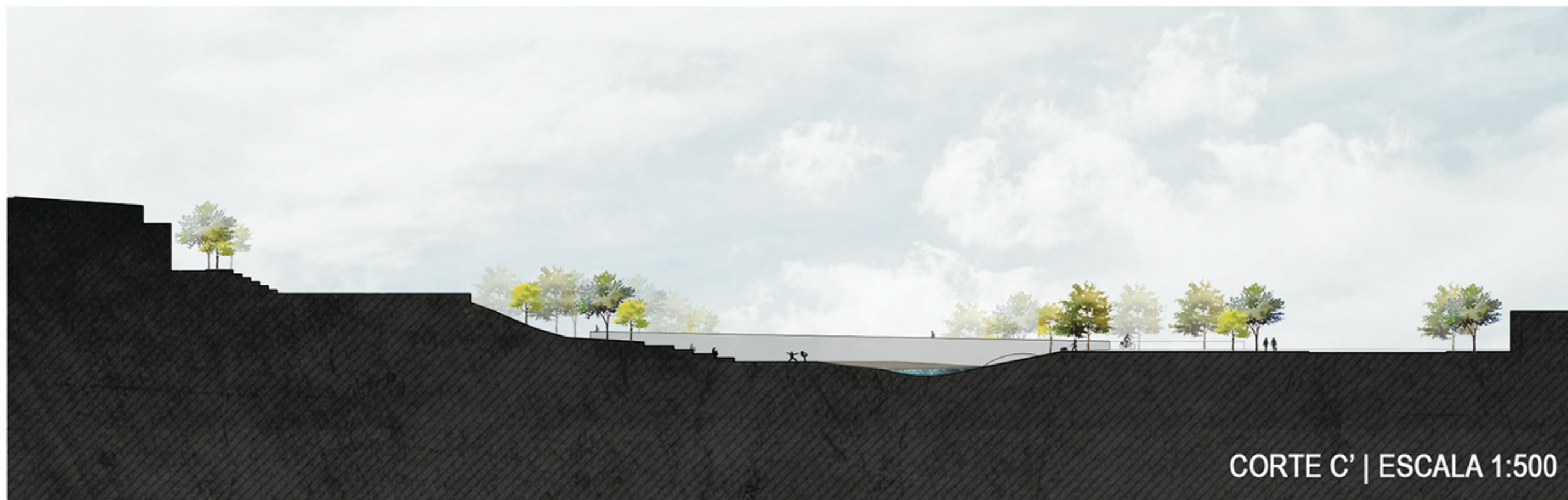
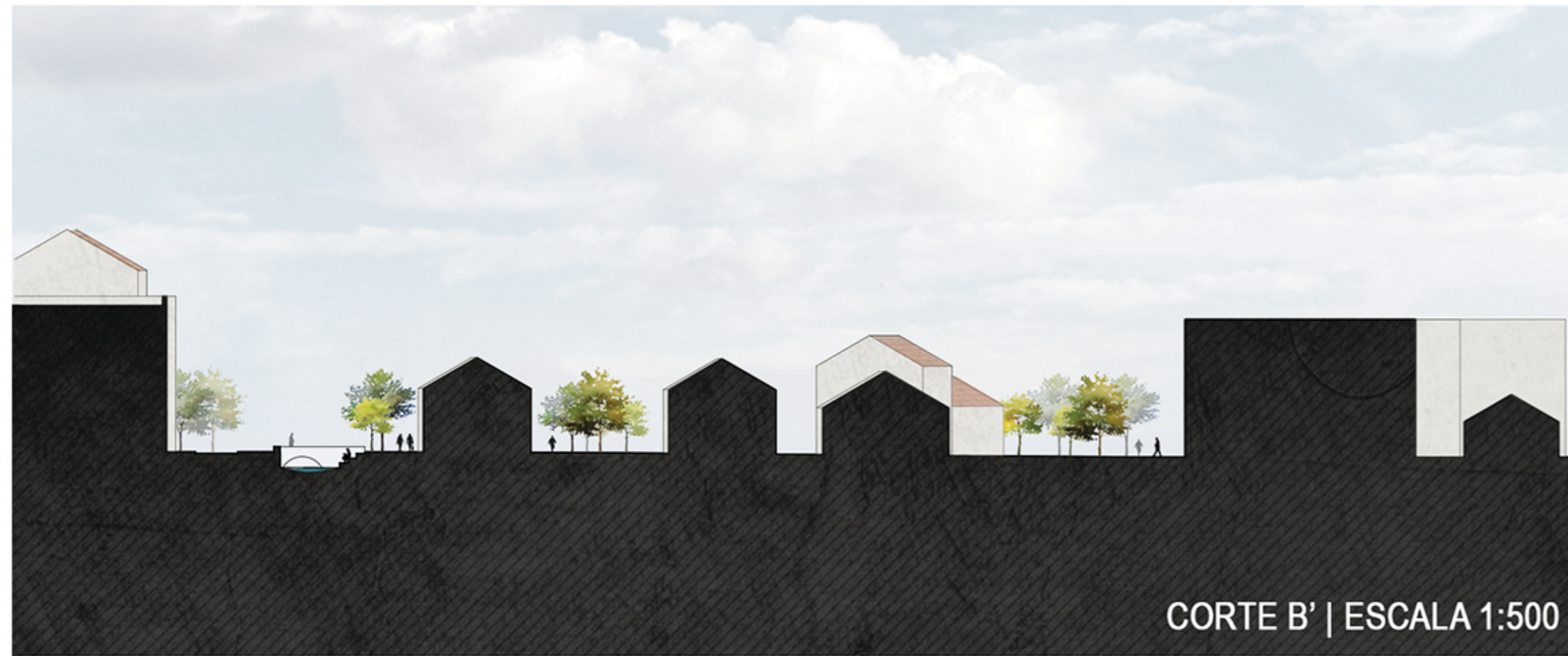

PROCESSO DE TRABALHO

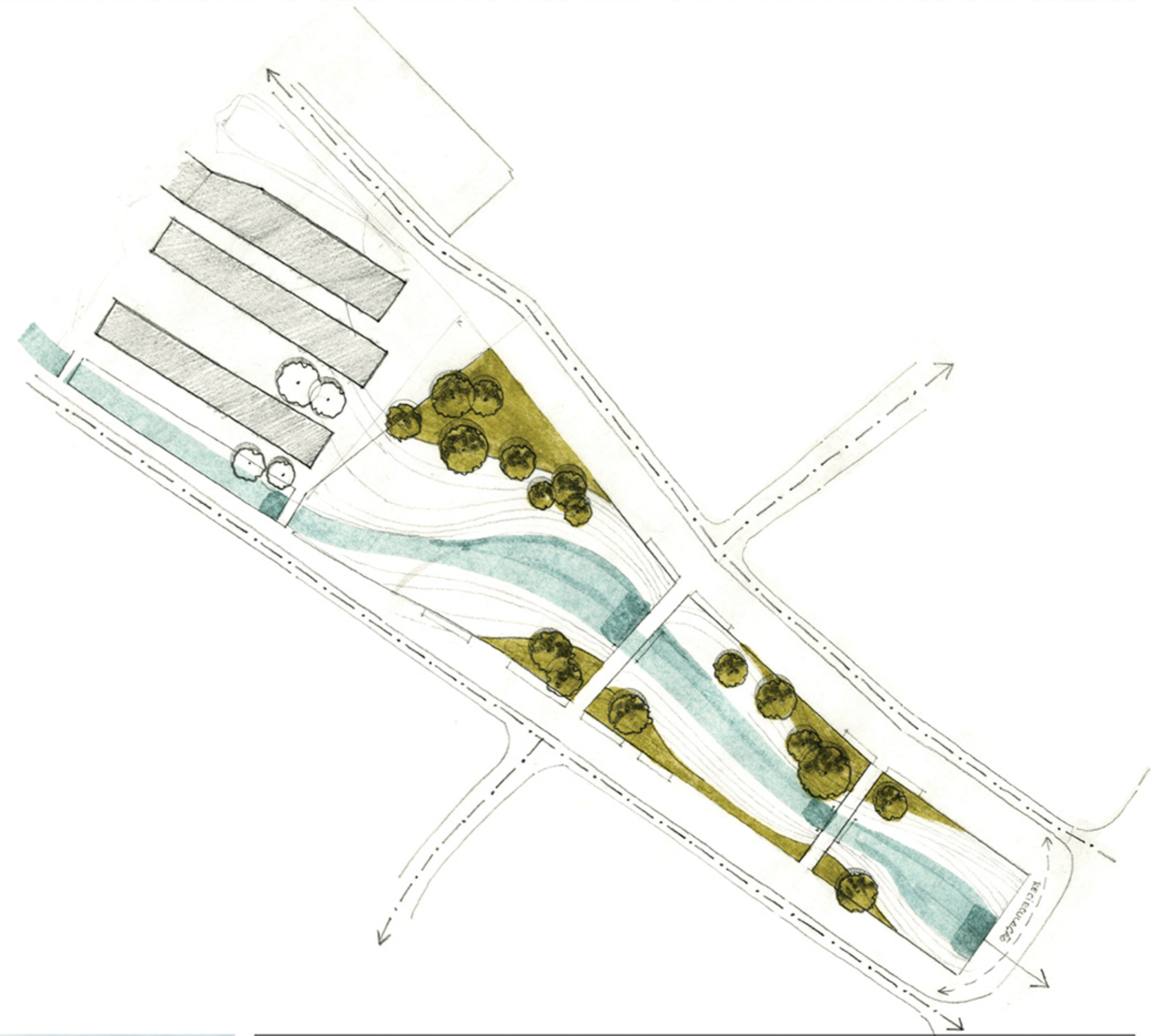

CORTE ESQUEMÁTICO VALORIZAÇÃO DO CAMINHO PEDONAL

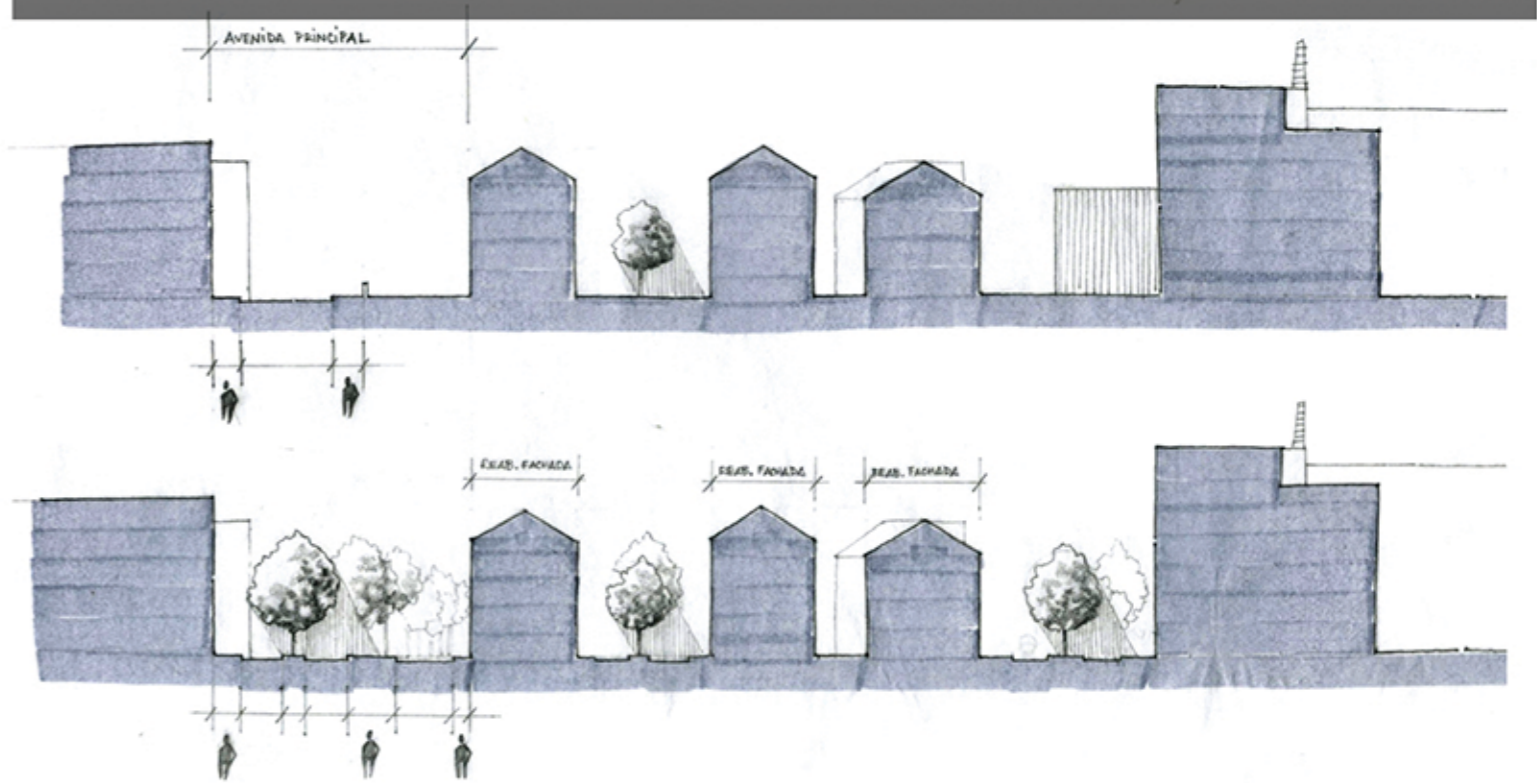

USOS PROPOSTOS

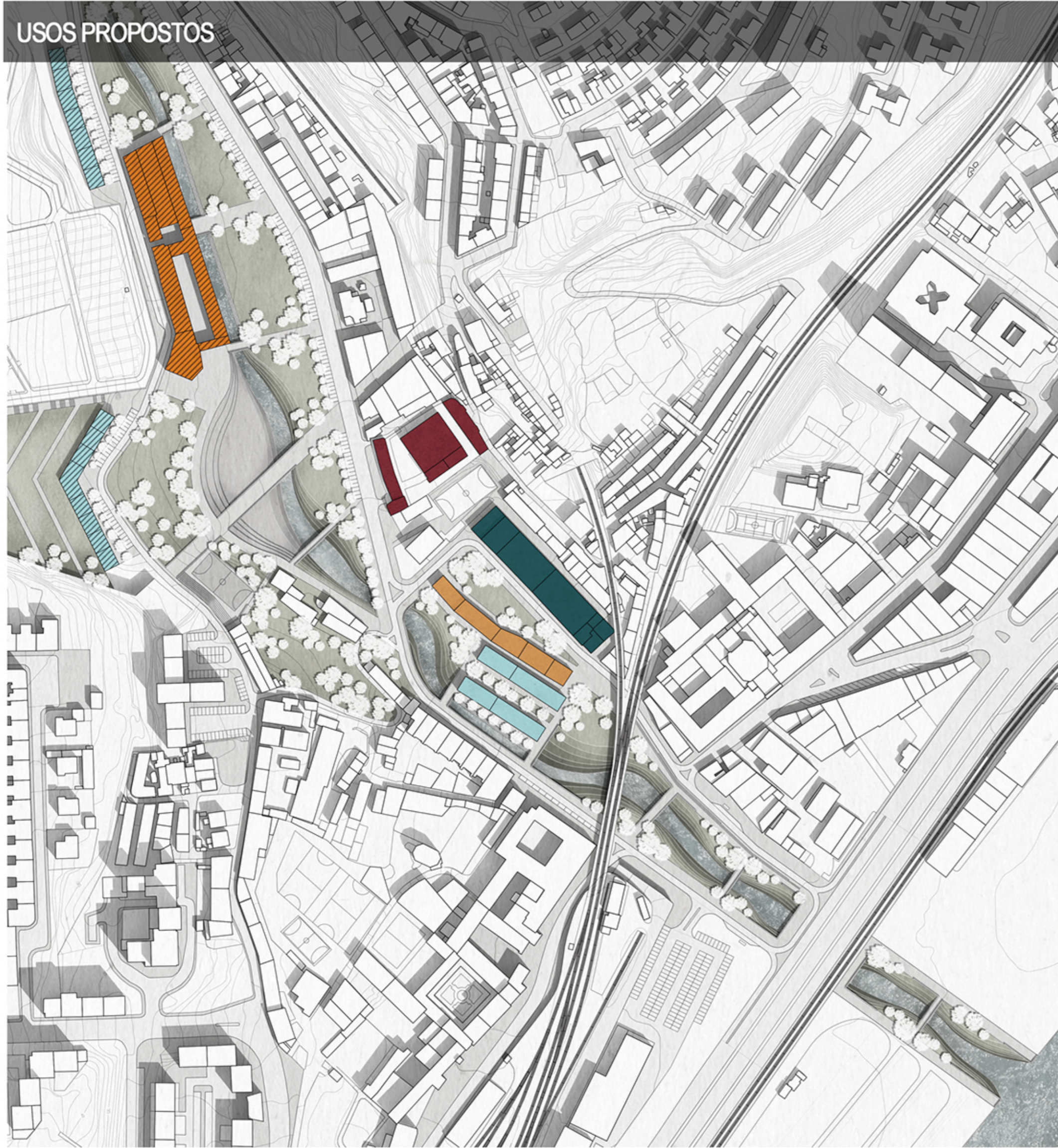

- CONSTRUÇÃO**
- HABITAÇÃO
 - MISTO 1 (COMÉRCIO, RESTAURAÇÃO, SERVIÇOS)
- REABILITAÇÃO**
- HABITAÇÃO
 - MISTO 2 (ESCRITÓRIOS, COMÉRCIO, SERVIÇOS)
 - COMÉRCIO
 - ASSOCIAÇÃO

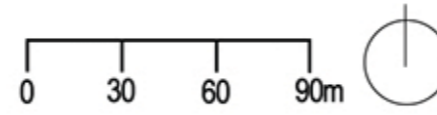

ESPAÇOS PROPOSTOS

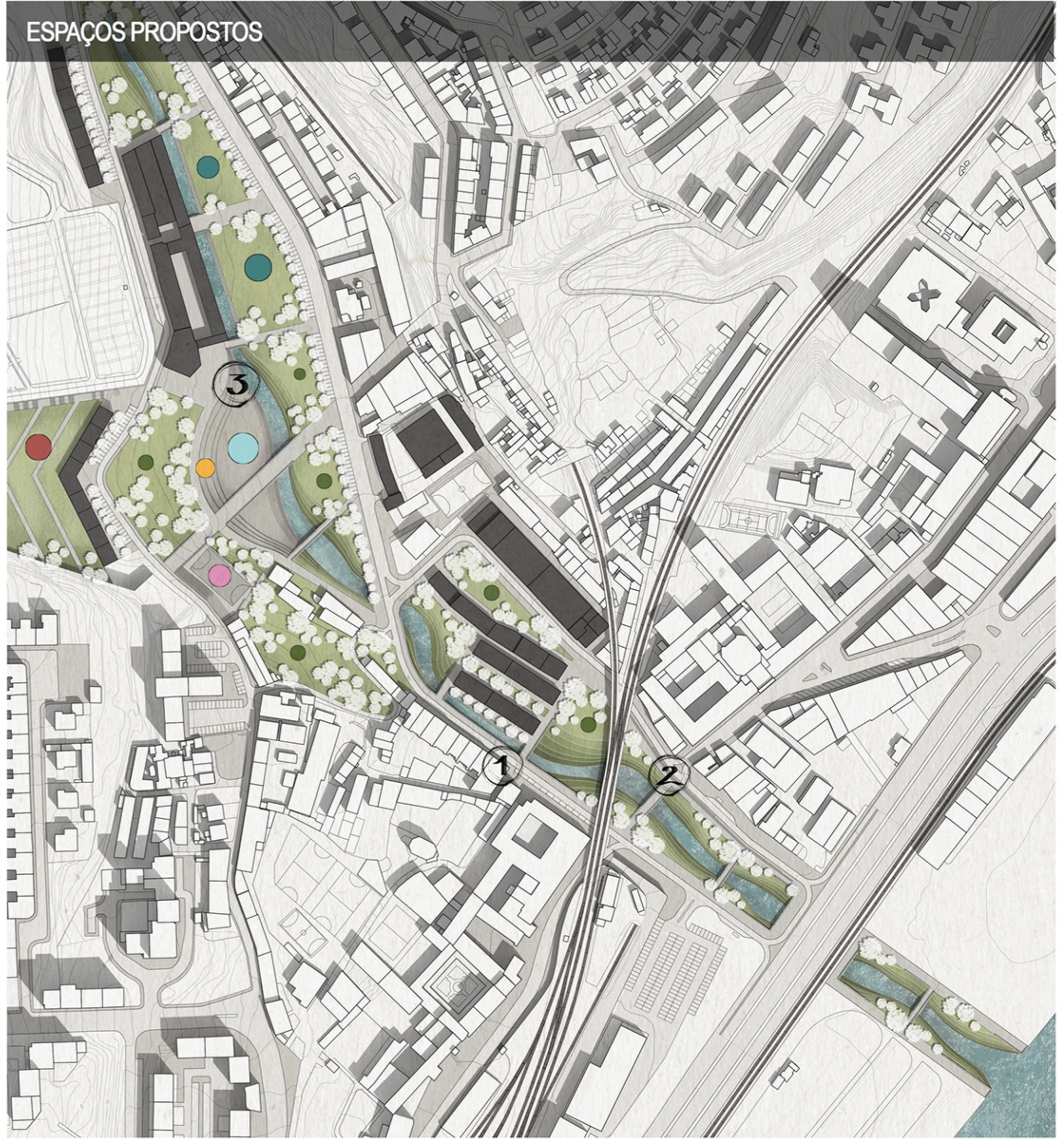

- PRACA DE ÁGUA INUNDÁVEL
- ESPAÇOS MULTIFUNCAIONAIS (EXTENSÃO DO MERCADO E/OU FEIRAS)
- ESPAÇOS VERDES E/OU ARBORIZADOS
- AUDITÓRIO
- CAMPO DE JOGOS
- HORTAS URBANAS

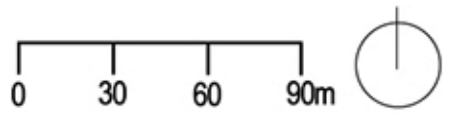

SENTIDO DE TRÂNSITO PROPOSTO

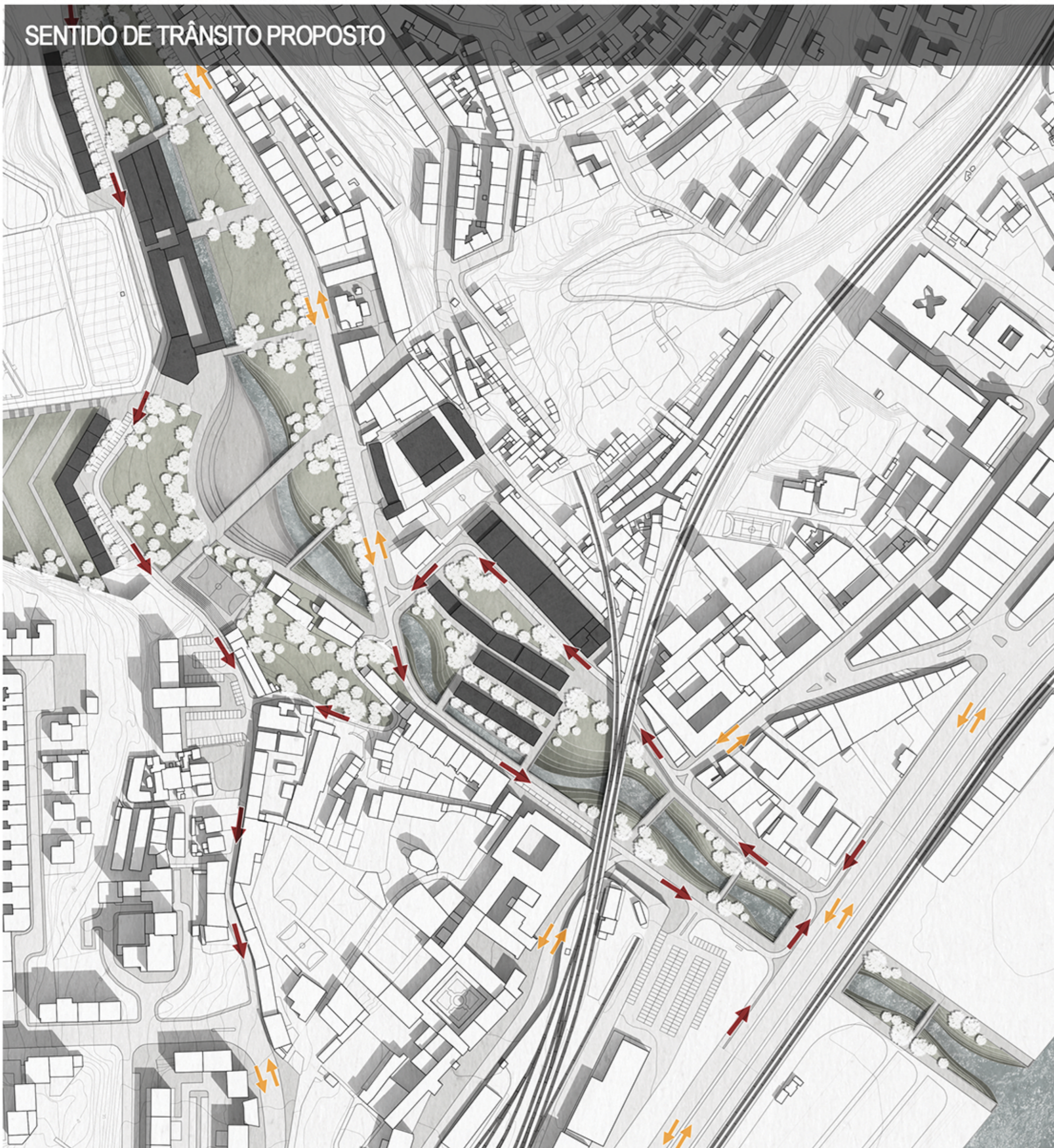

- SENTIDO ÚNICO
- DOIS SENTIDOS

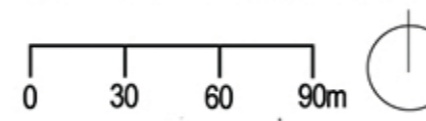

PERSPECTIVAS DE ESPAÇO PÚBLICO

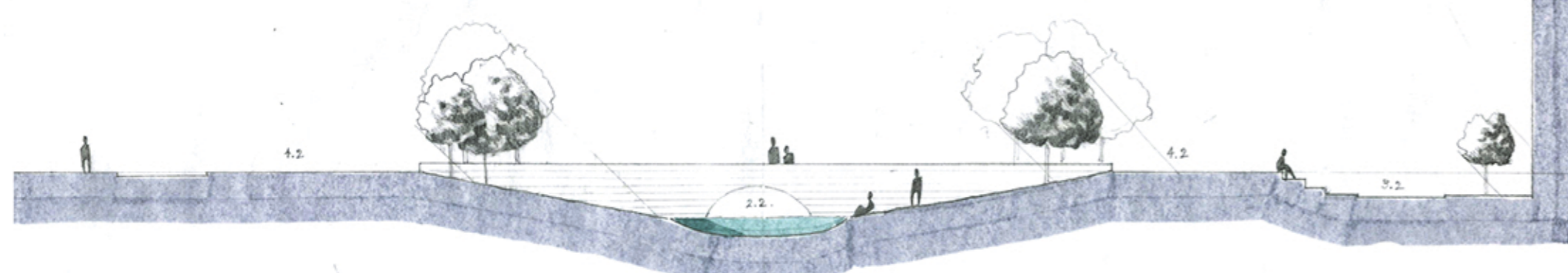
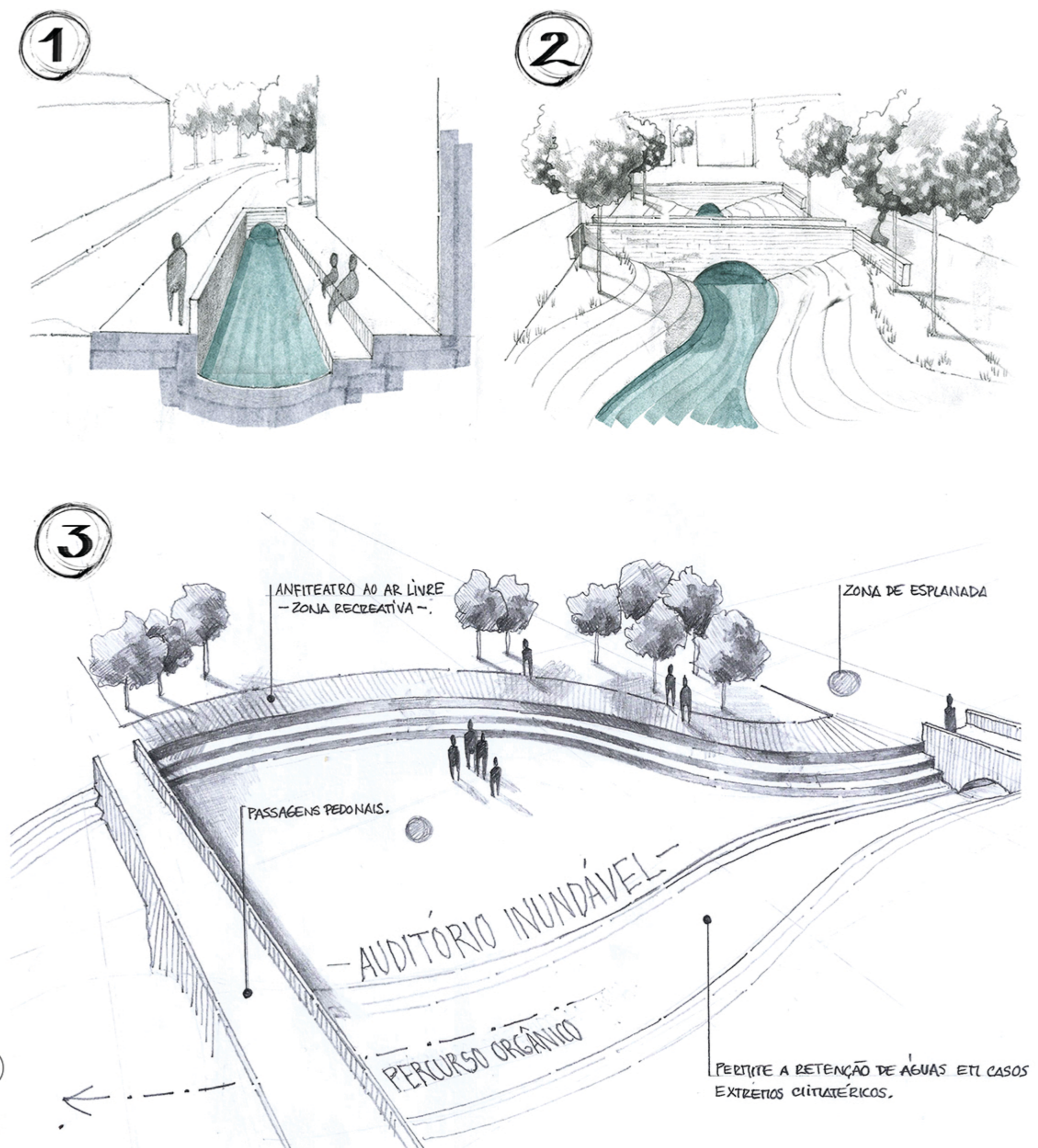



PROPOSTA URBANA DE BRAÇO DE PRATA | ESCALA 1:1000





REABILITAÇÃO

- RESTAURAÇÃO
- COMÉRCIO
- MISTOS 1 (COMÉRCIO, RESTAURAÇÃO, SERVIÇOS)
- EQUIPAMENTOS CULTURAIS
- EQUIPAMENTOS DESPORTIVOS
- RESIDÊNCIAS
- MISTOS 2 (COMÉRCIO, SERVIÇOS + HABITAÇÃO)
- ESCRITÓRIOS E/OU ATELIERS
- ESTACIONAMENTO
- PRAÇA DE ÁGUA INUNDÁVEL
- ESPAÇOS MULTIFUNCAIONAIS
- ESPAÇOS VERDES E/OU ARBORIZADOS
- ESPLANADA
- PERCURSO HISTÓRICO (LUMINAÇÃO DA LINHA DE COSTA DE 1911)

0 20 40 60m

0 20 40 60m

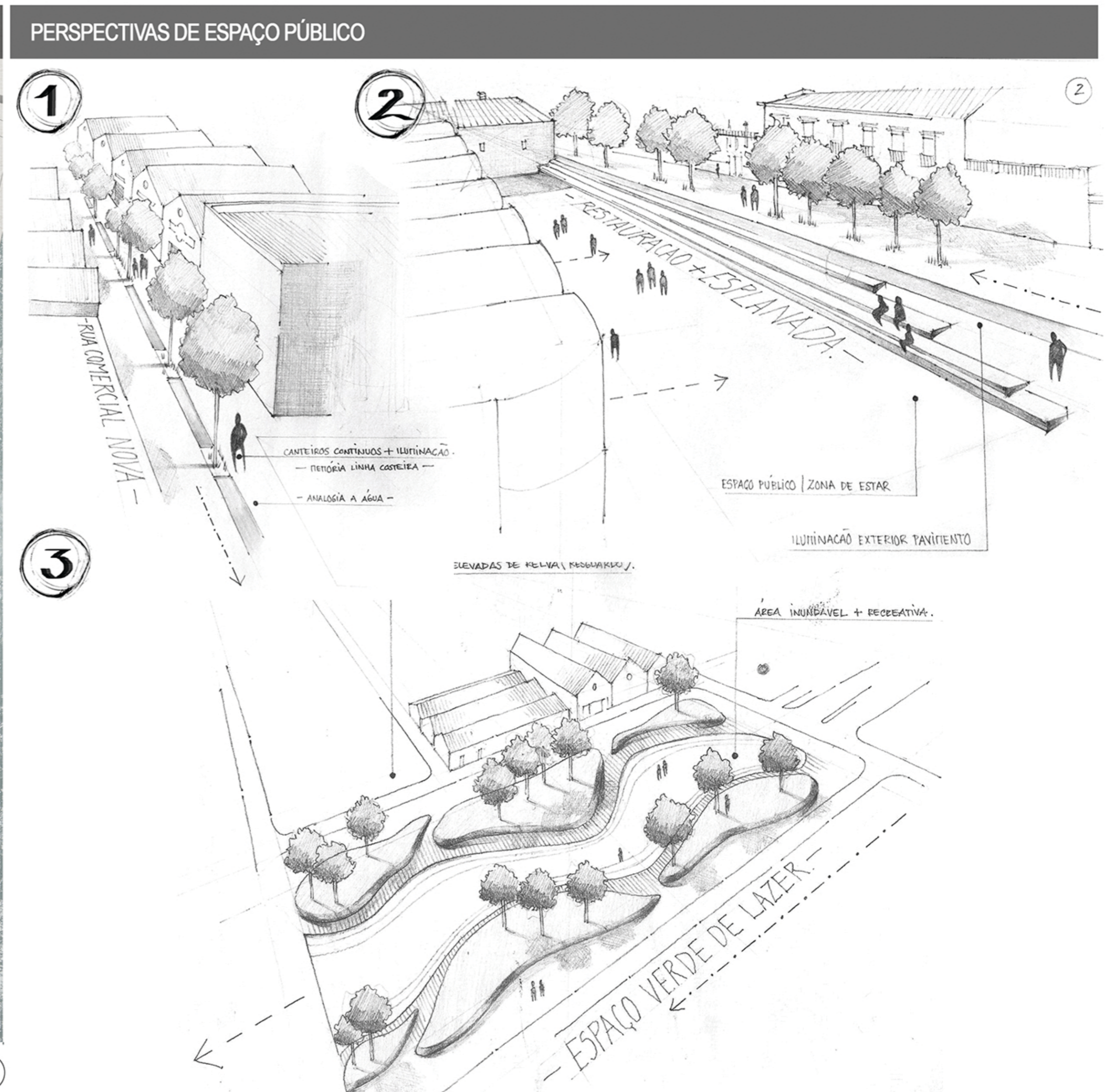

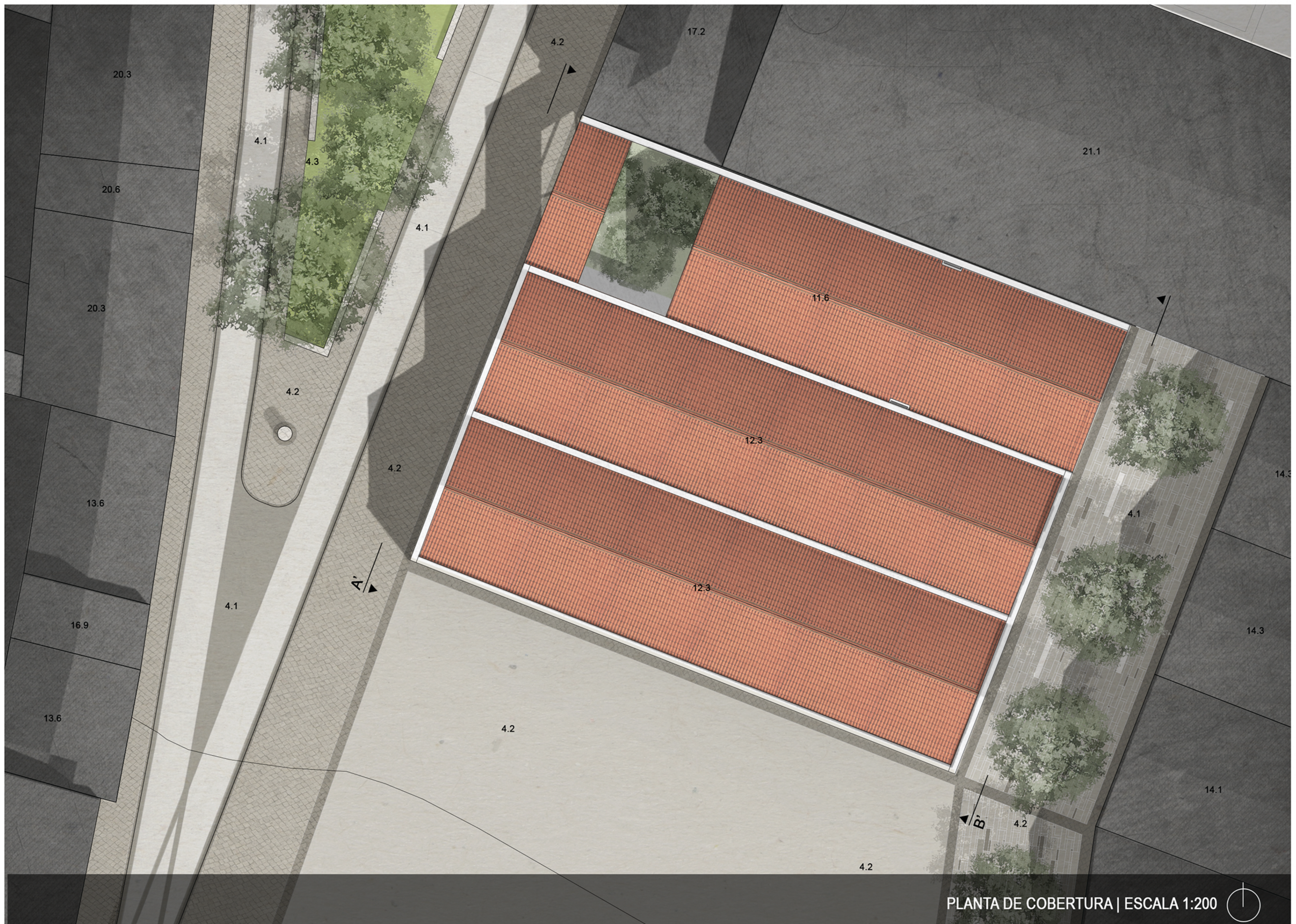



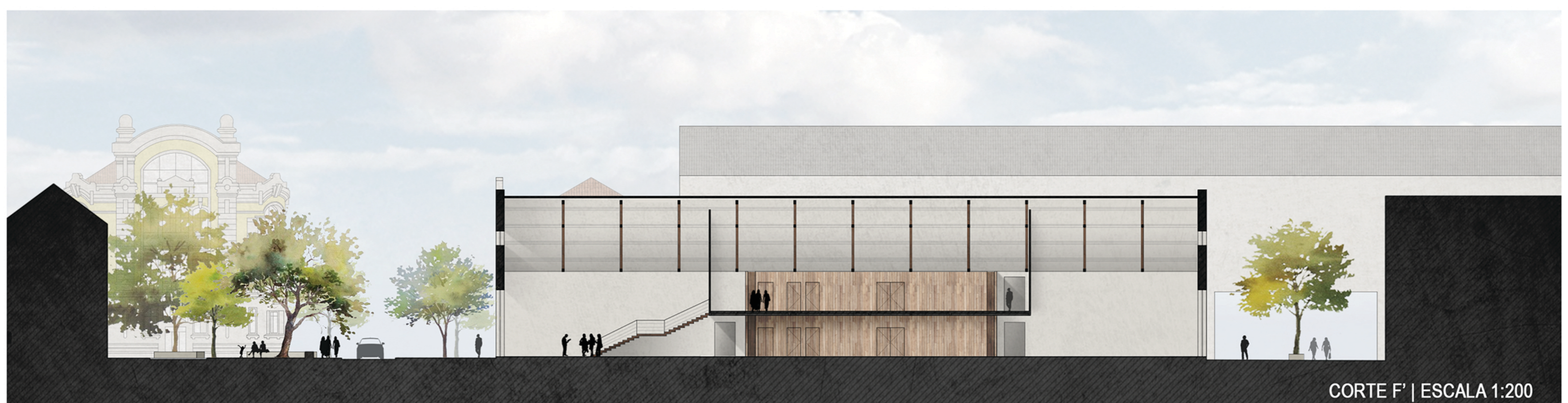

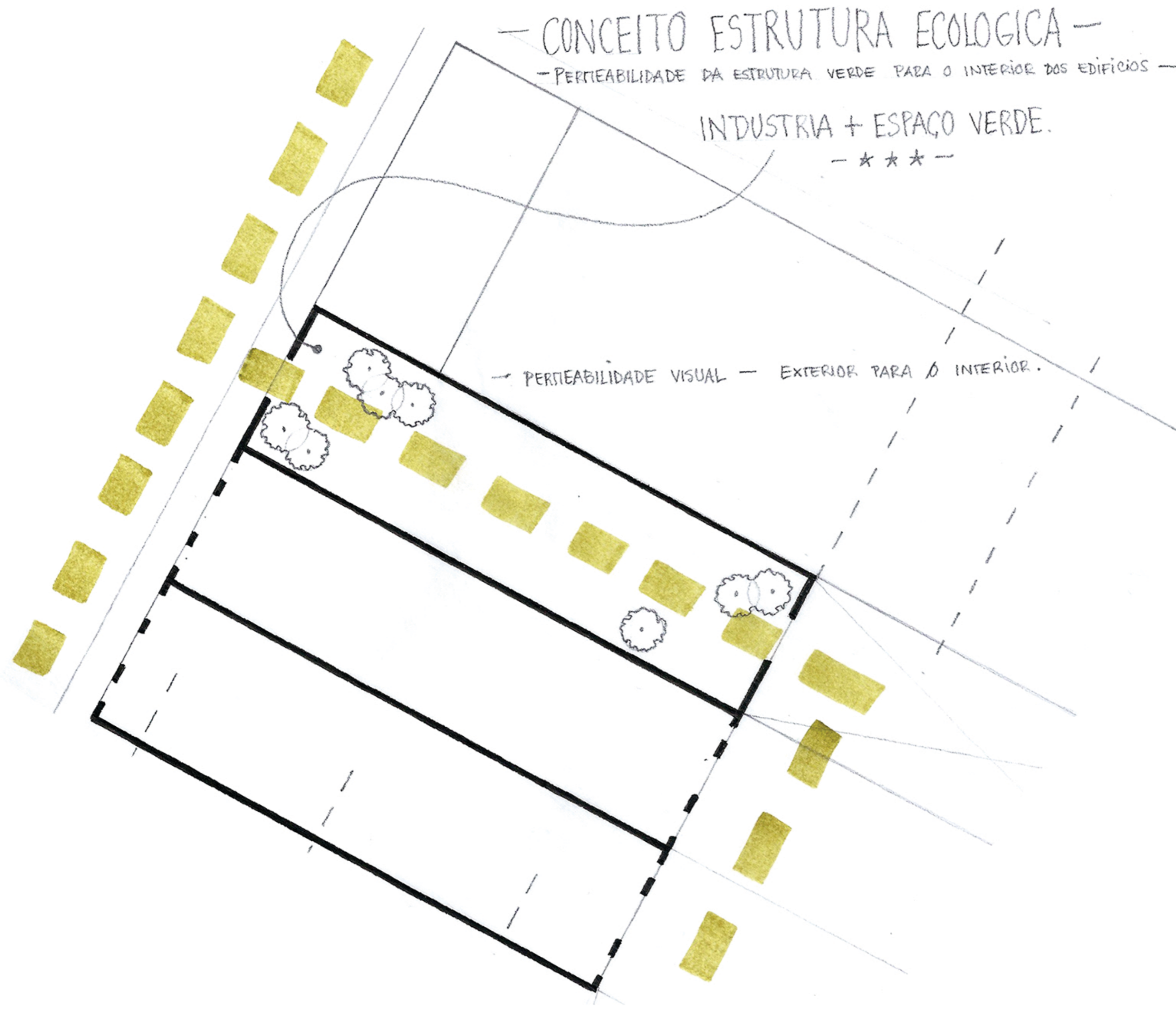

ESQUEMA DE AUTONOMIA EXISTENTE

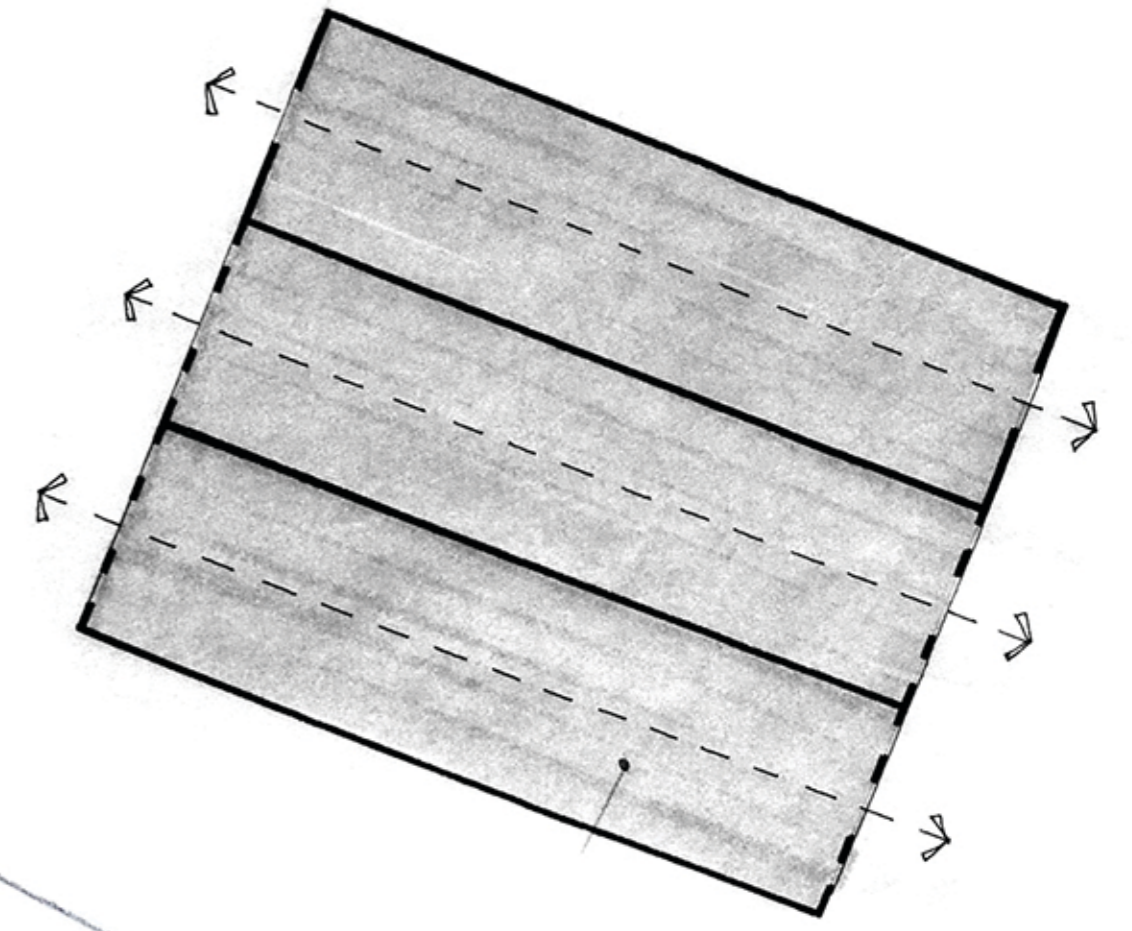

ESQUEMA DE AUTONOMIA PROPOSTO

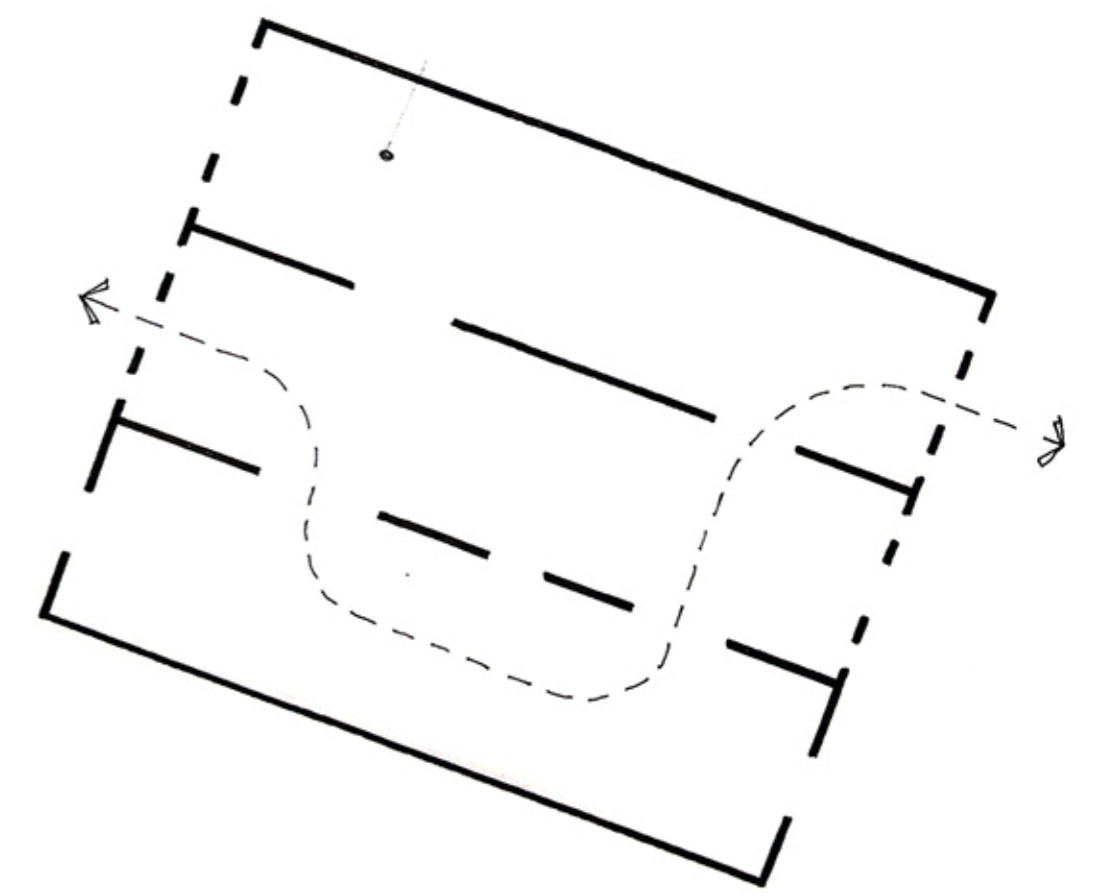

ESTUDOS DE COBERTURA

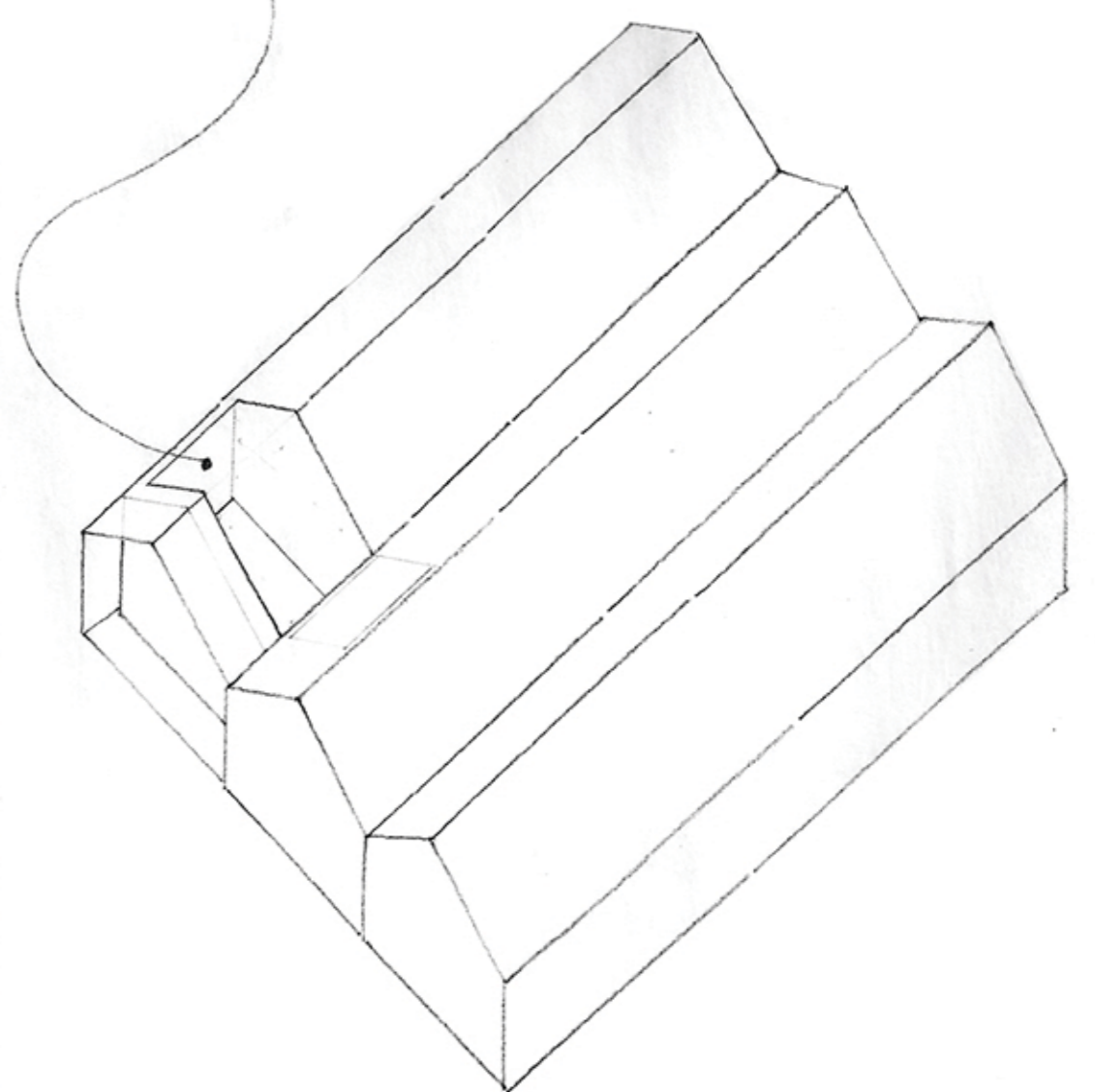
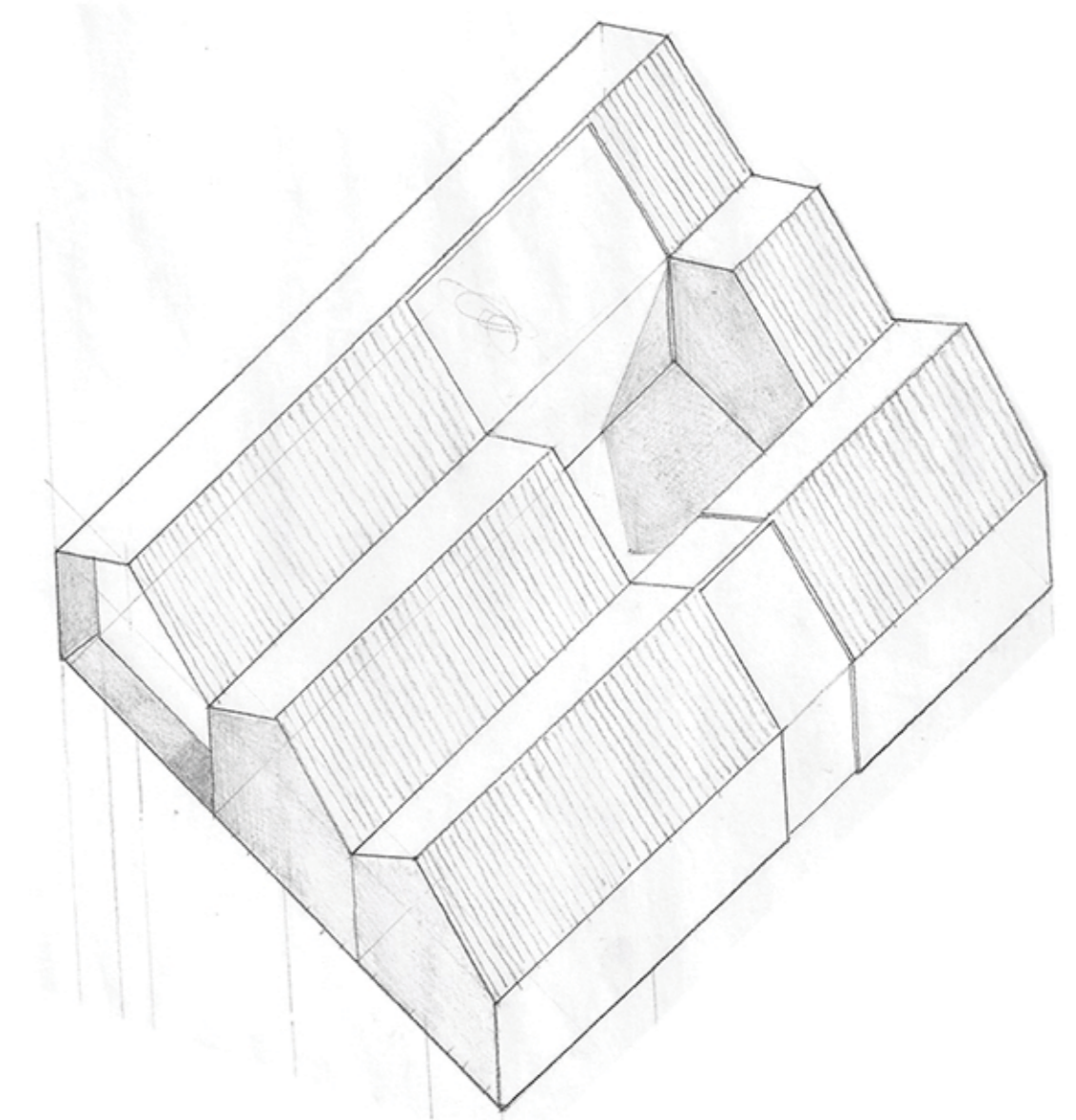
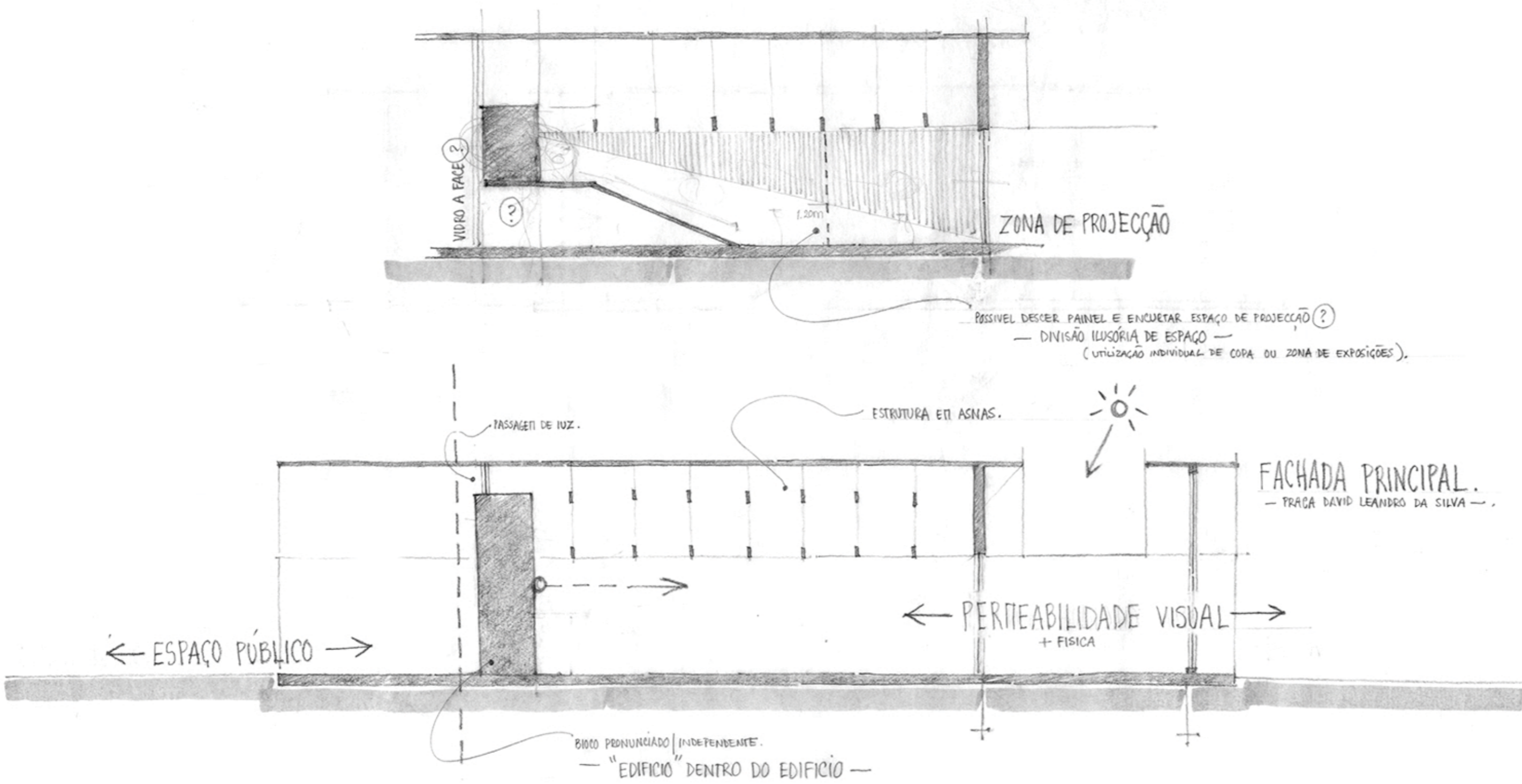

ARQUIPÉLAGO CONTEMPORARY ARTS CENTRE



MJH GALLERY ID TOWN

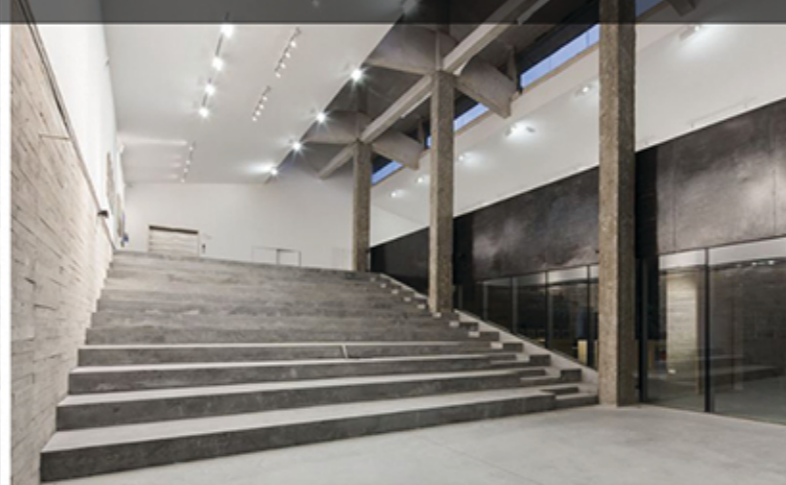

PRADA FOUNDATION ART MUSEUM



ENVIRONMENTAL INTERPRETATION CENTRE

