

**Pulsed Electric Fields for Moscatel Graúdo wine
production:
Investigation on wine sensory and physico-chemical characteristics**

Andrea Guanzioli

Dissertation to obtain a Master Degree in
Engenharia de Viticultura e Enologia

Supervisor: Maria Filipa Vinagre Marques da Silva Oliveira

Supervisor: Luis Manuel dos Santos Redondo

Jury:

President: Jorge Manuel Rodrigues Ricardo da Silva (PhD), Full Professor at Instituto Superior de Agronomia, Universidade de Lisboa.

Members: Maria Filipa Vinagre Marques da Silva Oliveira (PhD), Assistant Professor at Instituto Superior de Agronomia, Universidade de Lisboa;

Marcos Dória Nóbrega Teotónio Pereira (PhD), Energy Pulse Systems, Lda.

Acknowledgements

Foremost, I would like to express my gratitude to my thesis supervisors, Filipa Vinagre Silva, from Isa, and Luis Redondo, from Polo Tecnológico de Lisboa, for the continuous support in my study and research. For their availability, attention, patience, and knowledge through the last five months. Their guidance really helped me during research and writing of this thesis.

Besides my advisors, I would like to thank “PUREWINE Increasing quality and production capacity of European wine industry through an innovative Pulsed Electric Field-based process applied to vinification”, that made this project possible. Special thanks to LinDAA winery and his staff, and Mafalda Aguiar, for the analysis.

My sincere thanks to professor Jorge Ricardo da Silva, for his availability and the permission to use ISA laboratory. Also, thanks to the lab staff, especially to Joana Granja Soares and Joana Sales, to help me in the analysis, and Joel Santos. To the panellists, that made a part of the thesis possible.

Last, but not least, many thanks to my flatmates, Pino and Giacomo, for the support through the entire last year, and to all my friends, that shared with me this amazing experience, that I'll remember for the rest of my life.

To my family, that always sustain me in my choices, and made this dream come true.

Abstract

Pulsed electric field (PEF) processing of white grape (cv. Moscatel de Setúbal) before pressing for juice extraction, and before bottling for finished wine stabilization, was studied at pilot scale, to investigate the effect of the treatment on sensorial aspects and physico-chemical composition of wine. The application of PEF treatment before extraction increased yield of grape juice and wine colour assessed analytically with a spectrophotometer, although this change in colour was not perceived by the sensory panel. The PEF assisted extraction treatment did not affect the overall smell and taste of the wine, and content of phenolics. A slight increase in pH and turbidity, and a slight decrease in total acidity were observed. CIE L* colour coordinate was slightly lower (darker) in wine produced using PEF extraction. CIE a* and b* colour parameters increased in wine with pulsed electric fields applied in extraction.

The second PEF treatment applied for microbial stabilization of the wine did not influence pH, total acidity, but decreased total phenol contents and affected CIE colour parameters. Based on a statistic analysis of sensory results, panellists were not able to detect any difference between treated and non-treated wines, thus confirming the possibility to use PEF to improve the extraction and for microbial inactivation.

Keywords: PEF, extraction, stabilization, Moscatel de Setúbal, analysis.

Resumo

O tratamento do campo eléctrico pulsado (PEF) de uva branca (cv. Moscatel de Setúbal) antes da prensagem para extracção de sumo, e antes do engarrafamento para estabilização do vinho acabado, foi estudado à escala piloto, para investigar o efeito do tratamento nos aspectos sensoriais e na composição físico-química do vinho. A aplicação do tratamento PEF antes da extracção aumentou o rendimento do sumo de uva e a cor do vinho avaliada analiticamente com um espectrofotómetro, embora esta mudança de cor não tenha sido percebida pelo painel sensorial. O tratamento de extracção assistida por PEF não afectou o odor e sabor geral do vinho, nem o conteúdo de fenóis. Foi observado um ligeiro aumento do pH e turbidez, e uma ligeira diminuição da acidez total. A coordenada de cor CIE L* foi ligeiramente mais baixa (mais escura) no vinho produzido utilizando a extracção de PEF. Os parâmetros de cor CIE a* e b* aumentaram no vinho com campos eléctricos pulsantes aplicados na extracção.

O segundo tratamento de PEF aplicado para estabilização microbiana do vinho não influenciou o pH, acidez total, mas diminuiu o teor total de fenol e afectou os parâmetros de cor do CIE. Com base numa análise estatística dos resultados sensoriais, os entrevistados não foram capazes de detectar qualquer diferença entre vinhos tratados e não tratados, confirmando assim a possibilidade de utilizar PEF para melhorar a extracção e para inactivação microbiana.

- Palavras-chave: PEF, extracção, estabilização, Moscatel de Setúbal, análises

Resumo alargado

Durante as últimas décadas, muitas novas técnicas de processamento alimentar foram desenvolvidas em resposta à crescente procura de produtos alimentares seguros e de alta qualidade. Hoje em dia, os consumidores têm grandes expectativas quanto à qualidade sensorial, especialmente numa bebida complexa como o vinho. Atribuem também grande importância à utilização de tecnologias de produção alimentar amigas do ambiente.

Este trabalho discute os efeitos da aplicação de PEF no vinho, em duas etapas diferentes do processo de vinificação. Campos eléctricos pulsados foram aplicados a uma casta branca, Moscatel de Setúbal, antes da prensagem, para extracção de sumo e fenólicas, e antes do engarrafamento, para estabilização microbiana do vinho. Após os tratamentos, foram realizadas análises sensoriais e físico-químicas nas quatro amostras de vinho (CE, convencional extraído, PEF1, PEF extraído, CE+PEF2, convencional extraído e PEF estabilizado, PEF1+PEF2, PEF extraído e PEF estabilizado) para detectar qualquer efeito possível dos tratamentos com PEF nos parâmetros de qualidade do vinho. Em primeiro lugar, os vinhos extraídos convencional e PEF extraído foram comparados com a caracterização sensorial. O exame visual revelou uma cor amarela citrina, semelhante nas duas amostras, mesmo que tenha sido encontrada uma turvação ligeiramente superior na amostra de PEF1. Não foram detectadas diferenças olfactivas e gustativas, resultando em vinhos de boa qualidade, corpo leve, elevada acidez e, em suma, muito semelhantes. Em seguida, um teste triangular, para comparar três conjuntos diferentes de amostras: CE vs PEF1, CE vs CE+PEF2 e PEF1 vs PEF1+PEF2. 24 entrevistados não formados, mas habituados a beber vinho, foram solicitados a analisar a cor e o sabor das diferentes amostras. A partir dos resultados, os membros do painel não foram capazes de detectar diferenças entre as diferentes amostras comparadas. Após análise sensorial, foram analisados os seguintes parâmetros físico-químicos: rendimento, teor alcoólico, pH e acidez total, teor fenólico, turbidez, intensidade de cor (420nm) e valores CIELab. Os resultados da análise comparando o vinho CE e PEF1 evidenciaram um aumento no rendimento e absorção de sumo a 420nm. O conteúdo fenólico não foi afectado pelo tratamento, enquanto que se registou um aumento da turbidez. A EC tinha um valor L^* e a^* superior ao PEF1 da amostra, enquanto que o b^* era ligeiramente inferior. A aplicação de PEF para estabilização do vinho antes do engarrafamento não afectou as características sensoriais do vinho, uma vez que os entrevistados não foram capazes de reconhecer as diferentes amostras, nem influenciaram as características físico-químicas.

Table of contents

Acknowledgements.....	i
Abstract.....	ii
Resumo	iii
Resumo alargado	iv
Table of contents	v
List of figures.....	viii
List of tables	x
List of annexes	xi
1. Introduction	1
1.1 Moscatel of Setúbal or Moscatel Graúdo	3
1.2. Research objectives	4
2. Literature review	5
2.1. Pulsed Electric Fields (PEF) technology	5
2.1.1. Introduction	5
2.1.2. Mechanism of cell disruption by PEF	5
2.1.3 Fields of application.....	6
2.1.4 Advantages and disadvantages of PEF application	7
2.2. PEF equipment parts and costs	7
2.2.1. Pulse generator.....	8
2.2.2. Treatment chamber.....	8
2.2.3. Electrodes material, type and configuration	9
2.2.4 Equipment costs	11
2.3. PEF Process parameters	11
2.3.1 Electric field strength or intensity.....	11
2.3.2 Pulse wave shape and width.....	12
2.3.3 Pulse frequency	12
2.3.4 Treatment time.....	13
2.3.5 Energy density	13

2.4 PEF processing for wine production: effects on wine quality	14
2.4.1 Effect of electrical conductivity of the wine on process efficiency.....	14
2.4.2 Effect of PEF on yield of grape juice extraction	15
2.4.3 Effect of PEF on aroma of wine	16
2.4.3.1 Sensory perceptions of wine	16
2.4.3.2 Aroma compounds	17
2.4.4 Effect of PEF treatments on colour and physico-chemical characteristics of must and final wine.....	18
2.4.4.1 PEF extraction of must before pressing	18
2.4.4.2 PEF treatments of wine before bottling	21
2.5 Effect of PEF treatment of wine on microbial inactivation and potential SO₂ reduction	23
2.5.1 Application of PEF for decontamination of must.....	24
2.5.2 Application of PEF for wine decontamination after alcoholic fermentation	25
2.5.3 Application of PEF for wine decontamination after malolactic fermentation	26
2.5.4 Application of PEF for acceleration of yeast autolysis and aging on lees	26
2.5.5 Application of PEF for oak aged wine decontamination	27
3. Material and methods	28
3.1 Vinification of Moscatel table wine	28
3.2 Experimental design	29
3.3 PEF treatments	30
3.3.1 PEF aided juice extraction before pressing	30
3.3.2 PEF stabilization treatment before bottling.....	31
3.4 Sensory assessments	31
3.4.1 Wine sensory characterization	31
3.4.2 Consumer triangular test for colour and overall flavour	31
3.5 Physico-chemical analysis	32
3.5.1 Pressing yield.....	32
3.5.2 Alcohol content.....	32
3.5.3 pH and total acidity	33
3.5.4 TPI (total polyphenol index)	33
3.5.5 Flavonoids and non-flavonoids.....	33
3.5.6 Turbidity	34
3.5.7 Colour intensity and CIELab analysis.....	34
3.5.8 Statistical analysis	35

4. Results and discussion	36
4.1 Sensory characterization of wines	36
4.2 Triangular test	37
4.2.1 Colour and taste evaluation of wines from CE and PEF treated must before pressing	37
4.2.1.1 Colour evaluation.....	37
4.2.1.2 Taste evaluation.....	38
4.2.2 Colour and taste evaluation of conventionally extracted wine (CE) and CE submitted to PEF before bottling (PEF2).....	38
4.2.2.1 Colour evaluation (CE vs CE+PEF2).....	39
4.2.2.2 Taste evaluation (CE vs CE+PEF2)	39
4.2.3 Colour and taste evaluation of wines from PEF extracted must (PEF1) and PEF treated before botting (PEF1+PEF2)	40
4.2.3.1 Colour evaluation (PEF1 vs PEF1+PEF2)	40
4.2.3.2 Taste evaluation (PEF1 vs PEF1+PEF2)	41
4.3 Physico-chemical properties of the wine and pressing yield of grape juice	41
4.3.1 Pressing yield.....	42
4.3.2 Alcohol content	42
4.3.3 pH and total acidity	42
4.3.4 Total phenols, flavonoids and non-flavonoids	43
4.3.5 Turbidity.....	45
4.3.6 Colour intensity and CIELab colour parameters	45
5. Conclusions	48
List of references	49
Appendix	60
Sensorial analysis results.....	63
Physico-chemical analysis results.....	64

List of figures

Figure 1.1 Main operations involved in table white wine vinification

Figure 1.2 Moscatel-gràudo shoot aspect (vinetowinecircle.com)

Figure 1.3 Moscatel-gràudo grape and leaf morphologies (www.clubevinhosportugueses.pt)

Figure 1.4 Moscatel-gràudo production area (vinetowinecircle.com)

Figure 2.1 Different outcomes of PEF application (Toepfl, 2006)

Figure 2.2. A typical PEF unit used in food processing (Nowosad et al., 2020)

Figure 2.3 Batch and continuous chambers scheme (Naliyadhara et al., 2022)

Figure 2.4 Common pulse-waveforms in PEF application (Kumar et al., 2015)

Figure 2.5 Microscopic photos of peel tissue of Lemberger wine grapes before and after electroporation (Ozturk & Anli, 2017)

Figure 2.6 Juice yield Y (%) vs. expression time t (s) in the pressing experiments without PEF-treatment (■), with PEF pre-treatment (▼) and intermediate PEF treatment (◇) for Muscadelle, Sauvignon and Semillon grapes (Praporscic I. et al., 2006)

Figure 2.7 Image of Garnacha must after 1h of maceration with untreated and PEF-treated (1-7kV/cm) grapes (Ozturk et Anli, 2017)

Figure 2.8 Evolution of color intensity (CI) – a, total anthocyanin content (TAC) - b, total polyphenol index (TPI) - c, along fermentation–maceration time during the first 7 days of vinification of untreated Garnacha grapes (empty bars) and grapes treated by PEF (full bars). Figure a also shows evolution of must density during fermentation. Error bars correspond to standard deviation of the mean (Luengo et al., 2013)

Figure 2.9 Share of red component *a in colour of control, 3.3 and 5 kV/cm PEF treated wines Ilona, G., Ewa, K., & Andrzej, C. (2018)

Figure 2.10 Steps of winemaking in which pulsed electric fields have potential application for microbial control and decontamination (Delso et al., 2021)

Figure 2.11 Survival curves of the studied microorganisms at different electric field strengths: 16 kV/cm (●), 22 kV/cm (▼), 25 kV/cm (Δ), 31 kV/cm (■). Treatment conditions: must, 1.97 ± 0.23 mS/cm (Puertolas et al., 2009)

Figure 2.12 Inactivation of *E. coli* (A), *Candida lipolytica* (B), *H. anomala* (C), *Lactobacillus delbruekii* (D) and *Saccharomyces cerevisiae* (E) by pulsed electric fields as a function of electric field strenght and treatment temperature (Abca & Evrendilek, 2014)

Figure 2.13 Mechanism of pulsed electric field triggering yeast autolysis (Delso et al., 2022)

Figure 3.1 Experimental design of the pulsed electric fields (PEF) treatments applied on must and finished wine

Figure 3.2 Co-linear PEF treatment chamber used before pressing with vertical configuration.

Figure 3.3 Photographs of PEF treatment chamber used for microbial inactivation, before bottling, for wine stabilization.

Figure 4.1. Percentage of panellists with right choice who classified the degree of colour difference between the two samples (CE and PEF) as slight, none and moderate

Figure 4.2 Total phenols content of different wine samples. CE conventional extraction, PEF1 PEF extraction, CE+PEF2 conventional extraction + PEF stabilization treatment, PEF1+PEF2 PEF extraction + PEF stabilization treatments (values are sample averages, and error bars are standard deviations; different letters indicate significantly different values according Tukey test)

Figure 4.3 Turbidity level (NTU) of different wine samples. CE conventional extraction, PEF1 PEF extraction, CE+PEF2 conventional extraction + PEF stabilization treatment, PEF1+PEF2 PEF extraction + PEF stabilization treatments (values are sample averages, and error bars are standard deviations; different letters indicate significantly different values according Tukey test)

Figure 4.4 Absorbance values (abs) of different samples. CE, conventional extraction PEF1, PEF extraction CE+PEF2, conventional extraction + PEF stabilization treatment - PEF1+PEF2, PEF extraction + PEF stabilization treatment. (values are averages of triplicates, and error bars are standard deviations; means with different letters are significantly different according to Tukey test)

Figure 4.5 L* CIE value of different wine samples: CE conventional extraction, PEF1 PEF extraction, CE+PEF2 conventional extraction + PEF stabilization treatment, PEF1+PEF22 PEF extraction + PEF stabilization treatments (values are averages of triplicates, and error bars are standard deviations; means with different letters are significantly different according to Tukey test).

Figure 4.6 a* CIE colour of different wine samples: CE conventional extraction, PEF1 PEF extraction, CE+PEF2 conventional extraction + PEF stabilization treatment, PEF1+PEF22 PEF extraction + PEF stabilization treatments (values are averages of triplicates, and error bars are standard deviations; means with different letters are significantly different according to Tukey test).

Figure 4.7 b* CIE colour of different wine samples: CE conventional extraction, PEF1 PEF extraction, CE+PEF2 conventional extraction + PEF stabilization treatment, PEF1+PEF22 PEF extraction + PEF stabilization treatments (values are averages of triplicates, and error bars are standard deviations; means with different letters are significantly different according to Tukey test).

List of tables

Table 2.1 Common characteristics of different electrode configurations (Arshad et al., 2020)

Table 2.2. Wine colour (Abs 420nm), TPI and POM-test value on control (untreated) and PEF-processed (PEF 11 and PEF 22) wines, fifty days after AF. (Comuzzo et al., 2018)

Table 3.1 Date of harvest and weight of grapes used as "control" (conventionally extracted) and "PEF1" treatment (pulsed electric fields aided extraction)

Table 3.2 Physico-chemical parameters of "CE" and "PEF1" treatment

Table 3.3 Additions in CE (conventional extraction) and pulsed PEF (electric fields extracted) samples.

Table 3.4. Correspondence between turbidity measurement (NTU) and appearance (adapted by Ribereau-Gayon et al., 2006)

Table 4.1 Results of triangle test, to compare overall colour of treated (PEF extraction) and non-treated wine (conventional extraction). The expected number of right answers is 8 ($n/3$) and 16 ($2n/3$) for wrong ones.

Table 4.2 Results of triangle test, to compare overall smell and taste (flavour) of treated (PEF extraction) and non-treated wine (conventional extraction).

Table 4.3 Results of triangle test, to compare the overall colour between non-treated (CE) wine PEF stabilized wine (CE+PEF2).

Table 4.4 Results of triangle test, to compare verify the colour differences between non-treated (CE) wine and PEF stabilized wine (CE+PEF2).

Table 4.5 Results of triangle test, to compare colour of wine from PEF extraction before pressing (PEF1) and the same wine PEF treated before bottling (PEF1+PEF2).

Table 4.6 Results of triangle test, to verify the colour differences between wine treated just before pressing (PEF1) and wine treated twice, before pressing and before bottling (PEF1+PEF2) wine.

Table 4.7 Yield difference between PEF treated (230921_MO_PEF) and non treated (230921_MO_C) samples

Table 4.8 Alcoholic strength (v/v) of different wine samples. CE conventional extraction, PEF1 PEF extraction, CE+PEF2 conventional extraction + PEF stabilization treatment, PEF1+PEF2 PEF extraction and stabilization treatments (Results are means \pm Standard Deviations of triplicates, different letters indicate significantly different values according Tukey test)

Table 4.9 pH values of the different samples. CE conventional extraction, PEF1 PEF extraction, CE+PEF2 conventional extraction + PEF stabilization treatment, PEF1+PEF2 PEF extraction and stabilization treatments (Results are means \pm Standard Deviations of triplicates, different letters indicate significantly different values according Tukey test)

Table 4.10 Total acidity results (g/L tartaric acid) of different samples. CE, conventional extraction PEF1, PEF extraction CE+PEF2, conventional extraction + PEF stabilization treatment - PEF1+PEF2, PEF extraction + PEF stabilization treatment. (Results are means \pm Standard Deviations of triplicates, for each column different letters indicate significantly different values according Tukey test)

Table 4.11 Total phenols, non-flavonoids and flavonoids contents of different wine samples. CE conventional extraction, PEF1 PEF extraction, CE+PEF2 conventional extraction + PEF stabilization treatment, PEF1+PEF2 PEF extraction and stabilization treatments

List of annexes

1. “Ficha de prova” for trinagular test
2. Triangular tests results
3. Physico-chemical analysis results:
 - Alcoholic content
 - pH
 - Total acidity
 - Total phenols
 - Flavonoids
 - Non-flavonoids
 - Turbidity
 - Colour (420nm)
 - CIELab

1. Introduction

During the last decades, new techniques for food processing are being introduced, in response of consumers demand for products with higher quality and safety. With the technological progress, the introduction of new techniques can increase the food and beverage industries competitiveness and sustainability, the productivity, and the products quality (Milani and Silva, 2022). The use of pulsed electric fields (PEF) in food production was introduced with the aim to produce foods with high nutritional value, decreasing the risk of microbial spoilage, while trying to respect the environment (Evans and Cox 2006). PEF is a non-thermal technology, able to generate irreversible electroporation in the cell membranes by means of an electric field, resulting in a deactivation of spoilage microorganisms while preserving the thermolabile components and organoleptic properties of the beverages. PEF only works with conductive liquids, so that the electric fields can reach and electroporate the target cells. As the mechanism of cell inactivation is not based on heat, the wine stabilization treatment temperature is reduced. In the wine sector, electroporation of grape skin cells is a very important application for PEF to improve the efficiency of juice extraction. PEF only works with conductive liquids, so that the electric fields reach and electroporate the cells. This technology has several applications, that space from biomedical to food production.

Nowadays, it is a widely acknowledged non-thermal option to the thermal pasteurization for liquid foods and, in some cases, can be used to improve the extraction of compounds that need time and/or specific conditions to be extracted. These principles can be applied in the winemaking process, at different stages.

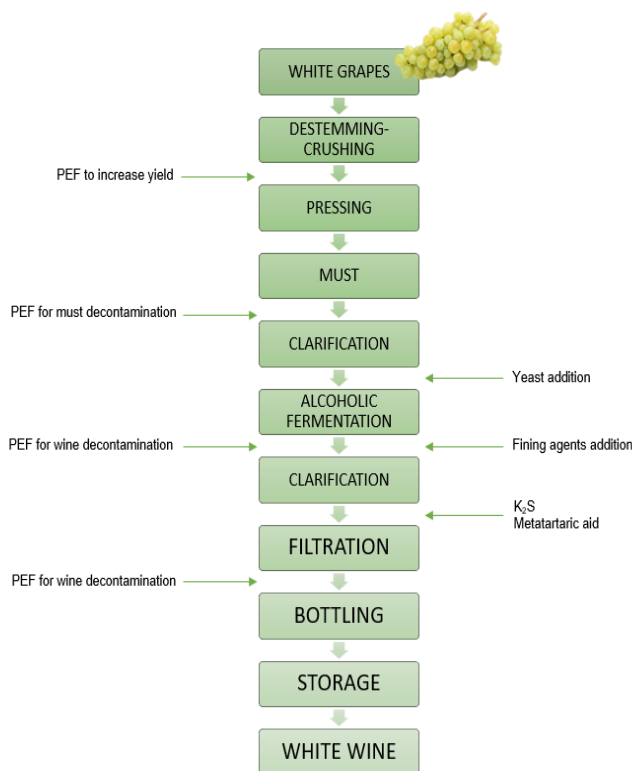

Figure 1.1 Main operations involved in table white

The Figure 1.1 resumes the process for the production of a typical white dry wine. This kind of wine usually derives from white varieties grapes. The first pre-fermentative operations to be carried out, optional, are the destemming and crushing of grapes. The first allows the removal of stalks from the grapes, when manual harvest is adopted, even if the presence of stalks permits a better drainage and a lower content of thermolabile proteins, while the second is mainly used to improve the press capacity and shorten the process. These practices can be avoided if the press capacity allows it. Then, grapes are pressed to extract the juice and other chemical compounds from the solid parts. This is a crucial part, that aim to limit juice loss and clarify it, while extracting constituents from the skins like terpenes, fruity aroma precursors and polyphenols, limiting the presence of bitter and herbaceous flavours from stalks and skins solid parts and the contact with air, responsible for phenols oxidation and the browning of must. After pressing, wine is sent to a vat where it rests for a time frame necessary for the separation of must and lees, that will deposit on the bottom of the vat, or clarified using different technologies. The quantity of lees and the rate of precipitation will depend on the grape variety, its sanitary state and how grapes have been treated. This process, called "clarification", can be carried out statically, with a natural sedimentation or with the use of pectinase enzymes, or mechanically, by centrifugation, filtration, floatation and so on. Then, wine is racked to another vat where sugar and acidity corrections can be achieved, and, if necessary, treated with bentonite to obtain an optimal turbidity value for the wine to be ready for the alcoholic fermentation. AF can be spontaneous, with autochthonous yeasts deriving from grapes or cellar environment, or induced, by addition of ADY, allowing to use strains with desired characteristics. AF usually lasts about a week-ten days, with daily analysis of temperature and density, reaching 0.994-0.993 at the end of the process, with a reducing sugars amount below 2g/L. Malolactic fermentation is usually not realized to preserve acidity and freshness, very important parameters for this style of wine. Later on, wine can be kept on his lees or racked and stored, clarified-filtered and bottled, with SO₂ addition to avoid microorganism spoilages and oxidation. (*Ribèreau-Gayon et al, 2017*).

For red wines, PEF can be used to improve the efficiency of maceration step and reduce the time required for maceration, increasing the extraction of polyphenols and other important compounds from the grape skins. Overall PEF can improve wine colour and chemical composition of wine. As evidenced in a study conducted in 2020, the wine treated with pulsed electric fields led to a higher colour and total phenolic index (TPI) when compared to the control sample, evidencing a higher amount of tannins and total phenols. Also, the modifications were stable after 12 months, underlining the effectiveness of the treatment (*Comuzzo et al. 2020*). For white wines, the use of PEF treatment allowed to obtain a wine with higher amount of varietal aroma precursors, without an excessive colour evolution and phenolic compound extraction (*Comuzzo et al. 2018*).

PEF electroporates the grape cell membranes, increasing the yield and efficiency of grape juice extraction. Overall, this equipment allows to speed up the pressing process.

One other important PEF benefit and application in wine production is related to the capability of pulsed electric fields to inactivate microorganisms responsible for wine spoilage. This has commercial interest as it may help to reduce or even replace the use of SO₂ for wine stabilization, prior bottling, enhancing wine quality by reducing wine spoilage risks and allergies in wine consumers, which are frequently caused by SO₂ (*van Wyk and Silva, 2019; Silva and van Wyk, 2021; Maza et al. 2022*). In fact, according to *Ribereau Gayon et al. (2017)*, typical SO₂ intoxication symptoms are nausea, vomiting and gastric irritation and, more recently, allergic reactions were evidenced as well. That's why is important to reduce the use of these compound in the winemaking procedure.

1.1 Moscatel of Setúbal or Moscatel Graúdo

In our experiments table white wine was produced from Moscatel of Setúbal or Moscatel Graúdo Portuguese grape variety (*Figures 1.2 and 1.3*). International synonyms of this cast include Moscatel de Alexandria, and in Spain Moscatel de Jesus Muscat, Moscatel, Moscatell, Aggliko, Moscatel Gordo, Moscatel Branco, among others denominations internationally recognised (http://www.vinetowinecircle.com/en/castas_post/moscatel-de-alexandria-moscatel-graudo-branco-2/).



Figure 1.2 Moscatel-Graúdo shoot aspect (vinetowinecircle.com)



Figure 1.3 Moscatel-Graúdo grape and leaf morphologies (www.clubevinhosportugueses.pt)

This variety was possibly originated from Egypt. Later on, the variety was brought to the Iberian Peninsula by the Phoenicians, who used to produce wine from it. Nowadays, the variety is mainly cultivated in Spain and, in Portugal (around 700 ha under Moscatel cultivation), in Setúbal peninsula, where it is mainly used to produce Moscatel de Setúbal, a dessert fortified wine produced with addition of grape brandy, aged in oak for a minimum of 18 months.



Figure 1.4 Moscatel-Graúdo production area (vinetowinecircle.com)

The variety presents medium size leaves, rounded, with three lobos, the bunch is large, conical with wings and long peduncle, while berries are large, ovate, yellowish green (*Figure 1.4*). Skin has medium thickness and firm flesh. The growth cycle is quite slow, and the plant do not own a high vigour of shoots and low to medium bud fertility. It is usually trained with short pruning, using cordons, and requires high temperatures and level of solar radiations. From an oenological point of view, this variety is usually used to produce dessert and sweet wines, as well as for table wines. It presents a high level of terpenoid compounds, that confer high aromaticity to the final product. Wines can be aged, especially sweet ones, and can be generally described as strong straw coloured, with intense muscat aroma, very persistent.

1.2. Research objectives

Pulsed electric fields treatment is an emerging process for non-thermal wine microbial stabilization, and it was demonstrated to be useful in different stages of the winemaking process. Being a continuous process, there is a great potential for application of this technology to stabilize beverages, as wines (*Milani and Silva, 2022*). Studies using this technique with wine have been carried out in the last years, to investigate the effectiveness of the treatment with regards to the chemical and sensory characteristics of the wine, and its shelf-life along time. However, as reported by Arshad et al. 2020, not many research and applications at industrial scale have been carried out, as opposed to the bench-scale systems. There is a need to conduct future research towards continuous processing models to meet industrial requirements and ensure commercial acceptance, as it requires substantial funding and research collaboration among various research groups to support this research scope.

This thesis project aims to study the effects of the application of PEF technology in the production and stabilization of a Portuguese mono-variety table white wine made from “Moscatel de Setúbal (also known as Moscatel Graúdo). PEF treatment will be applied during grape crushing, before the pressing, to increase the yield, and prior bottling, to inactivate microorganisms. The specific objectives of this research work were:

- I. to study the effect of PEF at pilot scale winery, implemented in a commercial winery for extraction of grape juice and stabilization of wine
- II. to assess the mechanical, sensorial and physico-chemical differences between conventional juice extraction and PEF juice extraction carried out before pressing at the beginning of the production
- III. to assess the sensorial and physico-chemical differences between conventional wine and wine\ stabilized with PEF, applied before bottling at the end of the production

2. Literature review

2.1. Pulsed Electric Fields (PEF) technology

2.1.1. Introduction

Pulsed Electric Field (PEF) technology is a non-thermal technique substantially used in several fields with different applications, from food to environment and medical sector. PEF consists in the application of periodic high intensity, short length electric pulses to cell suspension through an electric field, creating unrecoverable pores in the cell membrane, increasing the passage of liquids and particles (Naliyadhara *et al.* 2022). Firstly introduced in the USA in the twenties, the process was known as “electropure process”, mainly used for the milk process of pasteurization (Palaniappan *et al.* 1990), becoming more and more popular in the following decades. The first studies regarding this technology were carried out in the sixties, by Sale and Hamilton, regarding the application of PEF for bacterial inactivation. These studies evidenced that the kill rate of a population was determined by the pulses number and pulses length product, as well as the field strength in the suspension, excluding the increase of temperature (Sale & Hamilton, 1967). As heat is an undesirable secondary effect, it is considered a non-thermal technology and produces beverages with higher nutritional value, and better sensory characteristics (Van Wyk *et al.* 2018). Later, other studies have been carried evidencing that PEF technology and application, to increase the efficiency rate and applicability.

2.1.2. Mechanism of cell disruption by PEF

Basically, PEF treatment consists in the application of a high intensity electric field to the product to be treated. As reported by Zimmermann *et al.* (1974), cell's membrane separates the cell from the outer environment, and this membrane contains dielectric compounds, that confer it a charge. When exposed to an electric field, the dielectric compounds acquire a charge and move in the opposite direction. This movement of oppositely charged ions at both sides of cell wall leads to the formation of a trans-membrane potential, that generates an electro-chemical stress inside the cell membrane (Arshad *et al.*, 2020, Tylewicz, 2020) (Figure 2. 1). Transmembrane potential 'U_m' in (V) generated by an external electric field for a spherical cell can be calculated as follows (Equation 2. 1)

$$U_m = 1.5 r E \cos \theta \quad (2.1)$$

Where 'r' is radius of the target cell (µm), required electric field strength 'E' (kV/cm⁻¹), and the orientation 'θ' (degree) of the target cell in the electric field. PEF food processing is effective when the applied electric field induces a voltage across the cell's membrane 'U_m' which exceeds the critical transmembrane potential 'V_c' (0.5–1 V). The required critical potential and energy is dependent upon the sample food and processing technique.

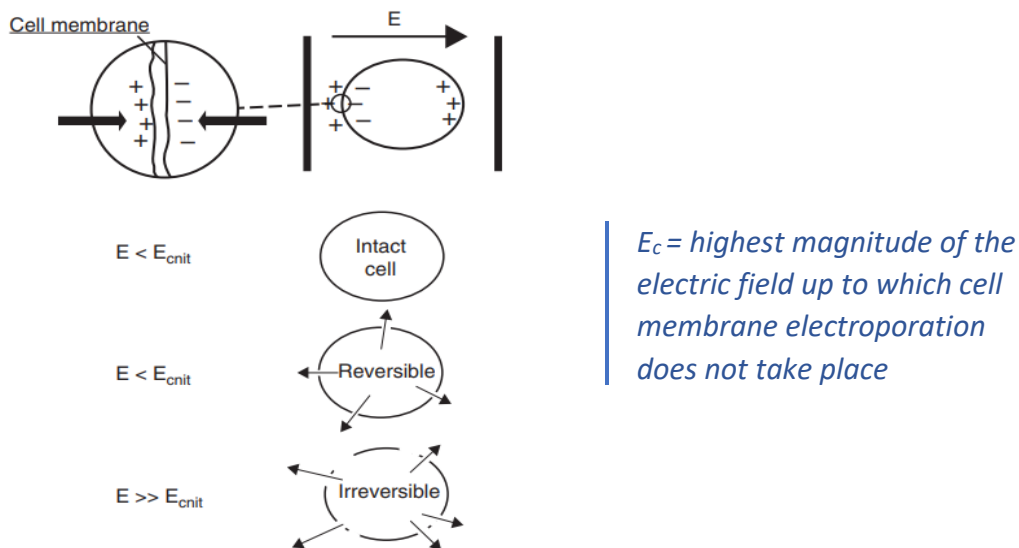

Figure 2.1 Different outcomes of PEF application (Toepfl, 2006)

As shown in the picture (Figure 2. 1), when an electric field is applied to a cell, three situations can verify, resumed in “dielectric rupture theory” as:

- Electric field applied is weak, and cell remains intact
- Electric field applied is identical or little higher of E_c , generating pores into cell membrane, but cell is able to restore when the applied field is removed
- Electric field has a sufficient power to irreversibly break cell wall

So, for this purpose, an external electric field applied above E_c threshold has to be applied. E_c varies in function of the cell size and shape, electrical conductivity of the fluid and the orientation of cell wall towards the electric field (Tylewicz, 2020).

2.1.3 Fields of application

Although pulsed electric fields can be applied in several sectors, literature evinced that the main applications of PEF are related to the medical area, for cancer treatment, and widely applied in beverages production and processing. Niu et al. (2020), published a review with the achievements of this technology not only to inactivate microorganisms, but also to increase the efficiency of the extraction of active constituents, yet to modify biomacromolecules. Also, it allows to enhance chemical reactions and accelerate the aging of fermented foods, related to bio-membranes permeabilization, electrochemical and electrolytic reactions, molecules polarization and reduction of activation energy of chemical reactions. PEF can be useful to improve the extraction of natural compounds (Sun et al. 2019), and in recent years, a growing interest in microstructure and functional properties modification of bio-macromolecules, in order to meet food industry needs (Giteru et al., 2018). PEF is very versatile. High voltage pulses can be used for liquid and semi-solid liquids e.g. soups, eggs and fruit juices, with several different applications (Qin et al., 1995), and with solid products, mainly in potato processing industry (Faridnia et

al., 2015). In this case, the effect of PEF is a modification of the integrity of tissues, reducing acrylamide content in fried potatoes, a toxic compound (*Genovese et al., 2019*). In the last decades, this technology has also been applied in the winemaking process, at different productive levels, that will be discussed later, with positive results.

2.1.4 Advantages and disadvantages of PEF application

PEF is a method where short pulsed electric fields are applied. Depending on the food characteristics and the effect to be obtained, the process conditions, deeply discussed later, can be suitably modified. For instance, an electric field that ranges 0.1–1 kV/cm, causes reversible poration of plant cells, 0.5–3 kV/cm, irreversible poration of animal and plant cells, and 15–40 kV/cm leads to death of microbial cells (*Tsong 1996*). Therefore, the equipment should allow to be set up differently, according to the needs. Lately, one of the main fields of application, as alternative energy-saving process, is food processing in a non-thermal method (*Soliva-Fortuny et al., 2009*). Yet, it should be mentioned that the electric field applied could generate heat, that could lead to a deterioration of the processed food, if a cooling system is not equipped to properly cool the product before and/or after the treatment. On the other hand, the combination of PEF and higher temperature has resulted more effective as inactivation effect (*Jaeger et al., 2010*). Despite this technology has been quite deeply investigated, most of the research has been performed at laboratory scale, with just a low number of equipment used at industrial scale. A treatment on large scale could give different results. The technology is generally considered safe for human's health. In fact, no harmful reactions have been reported (*Frewer et al. 2011*). However, some constituents are generally released into the food sample due to electrodes corrosion e.g. Fe, Cr, Ni, Mn (*Roodenburg et al. 2005*). Different kind of materials have been used to try to overcome this issue, discussed in section "Electrode materials, types and configuration". Further research could be useful to determine the best conditions to decrease electrodes degradation. Also, the effectiveness of PEF equipment is enhanced with low ionic strength and conductivity liquids. As a non-thermal treatment, PEF is beneficial for food samples treated, allowing to minimize temperatures rise and reducing the processing time (*Chotphruethipong et al. 2019*), it allows to reduce energy use, being energy efficient and environmentally friendly and to decrease processing costs (*Jambrak et al. 2018*). His effectiveness can be improved if combined with other techniques as HHPP, ultrasounds and thermal treatments (*Katiyo et al. 2017*). The process can be, with further studies, economically optimized, as costs are relevant in winemaking production (*Priyadarshini et al, 2019*).

2.2. PEF equipment parts and costs

The PEF equipment (Figure 2.2) is generally composed by a control and monitoring system, a high voltage pulse generator which is able to transform grid energy into short-length, high-peak power pulses, and the treatment chamber that delivers the pulses across the product to be treated (*Arshad et al., 2020, Kempkes, 2017; Silva and van Wyk, 2021*).

The pulse generator is the most expensive component, requires a correct set-up to make this technology economically optimized.

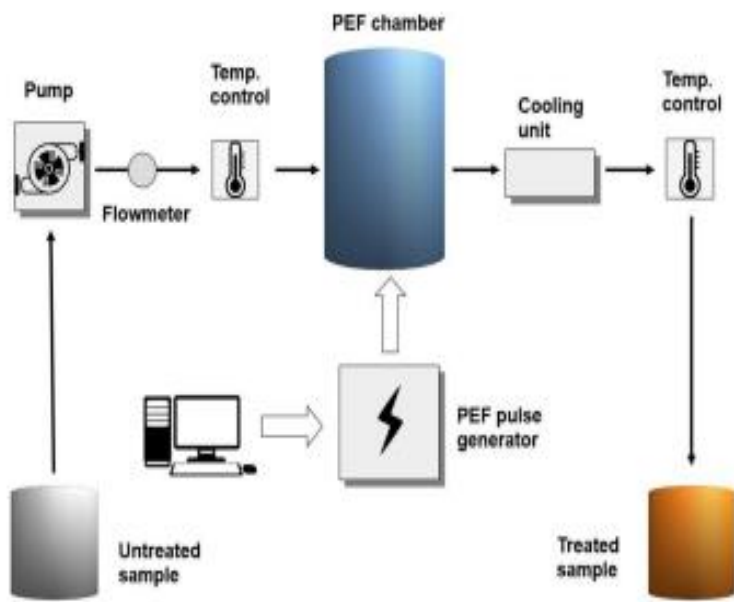

Figure 2.2. A typical PEF unit used in food processing (Nowosad et al., 2020)

2.2.1. Pulse generator

Electric fields generation requires a high voltage pulse generator to convert normal utility voltage into high intensity voltage, and supply direct current (D.C.), or a capacitor-charging power. The pulse generator is a component that delivers high voltage pulses to the treatment chamber (Barbosa-Cánovas et al. 1999). The energy required to achieve a certain result depends on the volume of treatment chamber, flow rate, treatment time and the configuration of the system.

2.2.2. Treatment chamber

The treatment chamber is the component where the product is effectively treated, and electric pulses are applied. It consists of two or more electrodes held in position by an insulating material that separates the chamber from the outside. Because of this, it is a fundamental element of the equipment, affecting parameters like field intensity and homogeneity, and, consequently, the efficiency of the process (Masood et al. 2018). Therefore, the insulator shape and the electrodes configuration are key points to consider (Esplugas et al., 2019). Also, the output of the pulse generator is controlled by the electric resistance of the treatment chamber, influenced by the electric conductivity of the liquid to be treated, as well as by electrodes characteristics like surface roughness and contamination by biological materials (Mooresan and Jayaram, 2013). Two main categories of treatment chambers can be distinguished (Figure 2.3): (i) batch chambers, filled with a given volume of liquid and emptied after the pulses are applied, in a non-continuous process, and (ii) continuous chambers, mainly used with liquids, able to flow into the

chamber and be processed (Huang & Wang, 2009), more interesting by a technological point of view. Depending on the treated product type (solid, or liquid), different treatment chambers can be used. Liquid foods, usually treated in continuous chambers, could have processing problems from non-uniformity of electric field distribution, caused by treatment chamber configuration, presence of impurities or bubbles or properties of the liquid (Zhang et al. 1995). Thus resulting in some parts of the sample non treated, or over-treated. Electric field uniformity is fundamental to obtain a good result. To overcome the problem, multiple chambers in series can be placed, or treatment chambers with parallel plate electrode configuration (Buckow et al. 2013).

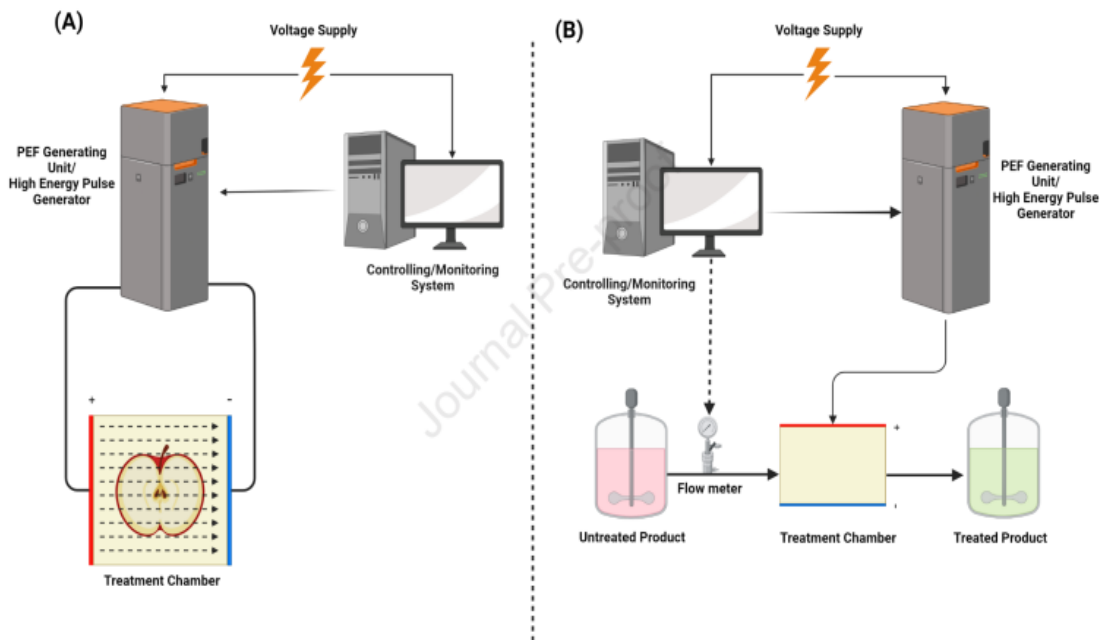

Figure 2.3 Batch and continuous chambers scheme (Naliyadhara et al., 2022)

During PEF processing, temperature changes of the food product have to be monitored to ensure a non-thermal treatment. As a result of ohmic heating, there is an increase of food temperature measured by the fluid difference between inlet and outlet temperatures (van Wyk et al 2019). The product can be cooled before and after the treatment, to prevent microorganism cell walls to be repaired (Alkhafaji, 2006).

2.2.3. Electrodes material, type and configuration

The electrodes are in direct contact with the beverage and transmit the electric fields to the food when passing through the treatment chamber (Silva and van Wyk, 2021). The choice of electrodes is influenced by several parameters like the targeted load, pulse generator restrictions, biocompatibility requirements (Zbinden, 2011) and electrolytic dissolution (Asavasanti, et al, 2014). For food treatment, electrodes should be designed and produced with food-grade materials, inert by an electrochemically point of view. Also, they should be easy to clean and sterilize. Initially, the electrodes with a short lifespan were fabricated using carbon, to avoid possible contaminations during the process. Best materials for electrodes would be precious metals, as gold, platinum, characterized by low resistance and minimal erosion at high voltage. However, the price of the equipment would

highly increase. Stainless steel, for its high erosion resistance and accessible price, can be considered one of the best options (Toepfl, Heinz, & Knorr, 2007). Nevertheless, with long operational time, a partial release of particles in the treated food has been evidenced (Gad, et al, 2014), so, it is important to predict and respect the lifecycle of the electrodes. Hence, it is important, after lifecycle expiration, to replace the electrodes with new ones even if, in large PEF systems, the low amount of particles released could be tolerable (Pataro & Ferrari, 2017).

Different types of electrodes can be found. Milli-electrodes are mainly used at laboratory scale, allowing the observation of cells under microscope while pulses are delivered, thus facilitating the studies of the dynamics of these phenomena (Barsotti et al, 1999). The disadvantages are represented by an inhomogeneous and poorly defined electric field (Toepfl, et al, 2006). To process larger samples of cells, micro-electrodes can be adopted. However, the most used to process food, at industrial level, are electrodes built into flow-through chambers, adopted when large volumes of cells in a liquid food need to be electroporate. It has to be underlined that, when treating food, metal release could represent a problem and needs to be monitored for specific processing conditions and applications (Fernandes, 2015).

In flow-through chamber, three main electrode configurations are common (Table 2.1), (Huang & Wang, 2009, Kanduser et al, 2017).

Table 2.1 Common characteristics of different electrode configurations (Arshad et al., 2020)

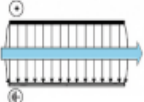
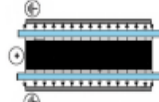
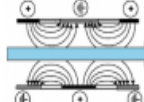
Characteristics	Parallel plate	Coaxial	Co-linear	References
Liquid flow with the direction of the electric field	Right angle	Right angle	Parallel	Bermaki et al. (2017)
Electric field distribution	Uniform	Almost uniform at large radii	Non-uniform	(Morales-de la Peña et al., 2017)
Mathematical calculation for the average values of electric field strength	$\frac{V}{d}$ Where V = applied voltage; d = gap between electrodes	$(V) / \left(r \ln \left(\frac{R_o}{R_i} \right) \right)$ Ro and Ri are outer and inner radii respectively; $R_i < r < R_o$	Not possible but can estimate through numerical analysis	Masood et al. (2018)
Number of electrodes	Maximum = 2	Maximum = 2	Minimum = 2 with an insulator	Sack & Mueller et al. (2017)
Electrical resistance	Low (ohms)	Low (ohms)	High (hundreds of ohms)	(Novickij et al., 2016; Toepfl et al., 2007)
Cross-sectional geometry with a continuous flow of liquid food				(Toepfl, Siemer, Saldana-Navarro, & Heinz, 2014)

According to Arshad et al. (2020), the first, parallel plates configuration, offers the most uniform distribution of the electric field, no matter the gap between the electrodes is. This configuration allows a low electric resistance in the treatment chamber (Masood et al., 2018). Thus, possibly causing a corrosion problem of electrodes at electrode-treated liquid interface level, resulting in a minerals and metals release towards the treated product.

The second, coaxial chamber, is composed by two sunken cylinders, with the food moving axially along the treatment chamber, hit radially by the magnetic field. This system is characterized by a less uniform electric field distribution, that decreases from internal to external cylinder (Morales-de la Pena et al., 2017). The last, co-linear electrode configuration is composed by several electrode rings isolated by insulating rings (Mc Hugh & Toepfl, 2016). This configuration allows to process large quantities of product, due to large treatment capacity and lower effective cross-sectional area of the electrodes, positive for continuous food processing (Gongora-Nieto et al,

2002). The co-linear treatment chambers, characterized by a large insulator and a small electrode surface, offer high electrical resistance loads. As a result, a lower amount of current is required, favourable for the development on large-scale pulse moderator, applied in food treatment (*Sack & Mueller, 2017*). Also, some non-uniform electric field distribution can happen with subsequent under-treated regions, usually in the centre or dead spaces, requiring a higher voltage to cover them.

2.2.4 Equipment costs

According to *Kempkes (2017)*, the cost of PEF processing is made up of two major elements: the capital cost for level of capacity (in \$ /ton/hour) and the cost of electricity needed to provide the treatment. However, they are very compact if compared to other thermal pasteurizers, so facility costs are not a significant issue. The biggest element in cost calculation is capital cost for the PEF system. PEF system capacity directly affects the capital cost. In fact, higher capacity means higher peak and average power in the system, which directly impact the power supply and modulator costs. So, large systems are more expensive than smaller ones even if costs do not increase linearly with power

Capital cost of a large industrial system is generally smaller than its electricity bill over its lifetime. *Kempkes* reports, for a 200 kW PEF system, cost around \$7–\$10 per hour of operation, while electricity cost would be approximately twice (per hour), depending on local electricity rates. The total cost of 20-30\$/operating hour, divided by the amount of processed product in that time. Also, a PEF system should have a lifetime around 10-20 years, so the cost decrease after the depreciation period.

2.3. PEF Process parameters

There are several parameters to be set when applying PEF, which are able to influence the effectiveness of the treatment in terms of microbial/plant cell electroporation and the quality of the treated product. The calculation of real treatment time in a continuous process requires information regarding the PEF pulse frequency and width, the flow rate and the volume of the treatment chamber and will be explained in this section.

2.3.1 Electric field strength or intensity

The electric field strength, E , at a point in the field is defined as the force per unit charge on a positive test charge placed at that point (*Electric Field strength | Physics Wiki | Fandom*). The applied strength of an electric field should be modulated according to the desired outcome. Electric field strength E is defined as the electric potential difference U for two given points in space divided by the distance d between them (*Equation 2.2*).

$$E = U / d \quad (2.2)$$

Several studies evidenced that, to achieve cell electroporation contained in a liquid food, the applied electric field has to exceed the critical transmembrane potential, to generate irreversible poration in the cell walls. Thus, directly

increasing with the increase in the field strength (*Wouters & Smelt, 1997, Dunn & Pearlman, 1987, Yin, Zhang & Sastry, 1997*).

2.3.2 Pulse wave shape and width

Pulse wave shapes are squared or exponential decaying, and can also be mono- or bi-polar (*Figure 2.4*) Among the mentioned above waves, squared shapes, characterized by fast-rising and falling edges are the most efficient,

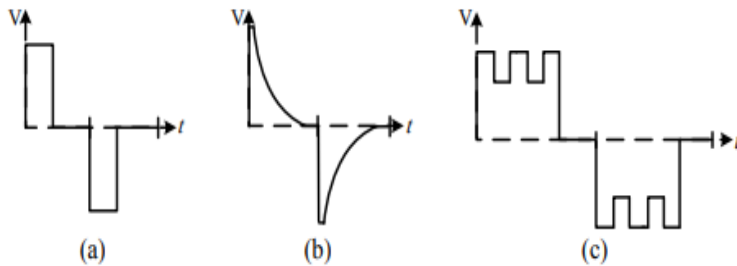

Figure 2.4 Common pulse waveforms in PEF applications (Kumar et al., 2015)

responsible for a lower temperature increase and release towards the liquid (*Kempkes, 2017*). Alternatively, exponential pulses produce a short peak of high-intensity electric field and a tail with a lower electric field intensity. Thus part of the pulse, with low electric field intensity (the tail), is not effective for the treatment. The PEF process will be less efficient, although this is the simplest and cheapest wave shape to produce (*Eigenedy et al., 2017*). In 1996, *Pothakamury* studied the effect of different pulse shape on *Escherichia coli* in milk. The results showed that, after the treatment, square-wave pulses produced 2 log reduction, while just 1.2 log reduction was found out when using exponential decaying pulses.

The corrosion of the electrodes is reduced when bi-polar pulses are applied, because of the possibility to swap cathode/anode, preventing charge accumulations and thus slowing down the degradation of the electrodes (*Zhang et al, 2018*).

Pulse width can be defined as the elapsed time between the rising and falling edges of a single pulse. Pulse width (τ) is expressed as the function of both discharging circuitry and resistivity of the processed food sample and defines, together with the applied frequency, the residence time, and ultimately the treatment time. With a fixed electric field strength, treatment time increases by increasing both pulse width and/or frequency, promoting an increase in the formation of cells' pores (*Wouters & Smelt, 1997*). During PEF treatments, it was shown by *Guionet et al, 2015*, that wider pulses contribute more to the total energy input, resulting more effective in irreversible electroporation. However, when a high electric field is applied, heat release and electrolysis limit the length of pulses to microseconds.

2.3.3 Pulse frequency

Pulse frequency is the number of pulses per second. Generation of a PEF pulse is characterized by a slow charging of the system, and a fast high-energy discharge which corresponds to the pulse (*Alkhafaji, 2006*). More energy can be delivered to the food by increasing the pulse width, raising the peak power in each pulse, both directly

increasing the cost of pulse generator and processing system. One other option is to increase the pulse frequency (Gaudreau et al. 2005), recommended to provide a solution with lower energy consumption.

2.3.4 Treatment time

To determine the treatment time in a continuous process three calculations are needed (Silva and van Wyk, 2021). First the residence time is calculated from the ratio of the treatment chamber volume (V) and the liquid flow rate (Q) (Equation 2.3)

$$\text{Residence time} = V_{(\text{treatment chamber})}/Q \quad (2.3)$$

Then the number of pulses (n) is calculated by the product of pulse frequency (f) and residence time (Equation 2.4)

$$n = \text{residence time} \times f \quad (2.4)$$

And lastly the real treatment time (t) is obtained from the product of pulse width (τ) by the number of impulses (n) (Equation 2.5)

$$t = n \times \tau \quad (2.5)$$

Jeantet et al. (1999), applying treatments with the same intensity with higher and lower number of pulses to *Salmonella enteridis* in egg white, observed that the higher the number of applied pulses, the higher the microbial inactivation.

2.3.5 Energy density

Energy density (J/L) is a useful parameter (Equation 2.6), and can be estimated from the parameters described in previous section.

$$\text{Energy density} = \frac{U \times I \times \tau \times n}{V} \quad (2.6)$$

Where: U= electrical potential difference (V)
 I= Current (A)
 τ = pulse width (s)
 n= number of pulses
 V= volume of treatment chamber (L)

2.4 PEF processing for wine production: effects on wine quality

PEF technology was introduced in food processing with the purpose of microbial inactivation (*Ortega-Rivas & Salmerón-Ochoa, 2014*), with aim to achieve better preservation of food colour, flavour, nutritional values compared with traditional thermal methods for food processing (*Maged & Amer Wissa, 2012*). However, electroporation has been used to increase extraction yield in fruit juices production (*Schilling et al, 2007*) and for extraction of bioactive compounds from plant and algae materials (*Vorobiev & Lebovka, 2012*), extending the application possibilities of this technology.

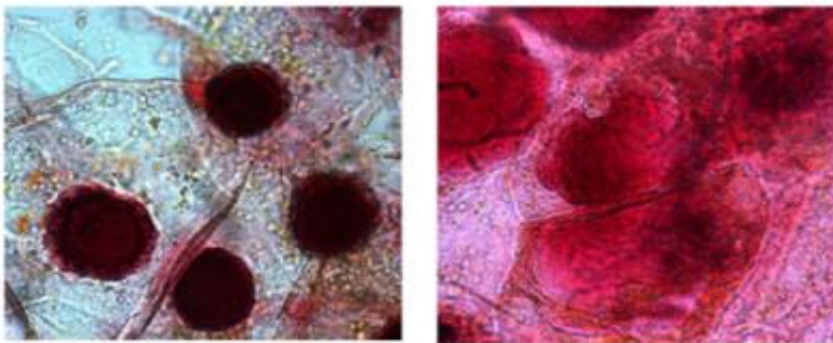

Figure 2.5 Microscopic photos of peel tissue of Lemberger wine grapes before and after electroporation (Ozturk & Anli, 2017)

The interest of pulsed electric fields is increasing. The motivation could be that PEF processing of grapes and wine was not in the “recommended practices” list drawn up by OIV, and therefore not allowed at winery scale in Europe. Lately, with resolution OIV-OENO 634-2020, OIV (2020) has admitted the use of this technology at grape level, to facilitate and increase the extraction of valuable substances such as polyphenols, yeast available nitrogen, aroma compounds including precursors, and other substances located inside the grape cells and, in case of red varieties, to reduce maceration time as well (*Figure 2.5*). However, the use of this processing method on white grape varieties and its effect on must and wine composition has been poorly investigated and needs therefore to be deepened, as well as the use of this technology for wine processing to inactivate microorganisms, before bottling.

2.4.1 Effect of electrical conductivity of the wine on process efficiency

Electric conductivity can be expressed as the ability of a food material to carry a current. This ability is conferred by ions present in the sample and, as discussed by *Bruhn et al. (1998)*, seems to be necessary to increase the transmembrane potential and the effectiveness of the treatment. Decreasing the medium conductivity enhances the differences between the microbial cytoplasm and the food beverage medium, increasing the ionic flow across the microbial membrane. Thus, causes an additional pressure, due to osmotic forces caused by the ionic flow, enhancing the cell sensitivity towards the treatment and subsequently the efficiency of electroporation. Additionally, a low food electrical conductivity allows to apply stronger electric fields, increasing the electroporation effect of PEF. Also, it reduces ohmic heating of the beverage, and possible thermal damages. A temperature increase, due to the heat transfer during the PEF treatment, also causes an increase in the beverage electrical

conductivity, requiring a higher energy input to achieve the same results. *Huang et al. (2013)*, *Li & Farid (2016)* showed that more energy is dissipated/lost in the form of heat to the beverage when the electrical conductivity of the liquid food medium is higher, increasing the treatment and beverage temperature, which is not desirable.

Complex liquid food matrices, containing several different components, make the application of the treatment more complex than a simple buffer solution. The presence of molecules, like proteins and lipids, appeared to increase the resistance to electric pulses, reducing the beverage electrical conductivity. Other compounds, such as ions, result in an increase in the beverage electrical conductivity, diminishing the lethal effect of PEF (*Martin et al, 1997*, *Grahl & Markl, 1996*). Alcohol present in wine also affects the wine electrical conductivity. A study of *Huang et al, (2013)*, evidenced that an increase in the alcohol content, from 10.5 to 14% v/v led to a linear decrease of conductivity from 2.04 to 1.80 mS/cm, which is positive for PEF performance. Also, alcohol is able to weaken the integrity of microorganism membranes, enhancing the cell vulnerability to electroporation (*Longin et al, 2016*).

2.4.2 Effect of PEF on yield of grape juice extraction

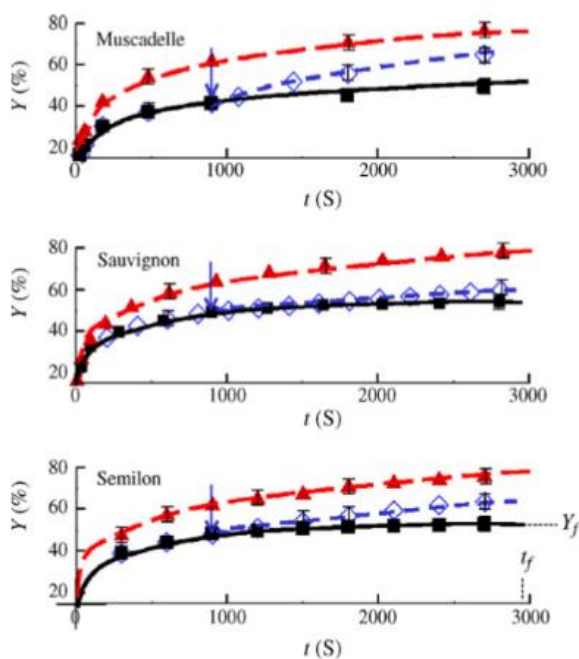

Figure 2.6 Juice yield Y (%) vs. expression time t (s) in the pressing experiments without PEF-treatment (\blacksquare), with PEF pre-treatment (\blacktriangledown) and intermediate PEF treatment (\diamond) for Muscadelle, Sauvignon and Semillon grapes (*Praporscic et al., 2006*)

According to OIV resolution cited above, the technique consists of the application of pulsed electric fields in range of nanoseconds to milliseconds with the aim to permeabilize grape skin cells' membranes. This allows to have a better extraction during pressing process. A study was conducted by *Comuzzo et al., (2018)*. The experiment compared an untreated grape sample with grape samples treated with PEF at different intensities (1.5 kV/cm for 8 and 16 μ s), before pressing. The percent yield in juice from control sample, the untreated one, was 78%, increasing to 84.9% for the sample PEF processed at 11kJ/kg and to 81.4% in sample treated at 22 kJ/kg, showing an increase in both samples where PEF was applied. It is interesting to underline that the higher results were obtained applying a weaker specific energy (11 kJ/kg). *Praporscic et al.,(2006)*, in a lab-scale experiment conducted on Semillon, Sauvignon and Muscadelle varieties, observed, applying PEF before the treatment and as intermediate treatment at 0.75 kV/cm,

that yield always increased when PEF was applied before the pressing phase (+24%) (Figure 2.6). Based on both results, we can conclude that lower electric field intensities might be a more suitable operating condition to increase juice extraction yield. Also, *Praporsic et al.* discovered that with pre-treatment PEF application, the treatment produced a decrease in must turbidity after pressing, disagreeing with *Comuzzo et al., (2018)* where a higher level of turbidity was detected in PEF-processed grapes, maybe due to the different varieties or pressing machines

used. In 2009, *Grimi et al.*(2009) also investigated the influence of PEF application on Chardonnay grapes, varying the extraction regimes: constant pressure at 0.5-1 bar and progressive pressure, increasing up to 1 bar. The results of constant pressure application showed an increase of 18% yield in PEF treated grapes, without affecting turbidity and polyphenols content, while the most significant effect observed with progressive pressure application was a rise of 15% in polyphenol content, with similar yield. As an increase in this parameter could result in a quality decrease, constant pressure seems to be a more valid option for this practice. The use of PEF has also been tested in combination with enzymatic treatment with pectinase, in two white grape varieties, namely Gruner Veltliner and Traminer. Results showed an increased turbidity in combined samples of Traminer by 17%, without other relevant effects (*Fauster et al., 2020*). The variability of results reported in the paragraph on the application of PEF on white varieties indicates that an optimization of PEF treatment conditions is required and parameters such as the grape variety and pressing characteristics could play a key role in the application of this technology to improve juice extraction without increasing the turbidity.

2.4.3 Effect of PEF on aroma of wine

2.4.3.1 Sensory perceptions of wine

Sensory evaluation is a discipline used to quantify, analyse and interpret reactions to stimuli through senses (*ASTM, 2000*). Similar to wine chemical analysis, sensory analysis is useful to characterize a wine (descriptive tests), and to compare wines produced in different ways, for example using PEF (discriminant tests), to rank wines according to preference or a specific attribute, etc

In a triangular test carried out by *Luengo et al., (2013)*, comparing control wine (no PEF, 14 days of maceration), PEF (7 days of maceration) and PEF (14 days of maceration) applying 4.3 kV/cm, 60 μ s were compared. Among the samples, significant sensory differences between PEF-7 wine and both control and PEF-14 wine were detected. However, panellists were not able to differentiate the two wines elaborated with a maceration time of 14 days. Where the panellists were asked to indicate their preference, the majority of panellists chose the wine with a 7 day maceration, maybe due to the higher extraction of phenolic compounds by seeds in the other two samples and therefore, the higher preference for 7 days maceration PEF treated wine could be related to the lower concentration of seed proanthocyanins in the wine. In another study, PEF (46.8 kV/cm, 20.5 μ s treatment time) was applied to Cabernet Sauvignon before bottling and wine stored for one year. After, samples were presented to twenty-eight qualified candidates to determine differences between control and PEF treated wines, that were not able to detect a significant difference.. Only 13 out of 28, the 46% of panellists, were able to identify the different sample out of the three presented, which means there was no significant difference between the overall taste of the 2 wine samples. In a study by *Fauster et al., (2020)*, Traminer and Veltliner grapes were treated with PEF before pressing for juice extraction(3 kV/cm, other specifications in the chapter below). Then, the wine produced were given to the panellists, that were not able to detect differences, astringency, or bitterness in the different wines.

Abca & Evrendilek (2014) subjected different wines, without PEF and with PEF treatment (17, 24 and 31 kV/cm, 8 μ s) to sensory analysis. For visual evaluation, panellists were asked to evaluate the samples for being cloudy or clear (cloudiness/clearness), dull or bright (dullness/brightness), red colour intensity and density of particles. For smell, they were asked to take a quick whiff to gain a first impression and take a deep breath to receive the whole impression, and finally, they were asked to taste them. No significant differences were found except for red colour intensity, higher when PEF was applied, and a slight change in bitterness and sour taste.,

2.4.3.2 Aroma compounds

Although many chemical compounds are present in wine, only a few of them contribute to the sensory perception of wine flavour. These compounds are found in grapes in the form of non-odorant precursors, which will be transformed by yeasts metabolic activity during fermentation, into aromatic compounds of great relevance for the final wine sensory perception.. *Comuzzo et al., (2018)*, investigated the content of thirty-two volatile compounds, fifty days after the end of alcoholic fermentation (AF). The application of PEF as a pre-treatment before pressing phase (1.5 kV/cm in continuous flow, 200L/h) poorly affected the alcohols content in wine, and the variations observed in the results, did not appear to be relevant by a practical point of view. It is important to observe that the PEF treatment did not significantly affect the concentration of C6 pre-fermentative alcohols. Cis- and trans-3-hexen-1-ol are compounds characterized by green and herbaceous notes (*Ribereau-Gayon et al., 2006*), and their presence in high concentration, above odour threshold (400 μ g L⁻¹) (*Guth, 1997*), might compromise wine quality.

For fatty acids, significant variations were found for octanoic (responsible for cheese-like and harsh off flavour (*Tao & Zhang, 2010*)) decanoic and butanoic acid present in lower concentration in PEF treated wine. The opportunity to reduce these compounds concentration might appear interesting, however, the mechanism for such behaviour remain unclear and further studies need to be carried out. In addition, the concentration of selected volatile phenols, namely 4-vinylphenol and 4-vinylguaiacol were also significantly reduced by PEF processing. These molecules are associated to pharmaceutical olfactory off notes. It is known that the presence of these compounds in white wines derive from enzymatic decarboxylation of cinnamic acids by yeasts (*Ribereau-Gayon et al., 2006*). PEF processing allowed to obtain a concentration below the odour threshold, impacting in a positive way on the overall perception of wine. This modification is probably connected with the reduction of hydroxycinnamic acid precursors concentration in the juice, via oxidation.

With respect to varietal aroma precursors, the most representative molecules found through analysis were linalool and geraniol. Free linalool concentration was not affected by PEF treatment. By contrast, geraniol content significantly increased, up to +50%. In general, even if Garganega is not an aromatic variety, PEF allowed to obtain a total concentration of free and bond form aroma precursors higher than in control. (*Comuzzo et al., 2018*).

Fauster et al. (2020) examined the impact of PEF used in combination with pectins degradative enzymes on two white varieties, Traminer and Gruner Veltliner. Grapes were treated in a co-linear PEF treatment chamber (3 kV/cm, 3 and 10 kJ/kg, 440 kg/h) followed by the addition of pectolytic enzymes just after PEF treatment, and pressing of the grape mash conducted after 4 and 24 h of skin contact at 15°C. From results, they noticed that Gruner Veltliner fermentation kinetics has not been affected, while for Traminer grape variety a 20% reduction of

fermentation time was observed. This effect is related to an increment, around 10%, in total nitrogen released from the PEF treated grapes to the juice. The treatment also promoted the release of those polyphenols mainly located in the grape pulp. In the case of Traminer, an increase in the concentration of some esters and a significant increment of all analysed terpenes were observed, but was not detectable, neither analytically nor sensorially, after 3 months in bottle. For Gruner, no differences were detected.

2.4.4 Effect of PEF treatments on colour and physico-chemical characteristics of must and final wine

2.4.4.1 PEF extraction of must before pressing

PEF application at early stages of wine production to the grapes aims to facilitate and increase the extraction of valuable compounds such as aromas and their precursors, polyphenols, yeast available nitrogen and other substances located inside grape pulps and skins (OIV, 2020). According to Comuzzo *et al.*, (2018), (experiment on white variety, Garganega), PEF extraction of grape juice produced wine with higher level of total phenols, and a more intense colour than wine produced from conventional extraction (Table 2.2). Contrarily, Prapovic *et al.* (2007), found out that PEF pre-treatment of three white grapes varieties, Sauvignon, Muscadelle and Semillon, led to a lower colour extraction. It has to be mentioned that the experiment conditions were different and, according to Teissie *et al.* (2005), there are different parameters affecting the results of the treatment, such as the medium composition, with particular respect to the electrical conductivity. Also, the authors used different presses, which also have played a fundamental role in the extraction processes.

Table 2.2 Colour (Abs 420 nm), total phenols index (TPI) and POM-test (Polyphenols Oxidative Medium test) of wines produced from untreated (control) and PEF-processed (PEF 11 kJ/kg and PEF 22 kJ/kg) grapes, fifty days after alcoholic fermentation (Comuzzo *et al.*, 2018)

sample	Abs 420 nm	TPI	POM-test
	mean \pm SD	mean \pm SD	mean \pm SD
Untreated	0.146 \pm 0.007a	8.7 \pm 0.2a	24.6 \pm 2.1b
PEF 11	0.377 \pm 0.003c	20.3 \pm 0.1c	4.6 \pm 0.2a
PEF 22	0.261 \pm 0.010b	12.0 \pm 0.1b	8.3 \pm 3.8a

The difference in wine colour could be explained by the theory that lower specific energy (11 kJ/kg) is able to generate, on grape surfaces, smaller pores. Thus, resulting in a higher release of water and small phenolic molecules. Such small molecules might be easily oxidized, provoking a more intense browning in the wine. By contrast, the larger pores originated by processing grapes at higher intensity (22 kJ/kg) might promote the release of bigger, more complex molecules, less susceptible to oxidation phenomena and thereby reducing the intensity

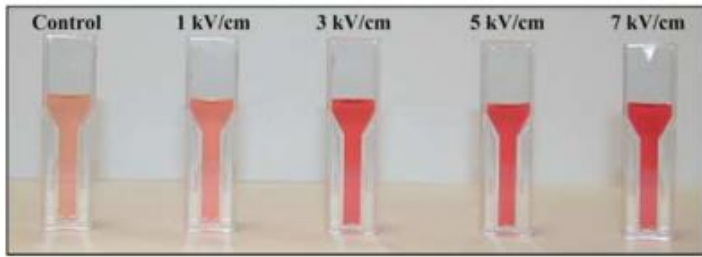

Figure 2.7 Image of Garnacha must after 1 h of maceration with untreated and PEF-treated (1- 7kV/cm) grapes prior to extraction (Ozturk and Anli, 2017)

of browning reactions (Plumb *et al.*, 1998). Also, Ozturk *et Anli*, (2017) applying PEF at different intensities before pressing, had relevant differences in the results after 1h of maceration (Figure 2.7).

The extraction of substances from grapes such as flavouring compounds and colour pigments is fundamental for the wine production industry (Jackson *et al.*, 2008). Phenolic compounds confer to red wines important organoleptic properties, such as colour, astringency, bitterness mouthfeel and aging ability (Sarni-Manchado *et al.*, 1999). Additionally, they offer wine protection towards oxidative phenomena and bacterial spoilage, thanks to their antioxidant and antimicrobial effect, conferring an essential contribution to aging capacity (Boulton, 2001, Vidal *et al.*, 2004).

According to Cerpa-Calderon & Kennedy, (2008), during traditional winemaking, just a part of compounds of grape skins are transferred to the must, about 40% of anthocyanins and 20% of tannins. The use of PEF before alcoholic fermentation for the extraction of grape juice and must production enhance the extraction of these compounds, as demonstrated by El Darra *et al.*, 2016. The application of electric fields during cold maceration (CM) and alcoholic fermentation led to an increase in TPI and CI in Cabernet Sauvignon whenever the PEF was applied, increasing the content and the extraction kinetics of these compounds.

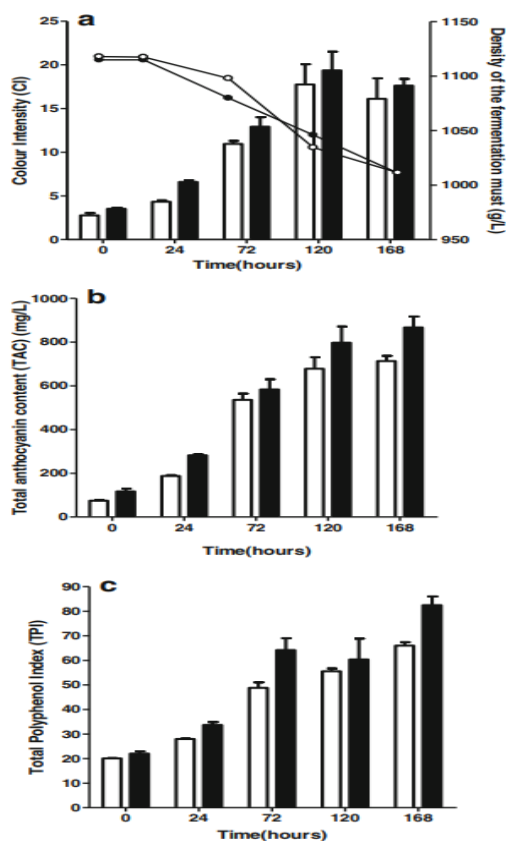

Figure 2.8 Evolution of colour intensity (CI) – a, total anthocyanin content (TAC) - b, total polyphenol index (TPI) - c, along fermentation–maceration time during the first 7 days of vinification of untreated Garnacha grapes (empty bars) and grapes treated by PEF (full bars). Figure a also shows evolution of must density during fermentation. Error bars correspond to standard deviation of the mean (Luengo et al., 2013)

Luengo et al. (2013) carried out a PEF extraction study on Grenache grapes variety using a co-linear chamber, at industrial scale, with application of 4 kV/cm electric field. It showed that concentration of anthocyanins reached the maximum value after 5 days, remaining constant afterwards. Anthocyanin level of PEF treated wine was 25% higher than in control, and 23.5% for TPI (Figure 2.8). Anyway, it is important to underline that, especially for phenolic compounds deriving from seeds, their release is ethanol dependant and usually only occurs when yeasts start to ferment (Busse-Valverde et al., 2010). Boussetta et al., (2012), investigated the PEF effect on polyphenols released by seeds, that required much higher electric field intensity (8-20 kV/cm) to electroporate skin cells. According to these results, the intensity used in this study (4 kV/cm) should not have affected the extraction of polyphenols from grape seeds. Finally, colour intensity was 12.5% higher than control and the results of the treatment applied (PEF + 7 days maceration) was similar to control (no PEF, 14 days maceration).

According to Puértolas et al. (2010), a pilot-scale PEF unit may develop a wine with a high phenolic content. 50 pulses at 5 kV/cm (122 Hz, 3.67 kJ/kg, 30 °C) were applied to the crushed Cabernet Sauvignon grapes before potassium metabisulfite was added and fermentation began. A finished wine that required less maceration time and had a higher Folin-Ciocalteu index, polyphenol concentration, and colour intensity was created by treating Cabernet Sauvignon grape juice with skins using square pulses at 5 kV/cm for a residence time of 0.41 s (122 Hz, 50 pulses, 3.67 kJ/kg, 17 °C). Wine quality factors were examined by Lopez et al. (2008) after subjecting grape skins to PEF treatment (10 kV/cm, 50 pulses, 1 Hz, 6.7 kJ/kg, 30 °C). The prior PEF treatment decreased the amount of time that the wine was allowed to macerate during vinification and increased the amount of phenolic compounds in the finished product. The final wine produced had higher colour intensity, total phenolic content, tannins, and anthocyanins thanks to the treatment of Cabernet Sauvignon grape pomace with a low electric field strength of 5 kV/cm. Additionally, PEF treatment of grape pomace allowed López et al. (2009) to cut the necessary maceration period from 268 to 72 hours.

2.4.4.2 PEF treatments of wine before bottling

For the objective of microbial inactivation and wine stabilization for a longer period of shelf-life, *Van Wyk et al. (2021)* applied PEF to three different red (Syrah, Pinot Noir) and white (Sauvignon Blanc, Pinot Gris) wines. The authors applied 46 pulses over an actual treatment time of 70 s to the wines using a 45 kV/cm and 800 Hz frequency. In comparison to the untreated wines immediately after processing, PEF had no impact on the overall phenolic content or pH of any wines. The antioxidant activity of PEF-treated wines did not vary, except for a drop in Syrah from 9.3 0.2 to 0.4 0.1 mmol TE/L. PEF boosted the colour density of white wines (Sauvignon Blanc 0.08 0.00 to 0.20 0.00 and Pinot Gris 0.26 0.00 to 0.37 0.00) as well as red wines (Syrah 7.80 0.09 to 8.71 0.02 and Pinot Noir 4.68 0.00 to 5.14 0.05). The PEF treatment stabilized the wine during this time, as evidenced by the antioxidant activity of treated and untreated wines being comparable after two months of storage.

Delsart et al., (2015) also investigated the impact of PEF on quality characteristics, applying 20kV/cm to a wine, prior bottling, to inactivate all micro-organisms present in wine. Analysis showed a slight change in PH, increasing of 1%. Contrarily, total acidity decreased of 5%. Tartaric acid increased of 16%, while lactic decreased of 11%. Following the treatment, volatile acidity decreased of 17%. Consequences of the treatment on colour were studied by measuring concentration of anthocyanins and tannins, colour intensity and total polyphenol index. PEF treated wines showed similar or superior (5%) anthocyanin concentration, as well as for tannins, where an increase from 4 to 8% was registered. Colour intensity was similar, and total phenols index ranged from 6%decrease to 5% increase.

After being exposed to a pulsed electric field for 10 seconds at a frequency of 20 pulses per second and two electric field strengths of 3.3 kV/cm and 5 kV/cm, grapes (Marechal Foch variety) underwent fermentation in accordance with the practices employed in the wine business. The colour components were determined, including *a, *b and *L parameters, in all analysed wine samples after 8 weeks of fermentation, using CIE Lab. It was shown that brightness of wines equals respectively to 11.96 ± 0.02 for control wine, 11.66 ± 0.00 for 3.3 kV/cm wine, and 11.23 ± 0.01 for 5 kV/cm wine treated. Also, the red component in the three samples cited above increased. The highest share of red colour component was observed in wine treated at 5 kV/cm (*Figure 2.9*).

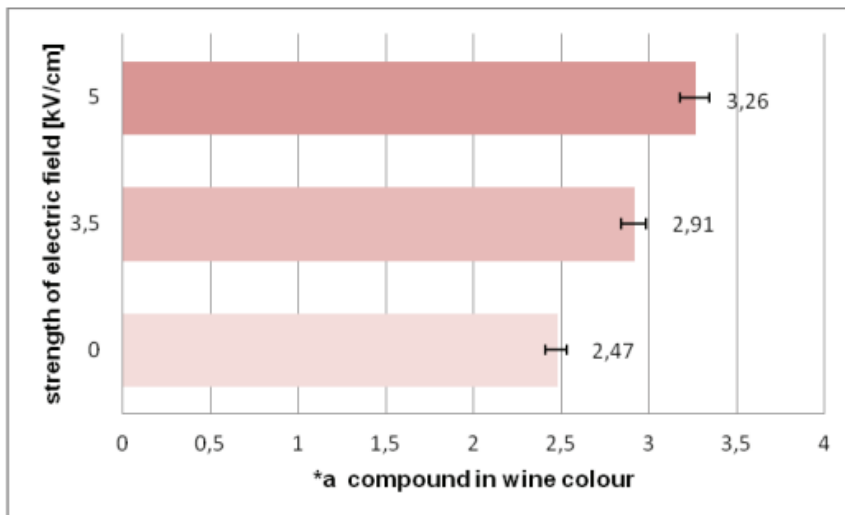

Figure 2.9 Share of red component *a in colour of control, 3.3 and 5 kV/cm PEF treated wines (Ilona, G., Ewa, K., & Andrzej, C. 2018)

Another PEF extraction study, performed by *Lopez et al.*, (2008) on three red varieties, Grenache, Mazuelo and Graciano, with application of PEF at 2, 5 and 10 kV/cm, confirmed the observations of other authors, which show that the electric field needed for extraction is much lower than the one needed for microbial inactivation. So, the application of PEF at 2, 5 and 10 kV/cm was enough to increase colour intensity, anthocyanins and total polyphenols, underlining that the influence of PEF intensity applied depended on the grape variety investigated. In fact, the application of PEF was more effective on Mazuelo variety, rather than Grenache or Graciano. Another interesting aspect to consider is the intensity applied, to elucidate whether higher electric field strengths cause an increase in the number of pores formed, or in the size of pores. In Grenache and Graciano, in fact, an application of PEF increased the permeabilisation of cells, but further increments in the electric field applied did not generally result in higher extraction of phenolic compounds.

2.5 Effect of PEF treatment of wine on microbial inactivation and potential SO₂ reduction

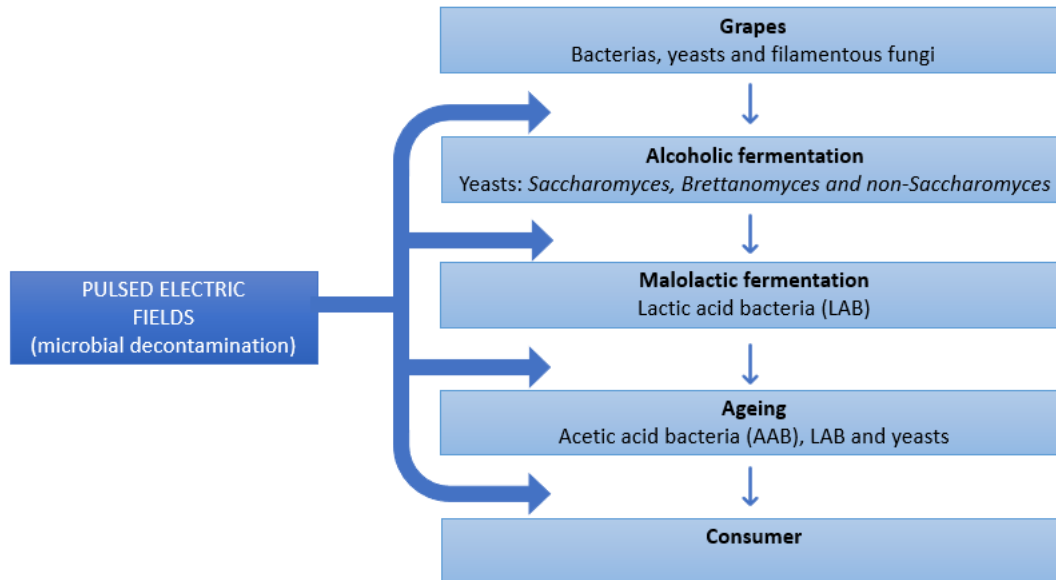

Figure 2.10 Steps of winemaking in which pulsed electric fields have potential application for microbial control and decontamination (adapted by Delso et al. 2021)

Winemaking is a complex microbial process in which microorganisms, like yeasts and bacteria, play a key role. After the crushing phase, yeasts as *Saccharomyces* metabolize sugars producing ethanol during alcoholic fermentation. However, different yeast and bacteria strains, including *Metschnikowia*, *Candida*, and *Hanseniaspora* are usually present in the initial phase of fermentation (Ribéreau-Gayon, Glories, & Maujean, 2006). These species are usually present on grapes surfaces and/or cellar environment, being dominated by one or more *Saccharomyces cerevisiae* concurrently with alcohol increase (Bisson & Kunkee, 1993). Some of these microorganisms are able to survive during fermentation, although in a lower number than *Saccharomyces* strains, due to their weaker resistance to ethanol (Malfeito-Ferreira, 2014). Both microbial groups, bacteria and yeasts, are involved in the aromatic profile modifications responsible for some sensorial wine properties. When fermentation stages finish, microbial population has to be reduced because post-fermentation microorganism development is usually negative for wine organoleptic characteristics (Renouf et al., 2007), producing spoilage defects as haze formation, increase in volatile acidity and so on (García-Ruiz et al., 2011). To prevent these spoilages, and subsequent quality loss, wine preservation technologies have relied on sulphur dioxide addition. Nevertheless, the worldwide trend is to reduce the use of SO₂ in wine due to the increase in health concerns, possible organoleptic alterations in the final product, consumer preference and restrictive legislation on preservatives (García-Ruiz et al., 2013). For this reason, there is an interest in the scientific community in the development of alternatives to the use of sulphur dioxide. Therefore, in order to meet consumer needs and increase the product quality, wine industry is attempting to find new strategies to reduce or eliminate the use of SO₂ (Silva

and van Wyk, 2021). PEF technology has potential for being used in the wine production at different stages (Figure 2.10). PEF technology can be used in several steps of vinification for microbial decontamination and/or control of the microbial population in must and wine.

2.5.1 Application of PEF for decontamination of must

According to Marsellès-Fontanet et al., (2009) a reduction rate ranging from 2.0 to 4.0 log were obtained applying PEF (35kV/cm, 1 ms) in musts containing a mixture of spoilage bacterias and yeasts, such as *Lactobacillus plantarum*, *Lactobacillus hilgardii*, and *Gluconobacter*, *Saccharomyces cerevisiae* and *Kloeckera apiculata*. Puertolas et al., (2009) also established an optimum field intensity at 29 kV/cm, reducing 99.9% of microorganisms in the artificially contaminated must (Figure 2.11).

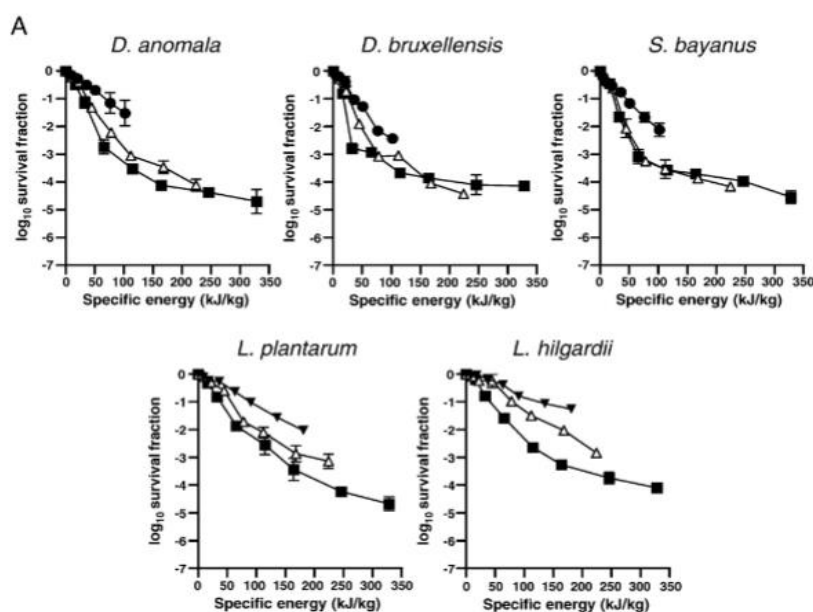

Figure 2.11 Survival curves of the studied microorganisms at different electric field strengths: 16 kV/cm (●), 22 kV/cm (▼), 25 kV/cm (△), 31 kV/cm (■). Treatment conditions: must, 1.97 ± 0.23 mS/cm (Puertolas et al., 2009)

Studies in actual condition of winemaking, aiming to stabilize the must before alcoholic fermentation, replacing SO₂ prior to alcoholic fermentation has been conducted to try, also, to facilitate the growth of culture starters. PEF (35 kV/cm, 1ms) was shown to be effective, without modifications in terms of volatile profile and physico-chemical characteristics (Garde-Cerdán et al., 2008). Also, in the last decades a new trend, based on the use of non-*Saccharomyces* strains for alcoholic fermentation to improve the sensorial profile of wines produced from neutral varieties. Some studies confirmed non-*Saccharomyces* yeasts were able to grow better in PEF treated musts. Therefore, must stabilization by PEF can be considered as a good alternative for the reduction of the SO₂ dose.

An experiment carried out with an electric field ranging from 0 to 31 kV/cm and temperature from 10 to 30°C, showed a proportional decrease in log number of colonies of all bacteria investigated (*Escherichia coli*, *Candida lipolytica*, *Hansenula anomala*, *Lactobacillus Delbruekii bulgaricus* and *Saccharomyces cerevisiae*) when field strength and temperature were increased (Abca et Evrendilek, 2014) (Figure 2.12).

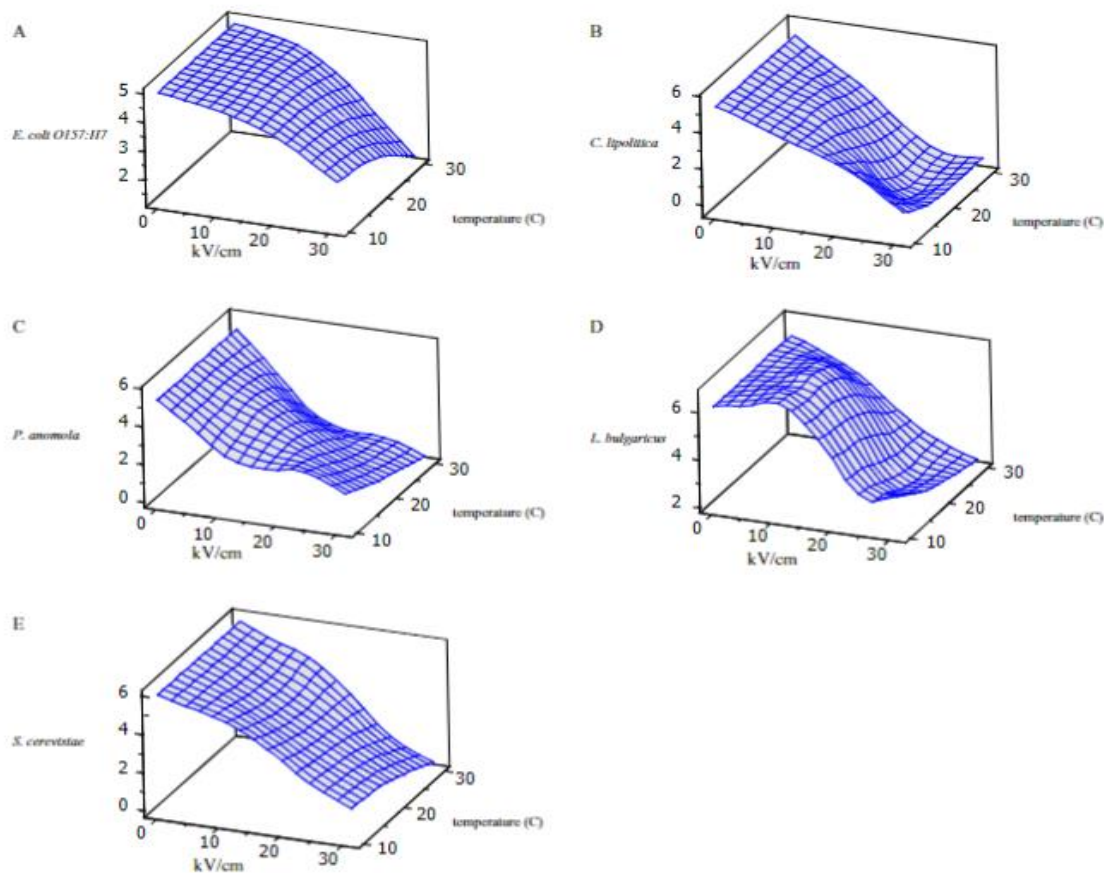

Figure 2.12 Inactivation of *E. coli* (A), *Candida lipolytica* (B), *H. anomala* (C), *Lactobacillus delbruekii* (D) and *Saccharomyces cerevisiae* (E) by pulsed electric fields as a function of electric field strength and treatment temperature (Abca & Evrendilek, 2014)

2.5.2 Application of PEF for wine decontamination after alcoholic fermentation

Although *S. cerevisiae* strains are usually predominant in wine at the end of AF, certain microorganisms, such as yeasts, lactic acid bacteria (LAB) and acetic acid bacteria (AAB) from grapes and winery facilities and environment can spoil the wine. After AF, some wines are also subjected to malolactic fermentation (MLF) and generally, LAB starter cultures are put in the wine to ensure a good implantation of these bacteria and prevent the proliferation of undesirable bacteria. The usual additions of SO₂ done in the previous steps can limit, or hamper, the implantation of the microorganism selected as starter. PEF could be an efficient technique capable of reducing the competitive pressure exerted, during MLF, on culture starters in freshly fermented wines (Delso *et al.*, 2021).

González-Arenzana *et al.*, (2015) experimented the efficacy of pulsed electric fields treatments on Tempranillo wine at 17, 21 and 23 kV/cm in the inactivation of 25 species of wine-related microbiotas. Levels of inactivation ranged from 1.70 to 3.04 log units for yeasts, from 1.01 to 4.16 for LAB and from 0.64 to 4.94 for AAB. Likewise, Abca & Evrendilek investigated the effectiveness of PEF against different microbial strains in red wine. A treatment at 31 kV/cm produced a reduction of more than 5.0 log cycles in *Hansenula anomala*, *Candida lipolytica* and

Saccharomyces cerevisiae yeast populations, and 3.6 and 4.0 log cycles in *Escherichia coli* and *Lactobacillus bulgaricus*, respectively.

Furthermore, according to the new consumer trend towards healthy products and overall reduction of alcohol intake, wines with lower alcohol content are being produced (Saliba *et al.*, 2013). Lower alcohol content means higher risk of proliferation and spoilage of wine by undesirable microorganisms. PEF treatments (40kV/cm) allowed to achieve inactivation levels up to 1.5 and 2.0 log cycles of LAB and yeasts respectively, in wines which had only 8.5% alcohol content (Puligundla *et al.*, 2018).

2.5.3 Application of PEF for wine decontamination after malolactic fermentation

After MLF, wine is usually racked and stored in stainless steel tank, waiting for the next step of vinification. PEF inactivation of LAB strains involved in this secondary fermentation has been studied by several authors, with similar results. Puertolàs *et al.*, (2009) found that *Lactobacillus hilgardii* and *Lactobacillus plantarum* displayed the highest resistance to the treatment. In another study, the most resistant strains to PEF treatment (23 kV/cm 49°C) were found out to be *Oenococcus oeni* and *Pediococcus pentosaceus*. González-Arenzana *et al.* (2019) detected that, after MLF, the application of PEF treatment (23 kV/cm) in combination with low sulphitation (15 mg/L), had similar or greater effectivity than a higher SO₂ addition (30 mg/L) in terms of microbial stabilization. Accordingly, PEF treatment alone or combined with SO₂ allowed to obtain a significant reduction in the overall population of yeasts, LAB and AAB.

2.5.4 Application of PEF for acceleration of yeast autolysis and aging on lees

Yeast autolysis is a lytic event promoted by yeast enzymes that are activated after cell death. This self-degradative process is important during aging on lees process. This technique has been mainly used for sparkling wines, and more recently extended to the production of white, and even red wines, and consists in maintaining the wine in contact with yeast lees for some time after fermentative processes (Maza *et al.*, 2020). During this period, yeasts lysis leads to the release of certain compounds such as nucleic acids, proteins, polysaccharides and lipids that influence physico-chemical and sensory properties of wine (Charpentier *et al.*, 2004). There is an interest in speeding up the process because prolonged wine aging on lees entails high labour costs, space occupation, microbial spoilage risks and production of unwanted metabolites, such as biogenic amines (González-Marco & Ancin-Azpilicueta, 2006).

Martinez *et al.* (2016) investigated on the possibility to use PEF for this purpose. In the study, it was demonstrated that the use of electric fields (5-25 kV, 30-240 μ s) triggered the autolysis of a *Saccharomyces* commercial strain. Autolysis was monitored by release of intracellular material into the extracellular environment. The application of PEF, causing electroporation of cell membranes, modifies the selective permeability of yeast cytoplasmic membranes, leading to the release of intracellular compounds in the extracellular medium, detected after only 24h. Later on, after 18 days of incubation, the concentration of mannoproteins in PEF treated wine was 10 times higher than in control. This effect has been associated with the release of certain enzymes, namely proteases and β -

glucanases, involved in cell-wall degradation. Cell electroporation causes a modification in the osmotic pressure of the cytoplasm, that leads to plasmolysis of organelles containing the above cited enzymes. The pores formed in cytoplasm favour the contact of these enzymes with mannoproteins (Figure 2.13)

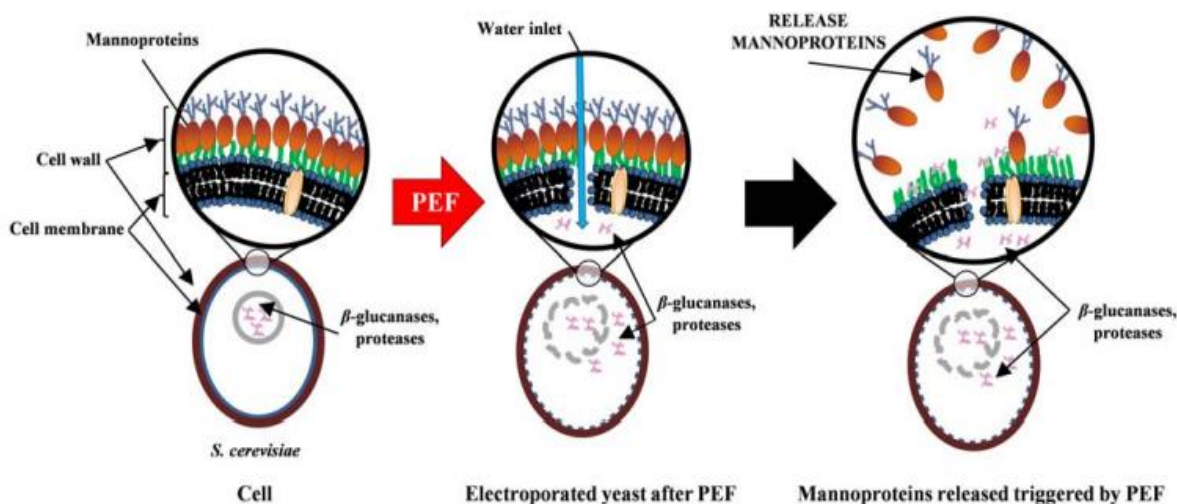

Figure 2.13 Mechanism of pulsed electric field triggering yeast autolysis (Delso et al., 2022)

The authors also investigated the influence of temperature (7°C-43°C), pH (3.5-7.0) and ethanol concentration (6%-25%) on the release of mannoproteins from yeast treated with PEF. The highest release took place with the most favourable condition for activity of enzymes (pH = 7.0, T = 43°C, Et[OH] = 6%).

2.5.5 Application of PEF for oak aged wine decontamination

Oak aging is one of key step in the production of high-quality wines, allowing to develop wine in terms of colour, aroma, taste and stability (Garde-Cerdán et al., 2006). Oak wood is a porous material, necessary for air exchange towards the external environment, to maintain a low oxidative condition inside the barrel during aging process. The problem consists in the difficulty in cleanliness and sanitation of the barrels. Therefore, they present an ideal environment for microbial proliferation, responsible for spoilage of wine (Stadler & Fischer, 2020). This is a relevant problem, especially in case of *Brettanomyces*, due to his negative impact on wine.

In a study, barrel aged preservative-free wine was treated with PEF, with high level of microorganisms reduction (González-Arenzana et al., 2019). However, after 5-9 months, the recovery of some of those species was observed, evidencing the need to conduct further studies regarding the effect of PEF, intensity of application and the evolution of microbial population during long storage periods.

3. Material and methods

3.1 Vinification of Moscatel table wine

Grapes of Moscatel Graúdo (or Moscatel de Setúbal), with the Portuguese cast code reference PRT 52311 were used to produce table white wine. One tonne of grape bunches was acquired from Quinta do Cerrado da Porta, in Sobral do Monte Agraço, Lisboa, with harvest time decided considering climatic factors and grape maturity parameters (Brix degree, Total acidity and pH). Grapes were hand-picked, put in 15 kg boxes and immediately taken to the pilot-scale lab/winery.

After reception, the batch was divided in two parts, by means of an industrial scale. Two fractions of grape clusters with similar weight were crushed/destemmed, being one of them the control conventionally extracted (CE), and the other one submitted to pulsed electric fields treatment for extraction, before vinification.

Table 3.1 Date of harvest and weight of grapes used as "control" (conventionally extracted) and "PEF1" treatment (pulsed electric fields aided extraction)

Code	Origin	Date of Harvest	Grape Sanity	Mass (Kg)
230921_MO_C	Quinta do Cerrado da Porta	23/09/2021	Optimal	518.06
230921_MO_PEF				503

The different batches were attributed with a code, considering the date of harvest/processing, variety used and the absence (230921_MO_C) or presence (230921_MO_PEF) of the PEF treatment.

The two batches were processed in the most identical way possible, to try to get the two products as similar as possible, except for the application of PEF treatment on one of the two batches. To start, grape boxes were directly emptied into the destemmer/crusher, where berries were separated from the stems and crushed. Then, juice and solid parts fell into the receiving hopper of the peristaltic pump. For the PEF treated batch (230921_MO_PEF) the heliflex hoses were linked to the peristaltic pump to the PEF treatment chamber (see Section 3.3.1) and lead the grape mass to the press (Bucher Vaslin Press XPro).. The treatment chamber only applies pulses of electric fields when required. For the control conventionally extracted, the same system was used but without application of PEF so that the peristaltic pump conveys the grape mass to the press.

During the process of pressing, only the first part ("lágrima"), obtained applying 1 bar for 20 minutes, was collected and used for vinification and further testing and analysis: 270 litres obtained for the control and 265.7 litres for

Table 3.2 Physico-chemical parameters of "CE" and "PEF1" treatment

Code	pH	Total Acidity (g/l)	% Prob. Alcohol	Density	Conductivity (mS/cm)	Turbidity (After pressing)
230921_MO_C	3.42	5.9	11.10%	1086	2.13	914
230921_MO_PEF	3.54	5	11.00%	1085	2.26	980

must obtained with PEF. Must samples (“lágrima”) were collected and analysed for physico-chemical parameters (Table 3.2)

After pressing, wine was moved to a tank and temperature lowered at 10°C for 48h, to favour a gravitational decantation of must. After a first rack, wine was inoculated with *Saccharomyces cerevisiae* (Fermol Complete Killer Fru – AEB Group), to allow a better control of fermentation and microbial fauna involved in alcoholic fermentation (AF) process. Yeast nutrients (Ammonium sulphate, Ammonium biphosphate and Thiamin-Hydrochlorid, Enovit – AEB Group) and SO₂ were added as well (Table 3.3). To favour fermentation and yeast growth, temperature was raised at 14-16°C, and yeast was inoculated. After AF, 5g/hL of SO₂ were added.

Table 3.3 Additions in CE (conventional extraction) and pulsed PEF (electric fields extracted) samples.

	SO ₂	LSA	ENOVIT
230921_MO_C	224.3 ml (24-Sep)	48g (25-Sep)	72g (25-Sep)
230921_MO_PEF	222.9 ml (24-sep)	49.5g (25-Sep)	72g (25-Sep)

3.2 Experimental design

PEF treatment was applied twice during the winemaking process. Before pressing (1), to increase the yield and extraction of phenolics from grapes, on 23/09/2021 (PEF1), and before bottling (2), on 26/07/2022, to stabilize the wine (PEF2) (Figure 3.1). Sensorial and physico-chemical analysis were performed to the four finished wines obtained: CE – conventionally extracted, PEF1- pulsed electric fields aided extraction, CE+PEF2 – conventionally extracted and PEF stabilized, PEF1 + PEF2 – pulsed electric fields aided extraction and PEF stabilization.

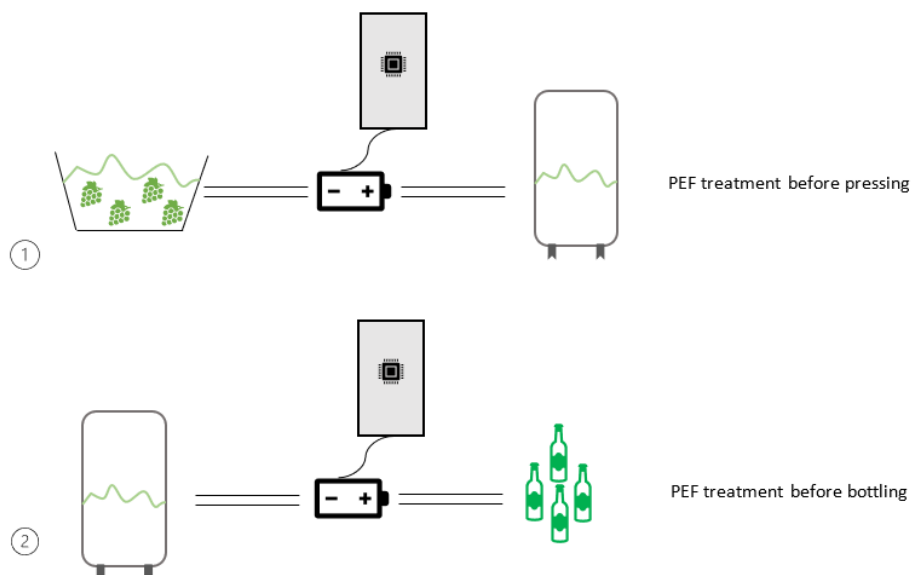

Figure 3.1 Experimental design of the pulsed electric fields (PEF) treatments applied on must (1) and finished wine (2).

Details on the PEF equipment and processing conditions, and physico chemical analysis are described in the following sections of material and methods. The physico chemical analysis were carried out in the end of July to the 4 wines. Three sessions of sensory triangle tests were carried out to assess colour and flavour (taste and smell) differences between 2 treatments at each time. Firstly, in May 2022, finished wines produced with 2 different methods of extraction were assessed (CE vs. PEF1). Then, in the end of July 2022, the wines were submitted to a PEF stabilization treatment and the following samples were compared: CE vs CE+PEF2 and PEF1 vs.PEF1+PEF2.

3.3 PEF treatments

The PEF generator used in both PEF treatments was the same, as this is the most expensive part of the PEF equipment (EPULSUS®-PM1A-10). It can generate bipolar pulses up to 10kV, 200 A and 3 kW and was designed and installed by EPS EnergyPulse Systems, Lda funded by the project PureWine of Portugal 2020. The technique used to generate pulses is a solid-state Marx generator (Redondo and Silva, 2009)

3.3.1 PEF aided juice extraction before pressing

One tonne of grape harvested and divided in two fractions. After the destemming/crushing phase, one of the two batch was subjected to PEF processing, in the industrial scale equipment described below (Figure 3.2).



Figure 3.2 Co-linear PEF treatment chamber used before pressing with vertical configuration.

The mash obtained after destemming crushing phase was pumped into the co-linear treatment chamber (DN50, 50 mm nominal pipe diameter and 50mm gap between electrodes) tangentially with respect to the applied electric field, by a rotary lobe pump, at flow rate of 4 tonnes/h. PEF treatment was conducted at an electric field strength of 8kV and specific energy 2kJ/kg, with bipolar pulses with a width of 50 μ s, and frequency of 100 Hz and measured current 50 A.

3.3.2 PEF stabilization treatment before bottling

In this PEF treatment, wine has been treated with pulsed electric fields with the aim to reduce the microbial load of the liquid. The flow rate of the wine was 200 L/h. The treatment chamber was also co-linear, DN10 (nominal diameter), 10mm gap between electrodes. The process parameters used were 10 kV, bipolar pulses with 150 Hz frequency and 25 μ s width. The measured current was 104 A. The electric field intensity was 10 kV/cm.

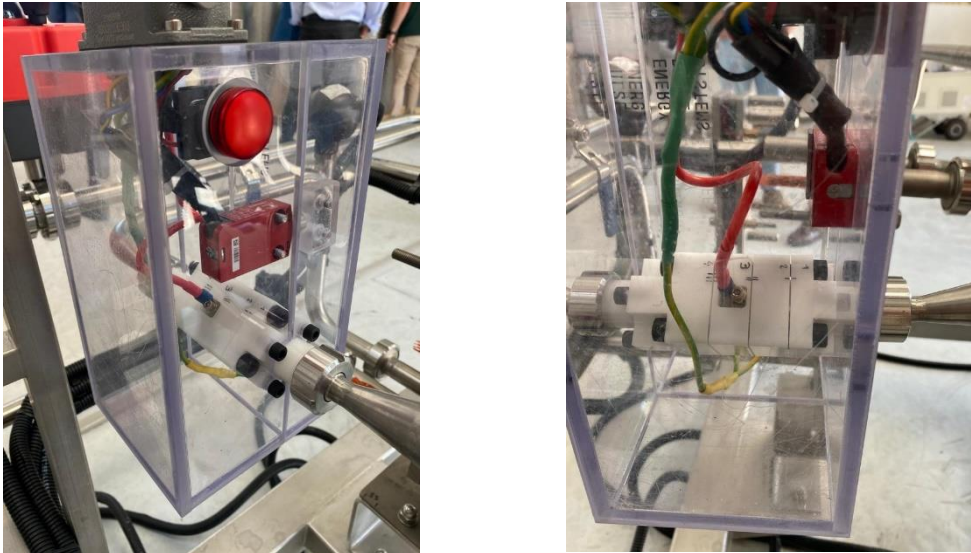

Figure 3.3 Photographs of PEF treatment chamber used for microbial inactivation, before bottling, for wine stabilization.

3.4 Sensory assessments

3.4.1 Wine sensory characterization

A sensory evaluation of the control and PEF treated wine was performed using a tasting sheet (“ficha auxiliar de prova”, in annex), as a guide. The two wines, control and PEF aided extracted, were tasted at a temperature around 8°C with the aim to characterize them and find out any possible differences derived by the PEF treatment. A visual exam, followed by a smell and taste examination were carried out with the aim to classify the wine, and detect any possible differences between the two samples.

3.4.2 Consumer triangular test for colour and overall flavour

A forced choice triangular test (*annex n. 1 and 2*) was selected to explore the potential differences among the wine produced with and without the help of PEF equipment. Three glasses of wine, two identical and a different one that could be either the PEF treated or not, were presented to 24 non trained panellists that were asked to try to detect differences in colour and then differences in odor-taste. Panellists had to select the different one.

The first set of wines to compare were PEF1 sample (PEF extraction of must) and wine produced with conventional extraction (CE) which has not undergone any treatment. The second triangular test was set to compare CE vs

CE+PEF2 (wine which underwent to PEF treatment just before bottling), and last set of triangular test compared PEF1 (PEF for must extraction) and PEF1+PEF2 (wine treated with PEF before pressing, and before bottling).

Then, χ^2 was calculated using the following equation (*Equation 3.1*):

$$\chi^2 = \left[\frac{(O - E)^2}{E} \right]_{\text{Correct}} + \left[\frac{(O - E)^2}{E} \right]_{\text{Incorrect}} \quad (3.1)$$

where O is the number of observed answers and E the number of expected answers (correct and incorrect). If χ^2 is lower than critical χ^2 (taken from χ^2 distribution chart for 0.05 value of significance), there is no significant difference between the two samples being tested.

In addition to the triangular test, the panellists were asked to answer a few questions about the wines, as the degree of difference between the samples (none, slight, moderate, great), which one they preferred (identical or odd samples) and if the wines were acceptable in terms of colour and taste. Also, a section for free comments was added, to give space to the panellists to express their thoughts about the tasted samples.

3.5 Physico-chemical analysis

The chemical analysis were performed at Ferreira Lapa laboratory (Enology Sector) of Instituto “Superior de Agronomia”. Different analysis have been performed, as listed below. All the measurements have been performed in triplicates in the end of July, just after PEF stabilization treatment.

3.5.1 Pressing yield

The juice extraction yield was evaluated in terms of the percent ratio between the weight of the juice obtained and that of the mash before pressing

3.5.2 Alcohol content

Ethanol (OIV-MA-AS2-01B) has a depressive effect on the boiling point of the wine, so the alcoholic content of wine can be evaluated as the temperature difference between the boiling point of wine and the boiling point of distilled water.

According to the OIV method, the boiling point of the water is first determined by filling the ebulliometer with distilled water, bringing it to the boiling point. This temperature is recorded as a temperature at 0.0% alcohol. The boiling chamber is filled with 50 ml of wine, to determine the boiling point of the wine sample, while the capacitor is filled with cold water (this prevents the evaporation of alcohol) and the solution is brought to boiling temperature. The ebulliometer has a thermometer and, once the temperature is stable, it is recorded. The alcoholic gradation of wine can be determined through an ebulliometer wheel. In the wheel, the boiling point of distilled water and wine sample are set according to the results obtained, and the wheel gives the alcoholic content of wine expressed in volume /volume.

3.5.3 pH and total acidity

-pH (OIV-MA-AS313-15) is a measure of acids found in wine (e.g. tartaric acid), expressed the difference in potential between two electrodes immersed in a liquid. pH has an impact on taste, aroma of wine and its stability, evolution and protection. A pH-meter can be used to measure pH in grape must and wine. The pH-meter calculates the activity of hydrogen ions in pH units by measuring the difference in electrical potential between a pH electrode and an electrode reference connected to a power meter. Low pH values correspond to a higher concentration of these free anions.

-Total acidity (OIV-MA-AS313-01) is defined by the OIV as the sum of titratable acids up to pH 7.0 without considering SO₂ and CO₂. (OIV, 2016). Following the OIV method, 50 ml of wine was placed in a under vacuum flask. The vacuum was applied using a water pump while it was being continuously shaken to eliminate carbon dioxide. In a becker, 25 ml of boiled water, 1 ml of bromothymol blue solution (indicator of titration) and 5 ml of wine were combined. For the titration 0.1 mol/L sodium hydroxide solution was added until the colour changed to blue - green.

3.5.4 TPI (total polyphenol index)

Total phenols (Riberau-Gayon, 1970) can be divided into two categories: flavonoids and non-flavonoids, which are a large group of different chemical compounds that influence taste, colour and mouth sensation.

Total phenols, flavonoids and non-flavonoid values are detected in absorbance units (Abs), and converted in mg/l of gallic acid according to this equation (*Equation 3.3*):

$$\text{TPI (mg/l)} = ((\text{Abs} \times 10) + 0,034) / 0,0395 \quad (3.3)$$

TPI can be estimated through Somers and Evans method (1977), following the procedure described below:

1st step: dilution of 1mL of wine with water, in a 100mL flask.

2nd step: measure of absorbance of the solution at 280nm in 10mm cell cuvette by spectrophotometer

3.5.5 Flavonoids and non-flavonoids

The Kramling and Singleton method (1969) allows to obtain an estimate of non-flavonoids. The procedure is described below:

1st step: 10mL are mixed, in a tube, with 10mL of HCl 1:4 concentration

2nd step: addition of 5mL of formaldehyde standard solution

3rd step: test tube is spread with nitrogen and plugged

4th step: wait 72h, and then measure the absorbance using spectrophotometer

This method is based on the measurement, at 280nm, of the absorbance of the sample after the precipitation of flavonoids compounds, through a reaction with formaldehyde under specific conditions, at room temperature and low pH.

As reported above, the non-flavonoids content can be evaluated using a calculation, from absorbance units to mg/l of gallic acid, as follow (*Equation 3.3*):

$$\text{Non flavonoids (mg/l)} = ((\text{Abs} \times 10) + 0,034) / 0,0395 \quad (3.3)$$

The amount of flavonoids, when results of TPI and non-flavonoids are obtained, can be calculated as the difference between the total phenols, and non-flavonoids, as follow (*Equation 3.4*):

$$\text{Flavonoids (mg/l)} = \text{Total phenols} - \text{non flavonoids} \quad (3.4)$$

3.5.6 Turbidity

Turbidity (OIV-MA-AS2-08) is a reduction of the transparency of a liquid due to the presence of undissolved substances, being a highly relevant factor for the evaluation of wine. Turbidity represents a quality parameter that influences consumer choice and, so, it should be kept in account when producing wine. Turbidity is measured according to the NTU (nephelometric turbidity units) values, with higher values in more turbid wines. This parameter is influenced by several aspects, such as different winemaking techniques. Typically, young wines have a turbidity with values greater than 200 NTU, while more stable wines have a lower NTU value, usually less than 100 NTU.

Turbidity is measured in the turbidimeter, using the scattering of light at 90° in relation to the direction of the incident beam. This parameter is measured in NTU. In order for the results to be concrete and real, they must be calibrated with standard solutions.

Table 3.4. Correspondence between turbidity measurement (NTU) and appearance (adapted by Ribereau-Gayon et al., 2006)

	Brilliant	Turbid
White wine	<1.1	>4.4
Rosè wine	<1.4	>5.8
Red wine	<2.0	>8.0

3.5.7 Colour intensity and CIELab analysis

- Colour intensity (OIV-MA-AS2-07B: R2009, Type IV method) values are obtained by measuring the absorbance of a wine sample (previously centrifuged) at 420 nm using a spectrophotometer (Agilent technologies, Cary series UV-Vis spectrophotometer). In our case, though as we analyzed a white wine, the value taken in account was just the 420 nm, giving the following equation (*Equation 3.5*):

$$IC(u.a.) = A420 \quad (3.5)$$

Where: A420 = absorbance at 420 nm of the wine;

- CIE Lab method (OIV- MA-AS2-11) is a spectrophotometric method that defines the chromatic characteristics of wines and other beverages resulting from the trichromatic components: X, Y and Z, according to the International Commission on Lighting, attempting to imitate real observers in their colour sensations. The colour of a wine can be described using the following attributes: tonality, luminosity and chromatism.

This analytic method starts clarifying the wine by centrifugation at 3500 rpm for ten minutes, then a measurement of absorbance in a range between 380 and 780 nm is performed. The equipment is composed by a spectrophotometer (Agilent technologies, Cary series UV-Vis spectrophotometer) and a computer with a suitable programme able to calculate the coordinates (L^* , a^* and b^*). The chromatic characteristics of a wine are defined by the colorimetric coordinates cited above: clarity (L^*), red/green colour component (a^*) and blue/yellow colour component (b^*). In the spectrophotometer, two cuvettes are inserted: one containing the sample, and the other with distilled water, representing the control. The analysis has been performed in triplicates.

3.5.8 Statistical analysis

One way analysis of variance (ANOVA) was performed for each quality parameter analysed using Excel statistical software. The results for each wine sample (treatment) were expressed as means \pm standard deviation of triplicates. After ANOVA, for those treatments presenting significant differences in a specific quality parameter, a Tukey test was conducted to separate the parameter mean values of each treatment, using different alphabet letters to differentiate statistically different means.

4. Results and discussion

In this thesis, PEF is assessed as a cell disruption method to improve the yield and phenolic compounds extraction in must, and stabilize wine before bottling. To attain this, a study was conducted to evaluate the ability of PEF in two different moments of winemaking process, to perform the above-cited activities, while preserving the natural composition of wine and without any possible deterioration or spoilage. This study comprised two phases. The first one, with analysis performed with wine produced with PEF assisted extracted grape juice (before pressing, PEF1), while in the second phase, the finished wines extracted with the conventional (CE) and PEF methods (PEF1) were submitted to a PEF stabilization treatment (PEF2), just before bottling .

Sensorial and physico-chemical analysis were conducted on the four wine samples (CE, PEF1, CE+PEF2,PEF1+PEF2) to detect any possible effect of PEF treatments on various wine quality parameters as described in Material and Methods section.

4.1 Sensory characterization of wines

The two wines obtained, conventional (CE) and PEF extracted (PEF1), were submitted to a complete sensory evaluation, and compared. The visual exam revealed a citrine yellow colour, very similar in the two samples, limpid, without relevant particles, even if a slightly higher turbidity in wine produced with PEF assisted extraction of must. From the olfactory exam, the wine resulted with sufficient quality, and high intensity and persistency, in line with what could be expected from Moscatel variety. General characters were associated with floral, fruity and varietal aromas,. More precisely, some jasmine, litchi and pineapple smell attributes were present. By a tasting point of view, four main parameters were taken into account, namely sweetness, alcoholicity, body and acidity. Wine resulted soft sweet, light-bodied with high acidity, while alcohol was not so perceptible. All in all, it appeared balanced and quite pleasant. Retro-nasal aromas were sufficient, intense and persistent. In sum, the wines resulted very similar, except for a reduced off-flavour in wine not treated with PEF. However, this defect could not be directly associated with the treatment.

4.2 Triangular test

4.2.1 Colour and taste evaluation of wines from CE and PEF treated must before pressing

4.2.1.1 Colour evaluation

Results by 24 panellists are reported in the Table 4.1:

Table 4.1 Results of triangle test, to compare overall colour of treated (PEF extraction) and non-treated wine (conventional extraction). The expected number of right answers is 8 (n/3) and 16 (2n/3) for wrong ones.

CONTROL VS PEF1	CORRECT ANSWERS	WRONG ANSWERS	TOTAL
COLOUR (observed)	9	15	24
COLOUR (expected)	8	16	24

The calculated χ^2 value for colour is (Equation 4.1):

$$\chi^2 = \left[\frac{(9 - 8)^2}{8} \right] + \left[\frac{(15 - 16)^2}{16} \right] = 0.1875$$

As $\chi^2_{(\alpha=0.05)} = 3.84$, and χ^2 calculated is 0.1875, it is statistically proven that there is no significant difference between PEF extraction (PEF1) and non-PEF (CE) wine samples. More in detail, the major part of the participants found the difference negligible (52%) or slight (38%), while a small part (10%) found it moderate. Furthermore, those who chose the right sample found the difference slight in 62% of cases, moderate in 13%, while 25% of panellists found no differences between wine treated with PEF before pressing, and wine without PEF extraction application (Figure 4.1). According to the results, just one third of panellists was able to detect the right sample, evidencing almost no difference between the two samples. Furthermore, relevant comments from those who chose the right

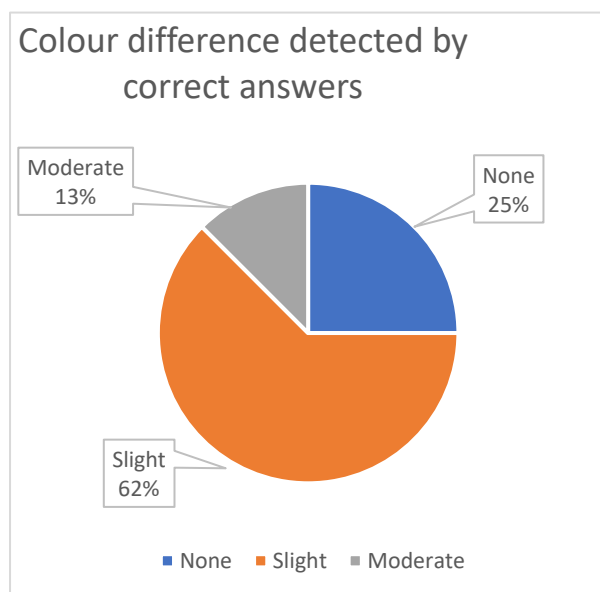

Figure 4.1. Percentage of panellists with right choice who classified the degree of colour difference between the two samples (CE and PEF) as slight, none and moderate

sample were related to the difficulty in the choice, because the samples looked extremely identical. These results showed no relevant, or slight difference between the two samples, as reported by the choice of panellists. However, a slight preference for CE sample was found.

4.2.1.2 Taste evaluation

Results by 24 panellists is reported in the Table 4.2:

Table 4.2 Results of triangle test, to compare overall smell and taste (flavour) of treated (PEF extraction) and non-treated wine (conventional extraction).

CONTROL VS PEF1	CORRECT ANSWERS	WRONG ANSWERS	TOTAL
TASTE (observed)	10	14	24
TASTE (expected)	8	16	24

The calculated χ^2 value for taste is (Equation 4.1):

$$\chi^2 = \left[\frac{(10 - 8)^2}{8} \right] + \left[\frac{(14 - 16)^2}{16} \right] = 0.750$$

As $\chi^2_{(\alpha=0.05)} = 3.84$, and χ^2 calculated is a lower value of 0.750, it is statistically proven that there is no significant difference between PEF extracted (PEF1) and non-PEF conventionally extracted (CE) wine samples. More in detail, most of the panellists found a slight difference (50%), or moderate (22%). A minority of the panellists ticked the box with none (18%) or great (9%). However, in many cases they were not able to identify the different sample, although they were forced to make a choice, even if random. Furthermore, those who chose the right sample found the difference slight in 66% of cases, moderate in 11%, while 23% of panellists found no differences between wine treated with PEF before pressing, and wine without PEF application. Similar to colour triangle test assessment, panellists had difficulty in choosing the right sample, even if the 66% of panellists who chose correctly, underlined a slight difference in terms of smell and taste. For flavour test panellists were also asked about wine preference. Panellists expressed a preference for PEF treated wine, but without any additional comment.

4.2.2 Colour and taste evaluation of conventionally extracted wine (CE) and CE submitted to PEF before bottling (PEF2)

To differentiate the two PEF treatments applied, PEF2 notation will be used for the second PEF treatment applied to the finished wine at the end of the processing line for stabilization before bottling.

4.2.2.1 Colour evaluation (CE vs CE+PEF2)

Results by 24 panellists is reported in the Table 4.3:

Table 4.3 Results of triangle test, to compare the overall colour between non-treated (CE) wine PEF stabilized wine (CE+PEF2).

CONTROL VS CONTROL+PEF2	CORRECT ANSWERS	WRONG ANSWERS	TOTAL
COLOUR (observed)	10	14	24
COLOUR (expected)	8	16	24

The calculated χ^2 value for colour is (Equation 4.1):

$$\chi^2 = \left[\frac{(10 - 8)^2}{8} \right] + \left[\frac{(14 - 16)^2}{16} \right] = 0.750$$

As $\chi^2_{(\alpha=0.05)} = 3.84$, and χ^2 calculated is 0.750, it is statistically proven that there is no significant difference in colour between PEF and non-PEF processed wine samples. More in detail, the highest part of panellists found a slight difference (58%), or none (21%). A lower part marked it as moderate (12%) or great (9%). However, in many cases they were not able to identify the different sample. Furthermore, those who chose the right sample found the difference slight in 50% of cases, moderate in 20%, while 30% of panellists found no differences between wine treated with PEF for wine stabilization (CE+PEF2), and wine without PEF application (CE). As for the first samples analysed, it seemed like the second PEF treatment applied, for wine stabilization, did not influence the colour of the treated sample, making panellists not able to select the different sample among them.

4.2.2.2 Taste evaluation (CE vs CE+PEF2)

Results by 24 panelists is reported in Table 4.4:

Table 4.4 Results of triangle test, to compare verify the taste differences between non-treated (CE) wine and PEF stabilized wine (CE+PEF2).

CONTROL VS CONTROL+PEF2	CORRECT ANSWERS	WRONG ANSWERS	TOTAL
TASTE (observed)	10	14	24
TASTE (expected)	8	16	24

The calculated χ^2 value for taste is (Equation 4.1):

$$\chi^2 = \left[\frac{(10 - 8)^2}{8} \right] + \left[\frac{(14 - 16)^2}{16} \right] = 0.750$$

As $\chi^2_{(\alpha=0.05)} = 3.84$, and χ^2 calculated is 0.750, it is statistically proven that there is no significant difference in taste between PEF (CE+PEF2) and non-PEF (CE) processed wine samples. More in detail, the highest part of panellists found a slight difference (33%), or moderate (38%). A lower part marked it as great (25%) or none (4%). However, in many cases they were not able to identify the different sample. Furthermore, those who chose the right sample found the difference slight in 22% of cases, moderate in 22%, while 55% of panellists found no differences between wine treated with PEF for wine stabilization (CE+PEF2), and wine without PEF application (CE).

4.2.3 Colour and taste evaluation of wines from PEF extracted must (PEF1) and PEF treated before botting (PEF1+PEF2)

4.2.3.1 Colour evaluation (PEF1 vs PEF1+PEF2)

As wine produced from PEF extracted must (PEF1) was also treated by PEF (PEF2) before bottling, a comparison of these two wine samples was also carried out, similar to previous section. Results by 24 panellists are reported in Table 4.5.

Table 4.5 Results of triangle test, to compare colour of wine from PEF extraction before pressing (PEF1) and the same wine PEF treated before bottling (PEF1+PEF2).

PEF1 VS PEF1+PEF2	CORRECT ANSWERS	WRONG ANSWERS	TOTAL
COLOUR (observed)	10	14	24
COLOUR (expected)	8	16	24

The calculated χ^2 value for colour is (Equation 4.1):

$$\chi^2 = \left[\frac{(10 - 8)^2}{8} \right] + \left[\frac{(14 - 16)^2}{16} \right] = 0.750$$

As $\chi^2_{(\alpha=0.05)} = 3.84$, and χ^2 calculated is 0.750, it is statistically proven that there is no significant difference in colour between PEF processed before and after stabilization. More in detail, the highest part of panellists found none (37%), or slight difference (33%). A lower part marked it as moderate (17%) or great (13%). However, in many cases they were not able to identify the different sample. Furthermore, those who chose the right sample found the difference slight in 33% of cases, moderate in 33%, while the rest of panellists found a great differences between wine treated with PEF for wine stabilization (PEF1+PEF2), and wine with PEF application just in extraction (PEF1).

4.2.3.2 Taste evaluation (PEF1 vs PEF1+PEF2)

Taste triangle test results by 24 panellists is reported in Table 4.6.

Table 4.6 Results of tringle test, to verify the taste differences between wine treated just before pressing (PEF1) and wine treated twice, before pressing and before bottling (PEF1+PEF2) wine.

PEF1 VS PEF1+PEF2	CORRECT ANSWERS	WRONG ANSWERS	TOTAL
TASTE (observed)	9	15	24
TASTE (expected)	8	16	24

The calculated χ^2 value for taste is (Equation 4.1):

$$\chi^2 = \left[\frac{(9 - 8)^2}{8} \right] + \left[\frac{(15 - 16)^2}{16} \right] = 0.1875$$

As $\chi^2_{(\alpha=0.05)} = 3.84$, and χ^2 calculated is 0.1875, it is statistically proven that there is no significant difference in taste between wine processed with PEF in both extraction and stabilization (PEF1+PEF2), and PEF processed samples for extraction (PEF1). More in detail, the highest part of panellists found slight (45%), or moderate difference (37%). A lower part marked it as great (13%) or none (4%). However, in many cases they were not able to identify the different sample. Furthermore, those who chose the right sample found the difference slight in 33% of cases, moderate in 55%, while the 11% of panellists found a great differences between PEF1 and PEF1+PEF2 treated wines.

In conclusion, these triangular tests showed a non-perceptible difference among the wines produced with/without or with a partial use of PEF processing. Panellists had issues selecting the right sample, thus underlining the small influence the treatment exerted on the wines. In agreement with these results, Comuzzo et al., (2018), analysing the aroma composition of Garganega cv. wine, reported an overall increase of varietal precursors. However, these values always remained above the odour threshold. This confirms the possibility to apply PEF in extraction, to increase the process yield, as no sensorial parameters has changed, and in extraction as well, to try to reduce the use of SO₂.

4.3 Physico-chemical properties of the wine and pressing yield of grape juice

PEF treatments did not affect the kinetics of alcoholic fermentation. The evolution of specific gravity during fermentation was comparable in the untreated (CE) and PEF-processed samples. In all cases, alcoholic fermentation was completed in ten days, with negligible levels of residual sugars.

4.3.1 Pressing yield

The PEF treatment produced an appreciable increase in the pressing yield of grape juice, from 57.90% to 64.75% for the sample PEF treated at 1.6kV/cm, 2kJ/kg specific energy, with an increase of 6.85 percentage points (Table 4.7). This increase represents a profit of 11.8% in final wine production from the same batch of grapes, and is in agreement with other studies (Comuzzo et al. 2018, Vorobiev & Lebovka, 2012). Comuzzo reported a yield increase of 8.9 and 4.3% for different PEF intensities.

Table 4.7 Yield difference between PEF treated (230921_MO_PEF) and non-treated (230921_MO_C) samples

Code	Weight (Kg)	Vol. Saignéé (L)	%	Vol. Press (L)	%	Total %
230921_MO_C	518.06	270	52.12	30	5.7	57.90
230921_MO_PEF	503	265.7	52.68	60	11.93	64.75

4.3.2 Alcohol content

The application of PEF extraction treatment did not affect the ethanol content of wine. As reported in literature review, no correlation between the application of PEF and ethanol content increase was found (Table 4.8). In fact, even if pulsed electric fields are used to desegregate cell membranes and favour juice extraction from berries, the amount of sugars present in the pulps and extracted is not influenced by the treatment (Comuzzo et al., 2018) and so, the alcoholic strength is not influenced. However, after PEF stabilization treatment analysis, alcohol content was lower.

Table 4.8 Alcoholic strength (v/v) of different wine samples. CE conventional extraction, PEF1 PEF extraction, CE+PEF2 conventional extraction + PEF stabilization treatment, PEF1+PEF2 PEF extraction and stabilization treatments (Results are means \pm Standard Deviations of triplicates, different letters indicate significantly different values according Tukey test)

alcoholic strength (% v/v)	
mean \pm SD	
CE	12.13 \pm 0.06 a
PEF1	12.13 \pm 0.06 a
CE+PEF2	11.73 \pm 0.06 b
PEF1+PEF2	11.70 \pm 0.00 b

4.3.3 pH and total acidity

- pH was slightly higher in the wine produced from PEF extracted grape juice (PEF1) (Table 4.9), and was not affected with PEF stabilization treatment (PEF2). In fact, the mean of CE sample was 3.44, and remained 3.44 after PEF treatment for wine stabilization. The same happened for PEF1 and PEF1+PEF2 wine samples. This increase in pH from CE to PEF1 might be explained by a higher degree of salification of organic acids, responsible for pH value (Comuzzo et al., 2018). Thus, due to the enhanced extraction of cations from grape skins, responsible for the creation of bounds with the above cited acids.

Table 4.9 pH values of the different samples. CE conventional extraction, PEF1 PEF extraction, CE+PEF2 conventional extraction + PEF stabilization treatment, PEF1+PEF2 PEF extraction and stabilization treatments (Results are means \pm Standard Deviations of triplicates, different letters indicate significantly different values according Tukey test)

pH	
mean \pm SD	
CE	3.44 \pm 0.00 b
PEF1	3.48 \pm 0.01 a
CE+PEF2	3.44 \pm 0.00 b
PEF1+PEF2	3.44 \pm 0.01a

The same trend was observed for total acidity, lower in wine with PEF application (5.30 g/L of tartaric acid) than in control (5.41 g/L), for the same process explained fort pH. However, this minor decrease in total acidity is not registered for PEF stabilized wines which presented the same total acidity (Table 4.10).

Table 4.10 Total acidity results (g/L tartaric acid) of different samples. CE, conventional extraction PEF1, PEF extraction CE+PEF2, conventional extraction + PEF stabilization treatment - PEF1+PEF2, PEF extraction + PEF stabilization treatment. (Results are means \pm Standard Deviations of triplicates, for each column different letters indicate significantly different values according Tukey test)

Total acidity (g tartaric acid/L)	
mean \pm SD	
CE	5.41 \pm 0.085 ab
PEF1	5.30 \pm 0.02 b
CE+PEF2	5.53 \pm 0.040 a
PEF1+PEF2	5.53 \pm 0.02 a

4.3.4 Total phenols, flavonoids and non-flavonoids

One of the main reasons why PEF is being studied for an application in the winemaking process, is the possibility to increase the extraction of chemical compounds, such as phenols, from grape skins. As reported in Literature review section, there are several studies reporting a positive correlation between PEF application during extraction and the increase of phenolics content in must and, consequently, wine. However, due to their major role in the red winemaking process, especially for wine colour and structure development, most of those studies are addressed to the production of red wines, while just a few of them involve the production of white wines.

Table 4.11 Total phenols, non-flavonoids and flavonoids contents of different wine samples. CE conventional extraction, PEF1 PEF extraction, CE+PEF2 conventional extraction + PEF stabilization treatment, PEF1+PEF2 PEF extraction and stabilization treatments (Results are means \pm Standard Deviations of triplicates, for each column different letters indicate significantly different values according Tukey test).

	Total phenols (mg/L)	Flavonoids (mg/L)	Non-flavonoids (mg/L)
	mean \pm SD	mean \pm SD	mean \pm SD
CE	254.48 \pm 2.78 b	155.35 \pm 3.52 b	99.12 \pm 1.59 b
PEF1	257.02 \pm 0.35 b	155.88 \pm 0.18 b	101.14 \pm 0.45 b
CE+PEF2	215.86 \pm 0.66 a	130.52 \pm 1.09 a	85.18 \pm 0.90 a
PEF1+PEF2	217.79 \pm 2.33 a	132.61 \pm 1.79 a	85.34 \pm 0.86 a

However, results from this study (Table 4.11) evidenced a similar extraction of total phenols in CE and PEF1 wines (Figure 4.2). The difference in phenolics extraction between conventional extraction procedure, and PEF application, was negligible. The same happened in the two subclasses analysed, flavonoids and non-flavonoids. A reason for this equality of extraction, that differs from literature results, could be attributed to the necessity, for a higher extraction of these compounds, of a period of maceration. The application of PEF, producing a desegregation of membranes, could produce bounds in grape berries skins, inducing a better release of these compounds. However, the limited time of skins in contact with must, did not allow this process. In fact, in the winemaking process of this Moscatel, grapes, after PEF application, were immediately submitted to pressing. The second application of pulsed electric fields, just before bottling, caused a significant decrease in the total phenols in both wine samples. The difference in the amount of phenols should be related to different chemical processes that happen in wine during storage in tank until July, the time when PEF2 was applied. Those chemical processes possibly lead to a precipitation of part of these molecules and absorption on yeast membranes. Similar trends were observed for flavonoids and non-flavonoids.

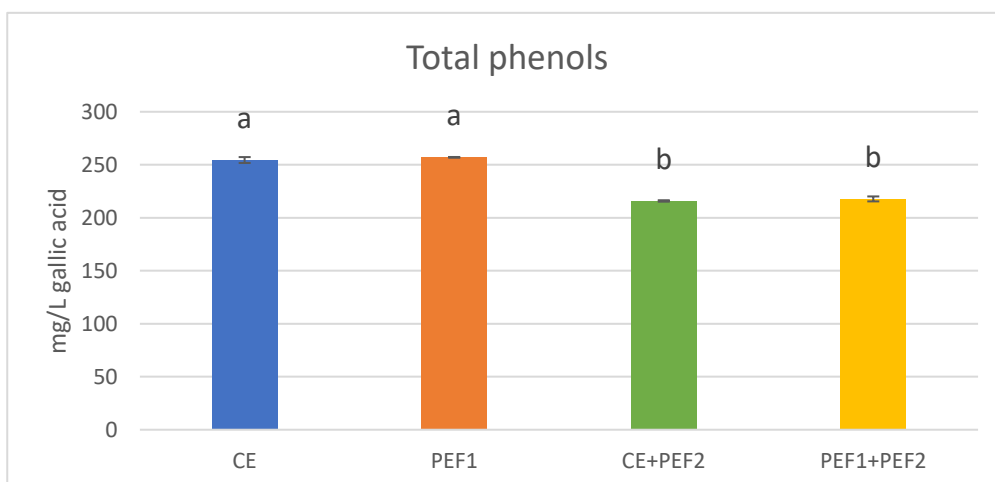

Figure 4.2 Total phenols content of different wine samples. CE conventional extraction, PEF1 PEF extraction, CE+PEF2 conventional extraction + PEF stabilization treatment, PEF1+PEF2 PEF extraction + PEF stabilization treatments (values are sample averages, and error bars are standard deviations; different letters indicate significantly different values according Tukey test)

4.3.5 Turbidity

The wine submitted to PEF stabilization in July 2022 was kept in two vats in the pilot scale winery, and it was noticed as very turbid, even before being treated with PEF2. Therefore, PEF2 samples should be analysed independently from the other two samples which were stored in the bottles since May 2022. As shown in Figure 4.3, PEF extraction treatment caused a significant increase in wine turbidity from 4.9 to 9.0 NTU. On the contrary, with respect to the two the samples submitted to PEF stabilization, the PEF1 wine presented a lower turbidity (60 NTU) than the CE wine (70 NTU).

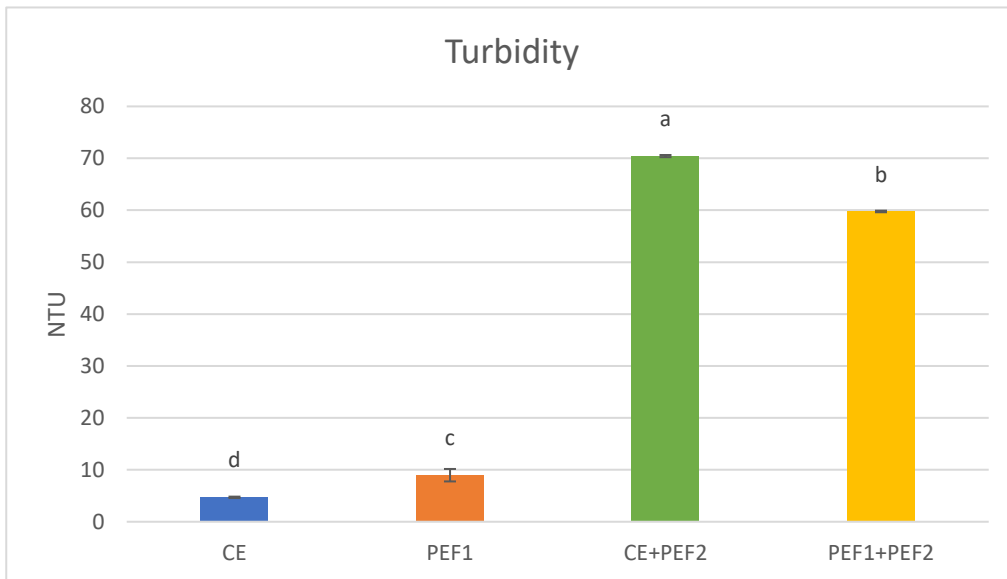

Figure 4.3 Turbidity level (NTU) of different wine samples. CE conventional extraction, PEF1 PEF extraction, CE+PEF2 conventional extraction + PEF stabilization treatment, PEF1+PEF2 PEF extraction + PEF stabilization treatments (values are sample averages, and error bars are standard deviations; different letters indicate significantly different values according Tukey test)

4.3.6 Colour intensity and CIELab colour parameters

As expected from literature results, PEF was able to produce a wine with a more intense yellow colour (even if non detectable by the panellists, as demonstrated by triangular test). As shown in Figure 4.4, and confirmed by Tuckey test conducted, there was a relevant difference between conventional and PEF extracted wines. In particular, PEF extracted wine had a higher absorbance value than CE. The increased absorbance at 420nm could be attributed to the skin cells desegregation caused by PEF extraction treatment. The PEF stabilization treatment increased significantly the absorbance of both samples (CE and PEF1).

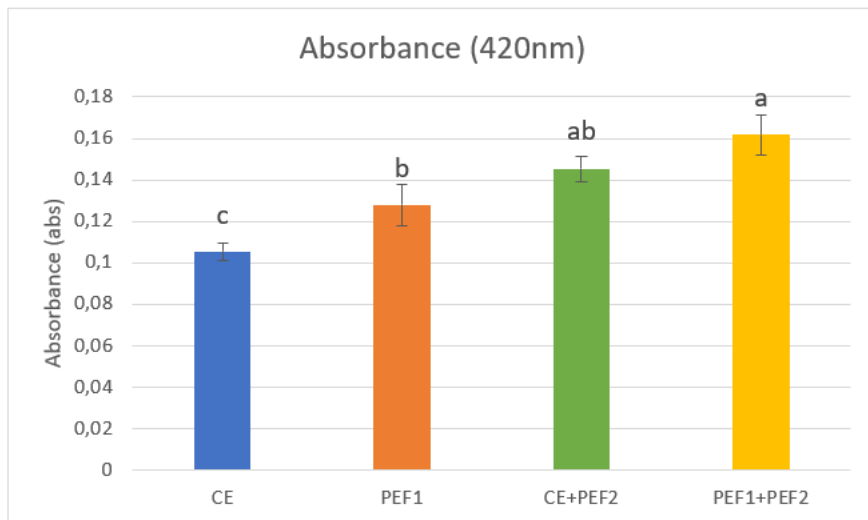

Figure 4.4 Absorbance values (abs) of different samples. CE, conventional extraction PEF1, PEF extraction CE+PEF2, conventional extraction + PEF stabilization treatment - PEF1+PEF2, PEF extraction + PEF stabilization treatment. (values are averages of triplicates, and error bars are standard deviations; means with different letters are significantly different according to Tukey test)

With respect to CIELab, L* indicates brightness or lightness, varying in value between 0, which indicates black, or minimum brightness, and 100 which relates to white, or maximum brightness. CE sample presented a higher lightness (closer to transparent) than the other 3 wine samples (PEF1 extracted, PEF2), which presented similar a similar L* value (Figure 4.5).

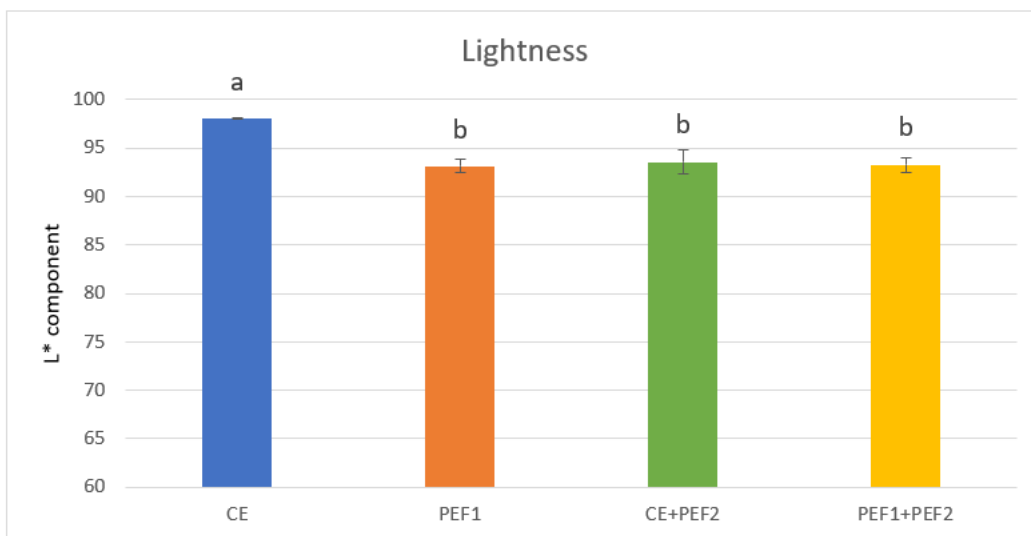

Figure 4.5 L* CIE value of different wine samples: CE conventional extraction, PEF1 PEF extraction, CE+PEF2 conventional extraction + PEF stabilization treatment, PEF1+PEF22 PEF extraction + PEF stabilization treatments (values are averages of triplicates, and error bars are standard deviations; means with different letters are significantly different according to Tukey test).

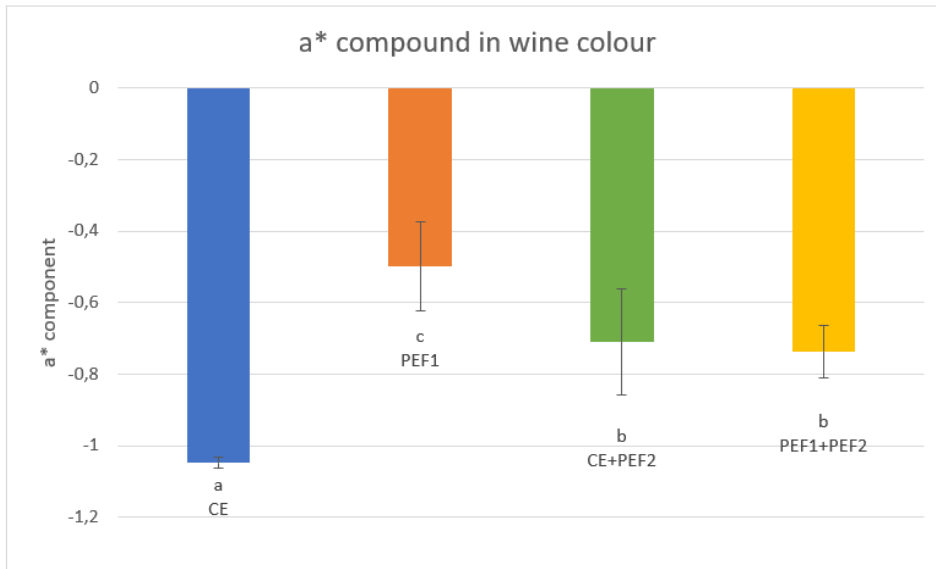

Figure 4.6 a* CIE colour of different wine samples: CE conventional extraction, PEF1 PEF extraction, CE+PEF2 conventional extraction + PEF stabilization treatment, PEF1+PEF22 PEF extraction + PEF stabilization treatments (values are averages of triplicates, and error bars are standard deviations; means with different letters are significantly different according to Tukey test).

Regarding a* and b*, the colour components, a* value was negative, but close to zero, for all the samples, indicating a colour towards light green (Figure 4.6). The PEF1 sample presented the lowest value of a*, followed by both PEF2 samples and lastly CE wine sample, which presented the lowest a*. b* value had a positive value for all the samples, indicating a colour towards light yellow. CE had a lower b* than the other 3 samples, which presented a similar b* value (Figure 4.7). Thus, the difference between CE and PEF1 samples disappeared in wine after PEF stabilization treatment. In conclusion, all the samples showed values close to zero for a* and positive values for b*, which means that all of them, to a greater or lesser extent, have a yellow-greenish colour.

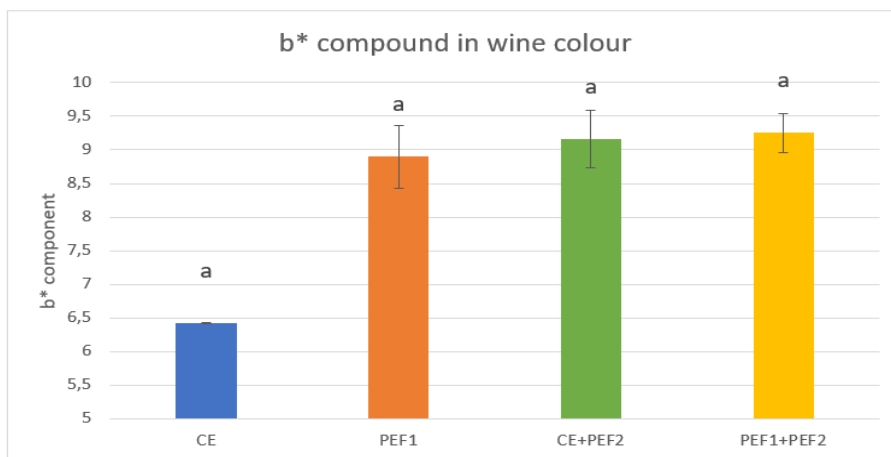

Figure 4.7 b* CIE colour of different wine samples: CE conventional extraction, PEF1 PEF extraction, CE+PEF2 conventional extraction + PEF stabilization treatment, PEF1+PEF22 PEF extraction + PEF stabilization treatments (values are averages of triplicates, and error bars are standard deviations; means with different letters are significantly different according to Tukey test).

5. Conclusions

The aim of the present study is to investigate the effect of PEF treatment on the quality of table white wine Moscatel de Setúbal variety. In general, the triangle tests carried out for colour, smell and flavour of the 4 wines revealed there is not a significant difference between wine samples submitted to PEF treatment and controls, with all wines classified as acceptable by the panellists. The following conclusions were taken regarding each objective initially proposed:

- to compare a wine produced from grape juice conventionally extracted (CE) to one produced from pulsed electric fields assisted extraction (PEF1), in which extraction was helped by using pulsed electric fields, to increase the yield and extraction of different substances from grape berries. The sensorial exam evidence a citrine yellow colour, very similar in the two samples, with a slight higher turbidity in wine produced with PEF treatment. From olfactory exam, the two samples resulted similar, with high intensity and persistency. By tasting, the wine resulted also similar, with a great freshness and acidity. According to triangular test results carried out with 24 non-trained panellists, but used to drink wine, the samples were not different in terms of overall colour, smell and taste. A slight preference for PEF treated wine was observed. Regarding physico-chemical parameters, an increase of 6.85% in the juice yield was registered for PEF extracted grape juice, associated with an increase in absorbance of yellow (at 420nm). The level of phenolics in wine, that was expected to be higher in wine produced from PEF extracted grape juice, did not change. CIE Lab results showed a slight difference between CE and PEF1 treated wines, in which CE had higher L* and a* value, and a lower b* value than PEF extracted wine sample. A higher level of turbidity was registered in PEF treated sample.
- to apply PEF before bottling to stabilize wine and assess sensory and physico-chemical quality. According to triangular test results, comparing CE and CE+PEF2 samples, panellists were not able to detect differences in the overall colour and smell/taste of the 2 wine samples. Similar result was obtained with exclusively PEF extracted sample (PEF1) and PEF extracted and stabilized sample (PEF1+PEF2). The application of PEF stabilization treatment to the finished wine before bottling did not affect wine sensorial and physico-chemical quality parameters.

The production of wine is quite complex and comprehend a wide number of variables, plant related, such as cultivar, grape ripeness, climate, and oenological related, such as the winemaking process, the equipment used. These variables can influence the outcome of the process, and therefore need to be deepened to get more possible information and be able to know the behaviour and influence of the different parameters on the application of pulsed electric fields.

Further studies can be addressed to the use of other cultivars, to study the behaviour of different grapes to the application of this technology, reduction of SO₂, and the application of the treatment in different steps of winemaking process. As evinced in literature, this technology can be applied, with positive results, to decrease the productive costs, time and increase quality.

List of references

- Abca E. E., & Akdemir E., G. (2014). *Processing of Red Wine by Pulsed Electric Fields with Respect to Quality Parameters. Journal of Food Processing and Preservation, vol. 39, pag. 758–767.* doi:10.1111/jfpp.12285
- Alkhafaji S. (2006) An Investigation on the non-thermal pasteurisation using pulsed electric fields. Thesis (PhD--Chemical and Materials Engineering)--University of Auckland. <http://hdl.handle.net/2292/543>
- Aronsson, K.A., Lindgren, M., Johansson, B.R., & Rönner, U. (2001). Inactivation of microorganisms using pulsed electric fields: the influence of process parameters on *Escherichia coli*, *Listeria innocua*, *Leuconostoc mesenteroides* and *Saccharomyces cerevisiae*. *Innovative Food Science and Emerging Technologies, vol. 2, pag. 41-54.*
- Arshad, R. N., Abdul-Malek, Z., Munir, A., Buntat, Z., Ahmad, M. H., Jusoh, Y. M., Bekhit, A. E.-D., Roobab, U., Manzoor, M. F., & Adil, R. M. (2020). Electrical systems for pulsed electric field applications in the food industry: An engineering perspective. *Trends in Food Science & Technology*. Pages 1-13, SSN 0924-2244, <https://doi.org/10.1016/j.tifs.2020.07.008>.
- Asavasanti, S., Stroeve, P., Barrett, D.M., Jernstedt, J.A., & Ristenpart, W.D. (2012). Enhanced electroporation in plant tissues via low frequency pulsed electric fields: Influence of cytoplasmic streaming. *Biotechnology Progress, vol. 28.*
- ASTM (2000), Standard Guide for Sensory Evaluation of Beverages Containing Alcohol, E1879-00, West Conshohocken, PA, ASTM.
- Barbosa-Cànovas, G. V., Gongora-Nieto, M. M., Pothakamury, U. R., and Swanson, B. G. (1999). "Preservation of foods with pulsed electric fields". *Academic Press*, San Diego, USA.
- Barsotti, L., P. Merle, and J. Cheftel. (1999). Food processing by pulsed electric fields. I. Physical aspects. *Food Reviews International*. Vol. 15, pag. 163-180.
- Bisson, L.F., & Kunkee, R.E. (1993). Microbial interactions during wine production. In J.G. Zeikus, & A.E. Johnson (Eds.), *Mixed cultures in biotechnology*. Pag. 37–68. New York: Mc-Graw-Hill.
- Boulton R.B., (2001). The copigmentation of anthocyanins and its role in the colour of red wine: a critical review. *American Journal of Enology and Viticulture* vol.55, pag. 67–87
- Boussetta, N., Vorobiev, E., Le, L. H., Cordin-Falcimaigne, A., & Lanoisellé, J.-L. (2012). Application of electrical treatments in alcoholic solvent for polyphenols extraction from grape seeds. *LWT - Food Science and Technology, vol. 46, pag. 127–134.*
- Bruhn, R. E., Pedrow, P. D., and Olsen, R. G. (1998). Heat conduction in microbes exposed to pulsed electric fields. *Transactions on Dielectrics and Electrical Insulation*, Montreal, Quebec, Canada, vol. 5, pag. 878-885.

Buckow, R., Ng, S.Y., & Toepfl, S. (2013). Pulsed Electric Field Processing of Orange Juice: A Review on Microbial, Enzymatic, Nutritional, and Sensory Quality and Stability. *Comprehensive reviews in food science and food safety*, vol. 12, pag. 455-467.

Busse-Valverde, N., Gómez-Plaza, E., López-Roca, J. M., Gil-Muñoz, R., Fernández-Fernández, J. I., & Bautista-Ortín, A. B. (2010). Effect of different enological practices on skin and seed proanthocyanidins in three varietal wines. *Journal of Agriculture and Food Chemistry*, vol. 58, pag.11333-11339.

Cerpa-Calderon, F. K., & Kennedy, J. A. (2008). Berry integrity and extraction of skin and seed proanthocyanidins during red wine fermentation. *Journal of Agricultural and Food Chemistry*, vol. 19, pag. 9006–9014.

Chotphruethipong, L., Aluko, R. E., & Benjakul, S. (2019). Effect of pulsed electric field-assisted process in combination with porcine lipase on defatting of seabass skin. *Journal of Food Science*, vol. 84, pag. 1799–1805.

Commission Regulation (EC) No 606 (2009). Laying down certain detailed rules for implementing Council Regulation (EC) No 479/2008 as regards the categories of grapevine products, oenological practices and the applicable restrictions. *Official Journal of the European Communities, L*, vol. 193, pag. 1–59

Comuzzo P, Marconi M, Zanella G, Querzè M. (2018). Pulsed electric field processing of white grapes (cv. Garganega): Effects on wine composition and volatile compounds. *Food Chem.* 2018 Oct 30; vol. 264;pag. 16-23. doi: 10.1016/j.foodchem.2018.04.116. Epub 2018 Apr 26.

Comuzzo, P., Voce, S., Grazioli, C., Tubaro, F., Marconi, M., Zanella, G., & Querzè, M. (2020). Pulsed Electric Field Processing of Red Grapes (cv. Rondinella): Modifications of Phenolic Fraction and Effects on Wine Evolution. *Foods*, vol. 9.

Delsart, C., Grimi, N., Boussetta, N., Miot Sertier, C., Ghidossi, R., Vorobiev, E., & Mietton Peuchot, M. (2015). *Impact of pulsed-electric field and high-voltage electrical discharges on red wine microbial stabilization and quality characteristics. Journal of Applied Microbiology*, vol. 120, pag. 152–164. doi:10.1111/jam.12981

Delso, C., Berzosa A., Sanz J., Alvarez I., Raso J. (2021). 'Microbial Decontamination by Pulsed Electric Fields (PEF) in Winemaking', in A. Morata, I. Loira, C. González (eds.), *Grapes and Wine*, London. 10.5772/intechopen.101112.

Dunn, J. E., and Pearlman, J. S. (1987). Methods and apparatus for extending the shelf life of fluid food products. US Patent 4695472.

El Darra N.,Rajha N.H., Ducasse M.A., Turk M.F., Grimi N., Maroun R.G., Louka N., Vorobiev E. (2016). Effect of pulsed electric field treatment during cold maceration and alcoholic fermentation on major red wine qualitative and quantitative parameters, *Food Chemistry*, vol. 213, pag. 352-360, <https://doi.org/10.1016/j.foodchem.2016.06.073>.

Electric Field strength | Physics Wiki | Fandom

- Elgenedy, M. A., Darwish, A., Ahmed, S., & Williams, B. W. (2017). A transition arm modular multilevel universal pulse-waveform generator for electroporation applications. *Transactions on Power Electronics*, vol. 32, pag. 8979–8991.
- Esplugas, S., Pagan, R., Barbosa-Canovas G., Swanson B. (2019). Engineering aspects of the continuous treatment of fluid foods by pulsed electric fields. *Pulsed Electric Fields in Food Processing: Fundamental Aspects and Applications*, pag. 31–44.
- Evans G, Cox DN (2006) Australian consumers' antecedents of attitudes towards foods produced by novel technologies. *Br Food J* vol. 108 pag. 916–93.
- Faridnia F., Burritt D.J., Bremer P.J., Oey I. (2015). Innovative approach to determine the effect of pulsed electric fields on the microstructure of whole potato tubers: use of cell viability, microscopic images and ionic leakage measurements. *Food Res Int* vol. 77, pag. 556–564
- Fauster, T., Philipp, C., Hanz, K., Scheibelberger, R., Teufl, T., Nauer, S., Jaeger, H. (2020). Impact of a combined pulsed electric field (PEF) and enzymatic mash treatment on yield, fermentation behaviour and composition of white wine. *European Food Research and Technology*, vol. 246, pag. 609-620. Available from <https://doi.org/10.1007/s00217-020-03427>.
- Fernandes D.A., (2015). Assessment of a Pulsed Electric Field based Treatment for Marine Microalgae Cell Disruption. Thesis, Biological Engineering at Instituto Superior Técnico, University of Lisbon. Lisbon, Portugal.
- Frewer L., Bergmann K., Brennan M., Lion R., Meertens R., Rowe G., Siegrist M., Vereijken C. (2011). Consumer response to novel agri-food technologies: implications for predicting consumer acceptance of emerging food technologies. *Trends Food Sci Technol*. Vol.22, pag. 442–456.
- Gad, A., Jayaram, S. H., & Pritzker, M. (2014). Performance of electrode materials during food processing by pulsed electric fields. *Transactions on Plasma Science*, vol. 42, pag. 3161–3166.
- García-Ruiz, A., González-Rompinelli, E.M., Bartolomé, B., & Moreno-Arribas, M.V. (2011). Potential of wine-associated lactic acid bacteria to degrade biogenic amines. *International Journal of Food Microbiology*, vol. 148, pag. 115–120. <http://dx.doi.org/10>.
- García-Ruiz, A., Tabasco, R., Requena, T., Claisse, O., Lonvaud-Funel, A., Bartolomé, B., et al. (2013). Genetic diversity of *Oenococcus oeni* isolated from wines treated with phenolic extracts as antimicrobial agents. *Food Microbiology*, vol. 36, pag. 267–274. <http://dx.doi.org/10.1016/j.fm.2013.06.012>.
- Garde-Cerdán, C. Ancín Azpilicueta, (2006). Review of quality factors on wine ageing in oak barrels, *Trends Food Sci. Technol*. Vol. 17, pag. 438-447. <https://doi.org/10.1016/J.TIFS.2006.01.008>
- Garde-Cerdán, M. Arias-Gil, A.R. Marsellés-Fontanet, C. Ancín Azpilicueta, O. Martín-Belloso (2007). Effects of thermal and non-thermal processing treatments on fatty acids and free amino acids of grape juice, *Food Control*. Vol. 18, pag. 473-479. <https://doi.org/10.1016/j.foodcont.2005.12.004>.

- Gaskova, D., Sigler, K., Janderova, B., Plasek, J. (1996). Effect of high voltage electric pulses on yeast cells: Factors influencing the killing efficiency. *Bioelectrochem. Bioenergetics*. Vol. 39, pag. 195-202.
- Gaudreau, M., Hawkey, T., Petry, J., & Kempkes, M. (2005). Solid-state power systems for pulsed electric field (PEF) processing. Pag. 1278–1281.
- Genovese J, Tappi S, Luo W, Tylewicz U, Marzocchi S, Marziali S, Romani S, Ragni L, Rocculi P (2019) Important factors to consider for acrylamide mitigation in potato crisps using pulsed electric fields. *Innov Food Sci Emerg Technol*. Vol. 55, pag. 18–26.
- Giteru S.G., Oey I., Ali M.A., (2018). Feasibility of using pulsed electric fields to modify biomacromolecules: A review, *Trends in Food Science & Technology*, Vol. 72, pag. 91-113.
- Gongora-Nieto M., Sepúlveda D., Pedrow P., Barbosa-Canovas G., Swanson, B. (2002). Food processing by pulsed electric fields: Treatment delivery, inactivation level, and regulatory aspects. *LWT-Food Science and Technology*. Vol. 35, pag. 375–388.
- González-Marco, A., & Ancin-Azpilicueta, C. (2006). Influence of lees contact on evolution of amines in Chardonnay wine. *Journal of Food Science*, vol. 71, pag. 544-548. Doi.org/10.1111/j.1750-3841.2006.00182.x.
- González-Arenzana, J. Portu, R. López, N. López, P. Santamaría, T. Garde-Cerdán, I. López-Alfaro. (2015). Inactivation of wine-associated microbiota by continuous pulsed electric field treatments, *Innov. Food Sci. Emerg. Technol*. Vol. 29, pag. 187-192. <https://doi.org/10.1016/j.ifset.2015.03.009>.
- González-Arenzana, I. LópezAlfaro, A.R. Gutiérrez, N. López, P. Santamaría, R. López. (2019). Continuous pulsed electric field treatments' impact on the microbiota of red Tempranillo wines aged in oak barrels, *Food Biosc*. Vol. 27, pag. 54-59. <https://doi.org/10.1016/J.FBIO.2018.10.012>
- Grahl, T., and Markl, H. (1996). Killing of microorganisms by pulsed electric fields. *Applied Microbiology and Biotechnology*. Vol. 45, pag. 148-157.
- Grimi, N., Lebovka, N. I., Vorobiev, E., & Vaxelaire, J. (2009). *Effect of a Pulsed Electric Field Treatment on Expression Behavior and Juice Quality of Chardonnay Grape*. *Food Biophysics*. Vol. 4, pag. 191–198. doi:10.1007/s11483-009-9117-8
- Guionet, A., David, F., Zaepffel, C., Coustets, M., Helmi, K., Cheype, C., et al. (2015). E. coli electroeradication on a closed loop circuit by using milli-, micro- and nanosecond pulsed electric fields: Comparison between energy costs. *Bioelectrochemistry*, vol.103, pag. 65–73.
- Guth, H. (1997). Quantitation and sensory studies of character impact odorants of different white wine varieties. *Journal of Agricultural and Food Chemistry*, vol. 45, pag. 3027–3032.
- Hamilton, W. A., and Sale, A. J. H. (1967). Effects of high electric fields on microorganisms II. Mechanism of action of the lethal effect. *Biochemica et Biophysica Acta*. Vol. 148, pag. 789-800.

- Ho, S., and Mittal, G. S. (2000). High voltage pulsed electrical field for liquid food pasteurization. *Food Reviews International*. Vol. 16, pag. 395-434.
- Huang, K., & Wang, J. (2009). Designs of pulsed electric fields treatment chambers for liquid foods pasteurization process: A review. *Journal of Food Engineering*, vol. 95, pag. 227–239.
- Huang, K., Yu, L., Liu, D., Gai, L., & Wang, J. (2013). Modeling of yeast inactivation of PEF-treated Chinese rice wine: Effects of electric field intensity, treatment time and initial temperature. *Food Research International*, vol. 54, pag. 456–467
- Ilona, G., Ewa, K., & Andrzej, C. (2018). Impact of pulsed electric field on the colour of wine made from grapes Marechal Foch variety. *2018 Applications of Electromagnetics in Modern Techniques and Medicine (PTZE)*, pag. 33-36.
- Jaeger H., Meneses N., Moritz J., Knorr D. (2010). Model for the differentiation of temperature and electric field effects during thermal assisted PEF processing. *J Food Eng* vol. 100, pag. 109–118.
- Jambrak, A., Djekić, I., & Van Impe, J. (2018). Non-thermal food processing: Modelling of processes towards safety, quality and sustainability. In 10th international conference on simulation and modelling in the food and bio-industry 2018 Vol. 2018, pag. 19–21. FOODSIM
- Jayaram, S., and Castle, G. S. P. (1992). Kinetics of sterilization of *Lactobacillus brevis* cells by the application of high voltage pulses. *Biotechnology and Bioengineering*. Vol. 40, pag. 1412-1420.
- Jeanet, R., Baron, F., Nau, F., Roignant, M., and Brule, G. (1999). High intensity pulsed electric fields applied to egg white: Effect of *Salmonella enteritidis* inactivation and protein denaturation. *Journal of Food Protection*. Vol. 62, pag. 1381-1386.
- Kandušer, M., Belic, A., Čorović, S., & Škrjanc, I. (2017). Modular Serial Flow Through device for pulsed electric field treatment of the liquid samples. *Scientific Reports*. Vol. 7, no.1, pag.. 1-12. <https://doi.org/10.1038/s41598-017-08620-8>
- Katiyo, W, Yang, R., & Zhao, W. (2017). Effects of combined pulsed electric fields and mild temperature pasteurization on microbial inactivation and physicochemical properties of cloudy red apple juice (*Malus pumila Niedzwetzkyana* (Dieck)). *Journal of Food Safety*, 37(4), Article e12369.
- Kempkes M.A. (2017) Industrial Pulsed Electric Field Systems. In: Miklavčič D. (eds) *Handbook of Electroporation*. Springer, Cham. https://doi.org/10.1007/978-3-319-32886-7_211
- Korolczuk, J., Mc Keag, J. R., Fernandez, J. C., Baron, F., Grosset, N., & Jeanet, R. (2006). Effect of pulsed electric field processing parameters on *Salmonella enteritidis* inactivation. *Journal of Food Engineering*. Vol. 75, pag. 11–20
- Kumar, Y., Patel, K. K., & Kumar, V. (2015). Pulsed electric field processing in food technology. *International Journal of Engineering Studies and Technical Approach*. Vol. 1, pag. 6–17.

- Li, X., & Farid, M. (2016). A review on recent development in non-conventional food sterilization technologies. *Journal of Food Engineering*. Vol. 182, pag. 33–45.
- Longin, C., Degueurce, C., Julliat, F., Guilloux-Benatier, M., Rousseaux, & Alexandre, H. (2016). Efficiency of population-dependent sulfite against *Brettanomyces bruxellensis* in red wine. *Food Research International*. Vol. 89, pag. 620–630.
- López, N., Puértolas, E., Condón, S., Álvarez, I., & Raso, J. (2008). Application of pulsed electric fields for improving the maceration process during vinification of red wine: influence of grape variety. *European Food Research and Technology*. Vol. 227, pag. 1099-1107. <https://doi.org/10.1007/s00217-008-0825-y>.
- Luengo, E., Franco, E., Ballesteros, F. *et al.* (2013). Winery Trial on Application of Pulsed Electric Fields for Improving Vinification of Garnacha Grapes. *Food Bioprocess Technol.* Vol. 7, pag. 1457–1464. <https://doi.org/10.1007/s11947-013-1209-2>.
- Malfeito-Ferreira, M. (2014). Wine spoilage yeasts and bacteria. In C.A. Batt, & M.L. Tortorello (Eds.), *Encyclopedia of food microbiology* pag. 805–810 (2nd ed.). Oxford: Academic Press. <http://dx.doi.org/10.1016/B978-0-12-384730-0.00390-6>.
- Mannozi, C., Rompoonpol, K., Fauster, T., Tylewicz, U., Romani, S., Dalla Rosa, M., et al. (2019). Influence of pulsed electric field and ohmic heating pretreatments on enzyme and antioxidant activity of fruit and vegetable juices. *Foods*. Vol. 8, pag. 247.
- Marsellés-Fontanet, A. Puig, P. Olmos, S. Mínguez-Sanz, O. MartínBelloso. (2009). Optimising the inactivation of grape juice spoilage organisms by pulse electric fields, *Int. J. Food Microbiol.* Vol. 130, pag. 159-165. <https://doi.org/10.1016/j.ijfoodmicro.2008.12.034>
- Marsellés-Fontanet, A. PuigPujol, P. Olmos, S. Mínguez-Sanz, O. Martín-Belloso, (2013). A Comparison of the Effects of Pulsed Electric Field and Thermal Treatments on Grape Juice, *Food Bioprocess Technol.* Vol. 6, pag. 978-987. <https://doi.org/10.1007/s11947-011-0731-3>.
- Martin, O., Qin, B. L., Chang, F. J., Barbosa-Ca`novas, G. V., and Swanson, B. G. (1997). Inactivation of *Escherichia coli* in skim milk by high intensity pulsed electric fields. *Journal of Food Process Engineering*. Vol. 20, pag. 317-336.
- Martinez, J. M., Cebria´n, G., A´lvarez, I., & Raso, J. (2016). Release of mannoproteins during *Saccharomyces cerevisiae* autolysis induced by pulsed electric field. *Frontiers in Microbiology*. Vol. 7. <https://doi.org/10.3389/fmicb.2016.01435>
- Martinez, J. M., Delso, C., Maza, M. A., A´lvarez, I., & Raso, J. (2019). Pulsed electric fields accelerate release of mannoproteins from *Saccharomyces cerevisiae* during aging on the lees of Chardonnay wine. *Food Research International*. Vol. 116, pag. 795-801. <https://doi.org/10.1016/j.foodres.2018.09.013>

- Masood, H., Diao Y., Cullen, P. J., Lee, N. A., & Trujillo, F. J. (2018). A comparative study on the performance of three treatment chamber designs for radio frequency electric field processing. *Computers & Chemical Engineering*. Vol. 108, pag. 206–216.
- Maza, M. A., Delso, C., Alvarez, I., Raso, J., & Martinez, J. M. (2020). Effect of pulsed electric fields on mannoproteins release from *Saccharomyces cerevisiae* during the aging on lees of Caladoc red wine. *LWT*. Vol. 118. <https://doi.org/10.1016/j.lwt.2019.108788>.
- Maza M.A., Álvarez I., Raso J. (2022) Applications of Pulsed Electric Fields in Winemaking. In: Raso J., Heinz V., Alvarez I., Toepfl S. (eds) Pulsed Electric Fields Technology for the Food Industry. Food Engineering Series. Springer, Cham. https://doi.org/10.1007/978-3-030-70586-2_10
- McHugh, T., & Toepfl, S. (2016). Pulsed electric field processing for fruits and vegetables. *Food Technology*. Vol. 70, pag. 73–75
- Milani E.A., Silva F.V.M., (2022). Pasteurization of Beer by Non-Thermal Technologies. *Frontiers in Food Science and Technology* vol. 1, article 798676.
- Moonesan, M. S., & Jayaram, S. H. (2013). Effect of pulse width on medium temperature rise and microbial inactivation under pulsed electric field food treatment. *IEEE Transactions on Industry Applications*. Vol. 49, pag. 1767–1772.
- Morales De La Pena M., Salvia-Trujillo L., Rojas-Graü, M. A., Martín-Belloso O. (2017). Effects of high intensity pulsed electric fields or thermal pasteurization and refrigerated storage on antioxidant compounds of fruit juice-milk beverages. Part I: Phenolic acids and flavonoids. *Journal of Food Processing and Preservation*. Vol. 41, Article e12912.
- Morata, A., Bañuelos, M.A., López, C., Chenli, S., Vejarano, R., Loira, I., Palomero, F., Suárez- Lepe, J.A. (2020). Grape must processed by pulsed electric fields: Effect on the inoculation and development of non-*Saccharomyces* yeasts. *Food and Bioprocess Technology*. Vol. 13, pag. 1087-1094. <https://doi.org/10.1007/s11947-020-02458-1>.
- Naliyadhara, N., Kumar, A., Girisa, S., Daimary, U.D., Hegde, M., Kunnumakkara, A.B., (2022), Pulsed electric field (PEF): Avant-garde extraction escalation technology in food industry, *Trends in Food Science & Technology*. doi: <https://doi.org/10.1016/j.tifs.2022.02.019>.
- Niu D., Zeng X.A., Ren E.F., Xu F.Y., Li J., Wang M.S., Wang R. (2020). Review of the application of pulsed electric fields (PEF) technology for food processing in China, *Food Research International*, 137, article n° 109715.
- Ohshima, T., Sato, K., Terauchi, H., and Sato, M. (1997). Physical and chemical modifications of high voltage pulse sterilization. *Journal of Electrostatics*. Vol. 42, pag. 159-166.
- Ortega-Rivas, E., & Salmerón-Ochoa, I. (2014). Nonthermal food processing alternatives and their effects on taste and flavour compounds of beverages. *Critical Reviews in Food Science and Nutrition*. Vol. 54, pag. 190–207

- Ozturk, B., & Anli, E. (2017). Pulsed electric fields (PEF) applications on wine production: A review. Vol. 9 pag. 02-08. DOI <https://doi.org/10.1051/bioconf/20170902008>.
- Palaniappan, S., Sastry, S. K., & Richter, E. R. (1990). Effects of Electricity on Microorganisms - a Review. *Journal of Food Processing and Preservation*. Vol. 14, pag. 393-414.
- Pataro, G., & Ferrari, G. (2017). Modelling of electrochemical reactions during pulsed electric field treatment (handbook of electroporation (ed.)). Cham: Springer.
- Plumb, G. W., De Pascual-Teresa, S., Santos-Buelga, C., Cheynier, V., & Williamson, G. (1998). Antioxidant properties of catechins and proanthocyanidins: Effect of polymerisation galloylation and glycosylation. *Free Radical Research*. Vol. 29, pag. 351–353
- Pothakamury, U. R., Vega Mercado, H., Zhang, Q. H., Barbosa-Cañovas, G. V., and Swanson, B. G. (1996). Effect of growth stage and processing temperature on the inactivation of e-coli by pulsed electric fields. *Journal of Food Protection*. Vol. 59, pag. 1167-1171.
- Praporscic, I., Lebovka, N., Vorobiev, E., & Mietton-Peuchot, M. (2007). Pulsed electric field enhanced expression and juice quality of white grapes. *Separation and Purification Technology*. Vol. 52, pag. 520–526.
- Puértolas, N. López, S. Condón, J. Raso, I. Álvarez. (2009). Pulsed electric fields inactivation of wine spoilage yeast and bacteria, *Int. J. Food Microbiol.* Vol. 130, pag. 49-55. <https://doi.org/10.1016/j.ijfoodmicro.2008.12.035>
- Puligundla, Y.-R. Pyun, C. Mok. (2018). Pulsed electric field (PEF) technology for microbial inactivation in low-alcohol red wine, *Food Sci. Biotechnol.* Vol. 27, pag. 1691-1696. <https://doi.org/10.1007/s10068-018-0422-1>
- Jackson, R.S. Chem. Pulsed electric field. *J. Electrostat.* 70, 212–216 *Cons. of Grape and Wine. Wine Science-Third Edition*. Pag. 270–331 (San Diego: Academic Press, 2008)
- Qin BL., Pothakamury UR., Vega-Mercado H., Martin-Belloso O.M., Barbosa-Cañovas G.V., Swanson B.G. (1995). Food pasteurization using high-intensity pulsed electric fields. *Food Technol.* Vol. 12, pag. 55–60.
- Redondo L. M. and Fernando Silva J., "Repetitive High-Voltage Solid-State Marx Modulator Design for Various Load Conditions," in *IEEE Transactions on Plasma Science*, vol. 37, no. 8, pp. 1632-1637, Aug. 2009, doi: 10.1109/TPS.2009.2023221.
- Renouf, V., Claisse, O., & Lonvaud-Funel, A. (2007). Inventory and monitoring of wine microbial consortia. *Applied Microbiology and Biotechnology*. Vol. 75, pag. 149–164. <http://dx.doi.org/10.1007/s00253-006-0798-3>.
- Ribèreau-Gayon, Dubourdiou D., Donèche B., Lonvaud A. (2017). *Traité d'œnologie*. 1. Microbiologie du vin 4^a edition
- Ribèreau-Gayon, P., Glories, Y., Maujean, A., & Dubourdiou, D. (2006). *Handbook of oenology. The Chemistry of Wine Stabilization and Treatments*. New York: John Wiley & Sons.

- Roodenburg B., Morren J., Berg H.E., de Haan S.W.H. (2005). Metal release in a stainless steel pulsed electric field (PEF) system. Part II. The treatment of orange juice; related to legislation and treatment chamber lifetime. *Innov. Food Sci. Emerg. Technol.* Vol. 6, pag. 337–345.
- Sack, M., & Mueller, G. (2017). Design considerations for electroporation reactors. *Transactions on Dielectrics and Electrical Insulation.* Vol. 24, pag. 1992–2000.
- Sale, A., & Hamilton, W. (1967). Effects of high electric fields on microorganisms: I. Killing of bacteria and yeasts. *Biochimica et Biophysica Acta (BBA)- General Subjects.* Vol. 148, pag. 781-788
- Saliba, L.A. Ovington, C. Moran. (2013). Consumer demand for low-alcohol wine in an Australian sample, *Int. J. Wine Res.* 5 1. Vol. 2013 Pag. 1-8. <https://doi.org/10.2147/IJWR.S41448>.
- Sarni-Manchado, P., Cheynier, V., & Moutounet, M. (1999). Interactions of grape seed tannins with salivary proteins. *Journal of Agricultural and Food chemistry.* Vol. 47, pag. 42–47.
- Schilling, S., Alber, T., Toepfl, S., Neidhart, S., Knorr, D., Schieber, A., & Carle, R. (2007). Effects of pulsed electric field treatment of apple mash on juice yield and quality attributes of apple juices. *Innovative Food Science and Emerging Technologies.* Vol. 8, pag. 127–134.
- Silva, F.V.M., van Wyk, S. (2021). Emerging, Non-Thermal Technologies as Alternative to SO₂ for the Production of Wine. *Foods.* Vol. 10, pag. 2175.
- Singh, B.P., *Biofuel crops: production, physiology and genetics.* 2013: CABI.
- Soliva-Fortuny R., Vendrell-Pacheco M., Martin-Belloso O., Elez– Martinez P. (2017) Effect of pulsed electric fields on the antioxidant potential of apples stored at different temperatures. *Postharvest Biol. Technol.* Vol. 132, pag. 195–201.
- Stadler, E., Fischer, U., (2020). Sanitization of Oak Barrels for Wine A Review, *J. Agric. Food Chem.* Vol. 68, pag. 5283-5295. <https://doi.org/10.1021/acs.jafc.0c00816>.
- Stanley, D. W. (1991). Biological membrane deterioration and associated quality losses in food tissues. In “Critical reviews in food science and nutrition”. Clydesdale F. M., ed., CRC Press, New York.
- Sun, Y., Zhang, M., & Fang, Z. (2019). Efficient physical extraction of active constituents from edible fungi and their potential bioactivities: A review. *Trends in Food Science & Technology.* Vol. 105, pag. 468-482.
- Tao, Y., & Zhang, L. (2010). Intensity prediction of typical aroma characters of cabernet sauvignon wine in Changli County (China). *LWT – Food Science and Technology.* Vol. 43, pag. 1550–1556.
- Teissie, J., Golzio, M., & Rols, M. P. (2005). Mechanisms of cell membrane electropermeabilization: A minireview of our present (lack of ?) knowledge. *Biochimica et Biophysica Acta.* Vol. 1724, pag. 270–280.
- Toepfl, S., V. Heinz, and D. Knorr. (2006). Applications of pulsed electric fields technology for the food industry, in *Pulsed electric fields technology for the food industry.* Springer. Pag. 197-221

- Toepfl, S., Heinz, V., & Knorr, D. (2007). High intensity pulsed electric fields applied for food preservation. *Chemical Engineering and Processing: Process intensification*. Vol. 46, pag. 537–546.
- Tokusoglu, O., Swanson, B. G. (2014). Improving food quality with novel food processing technologies. *Court: CRC Press*
- Tsong T.Y. (1996) Electrically stimulated membrane breakdown. In: Lynch PT, Davey MR (eds) *Electrical manipulation of cells*. Chapman & Hall, New York, pag. 15–36.
- Tylewicz, U. (2020). How does pulsed electric field work? *Pulsed Electric Fields to Obtain Healthier and Sustainable Food for Tomorrow*. Pag. 3-21. Elsevier. <https://doi.org/10.1016/B978-0-12-816402-0.00001-X>.
- Van Wyk, S., Farid, M. M., & Silva, F. V. (2018). SO₂, high pressure processing and pulsed electric field treatments of red wine: Effect on sensory, *Brettanomyces* inactivation and other quality parameters during one year storage. *Innovative Food Science & Emerging Technologies*. Vol. 48, pag. 204–211. <https://doi.org/10.1016/j.ifset.2018.06.016>.
- Van Wyk, S., & Silva, F. V. M. (2019). Nonthermal preservation of wine. Chapter 7 in: *Preservatives and Preservation Methods for the Beverage Industry*, edited by Alexandru M. Grumezescu, Alina Maria Holban. The Science of Beverages series. Elsevier. Vol. 15, pag. 203-235.
- Van Wyk, S., Silva, F.V.M., Farid, M.M. (2019). Pulsed electric field treatment of red wine: Inactivation of *Brettanomyces* and potential hazard caused by metal ion dissolution. *Innovative Food Science and Emerging Technologies*. Vol. 52, pag. 57–65.
- Van Wyk, Sanelle, Lewis Hong, and Filipa V.M. Silva. (2021). Non-Thermal High Pressure Processing, Pulsed Electric Fields and Ultrasound Preservation of Five Different Table Wines" *Beverages* vol. 7, pag. 4-69. <https://doi.org/10.3390/beverages7040069>.
- Vega-Mercado, H., Gongora-Nieto, M. M., Barbosa-Cánovas, G. V., and Swanson, B. G. (1999). Nonthermal Preservation of Liquid Foods Using Pulsed Electric Fields. In "Handbook of Food Preservation". Rahman M. S.
- Vidal S., L. Francis, A. Noble, M. Kwiatkowski, V. Cheynier & E. Waters. (2004). Taste and mouthfeel properties of different types of tannin-like polyphenolic compounds and anthocyanins in wine. *Analytica Chimica Acta*. Vol. 513, pag. 57–65.
- Vorobiev, E., & Lebovka, N. I. (2012). New and promising applications of pulsed electric field treatments in bio & food processing. *Proceeding of the International Conference Bio & Food Electrotechnologies – BFE 2012, Book of Full Papers*. Pag. 88–92.
- Wang, L.H., Pyatkovskyy T., Yousef, A., Zeng, X.-A., & Sastry, S. K. (2020). Mechanism of *Bacillus subtilis* spore inactivation induced by moderate electric fields. *Innovative Food Science & Emerging Technologies*. Vol. 62, art. 102349.
- Wouters, P. C., and Smelt, J. P. P. M. (1997). Inactivation of microorganisms with pulsed electric fields: potential for food preservation. *Food Biotechnology*. Vol. 11, pag. 193-229.

- Yang N., K. Huang, C. Lyu, J. Wang. (2016) Pulsed electric field technology in the manufacturing processes of wine, beer, and rice wine: A review. *Food Control*. Vol. 61, pag. 28–38.
- Yin, Y., Zhang, Q. H., and Sastry, S. K. (1997). High voltage pulsed electric field treatment chambers for the preservation of liquid food products.
- Zbinden A. (2011). Investigation of pulsed electric field (PEF) as an intensification pre-treatment for solvent lipid extraction from microalgae, utilizing ethyl acetate as a greener substitute to chloroform-based extraction. University of Kansas.
- Zhang Q., Barbosa-Canovas G.V., Swanson B.G. (1995). Engineering aspects of pulsed electric field pasteurization. *J. Food. Eng.* Art. 25, pag. 261–281.
- Zhang, R., Li, X., Wang, Z., Chen, Z., & Du, G. (2018). Prediction of the electric discharge occurrence under repetitive bipolar rectangular pulsed electric field < 20 kV/cm. *Applied Physics Letters*. Vol. 113, art. n°.063701.
- Zimmermann, U., Pilwat, G., & Riemann, F. (1974). Dielectric breakdown of cell membranes. *Biophysical journal*. Vol. 14, pag. 881-899.

Appendix

WINE COLOUR ASSESSMENT

This is a consumer test so there is no right or wrong answer. We are grateful for your participation. Your honest opinion is appreciated.

1. Examine the colour of the three wines from left to right. Two of these samples are identical in colour and one is different. **Select with a circle the odd sample.** In case no difference is detected, please select randomly one wine.

<input type="checkbox"/>	<input type="checkbox"/>	<input type="checkbox"/>
--------------------------	--------------------------	--------------------------

2. Indicate the degree of difference between the odd sample selected and the two identical samples:

None	<input type="checkbox"/>
Slight	<input type="checkbox"/>
Moderate	<input type="checkbox"/>
Great	<input type="checkbox"/>

3. Indicate by placing a mark if the following samples are acceptable in terms of colour:

Identical samples	<input type="checkbox"/>
Odd sample	<input type="checkbox"/>
No preference	<input type="checkbox"/>

4. Free comments:

WINE TASTE ASSESSMENT

This is a consumer test so there is no right or wrong answer. We are grateful for your participation. Your honest opinion is appreciated.

1. Smell and taste the three wine samples from left to right. Two of the wines are identical and one is different. **Select with a circle the odd sample.** If no difference detected, you must do a random selection of one wine.

<input type="checkbox"/>	<input type="checkbox"/>	<input type="checkbox"/>
--------------------------	--------------------------	--------------------------

2. Indicate the degree of difference between the odd sample and the identical samples:

None	<input type="checkbox"/>
Slight	<input type="checkbox"/>
Moderate	<input type="checkbox"/>
Great	<input type="checkbox"/>

3. Which wine sample do you like most?

The two identical samples	<input type="checkbox"/>
The different sample	<input type="checkbox"/>
No preference	<input type="checkbox"/>

4. Indicate by placing a mark if the following samples are acceptable in terms of flavour:

Identical samples	<input type="checkbox"/>
Odd sample	<input type="checkbox"/>

5. Free comments:

Chi-Square Right-Tail Probability ($\geq \chi^2$)										
DF	0.995	0.99	0.975	0.95	0.9	0.1	0.05	0.025	0.01	0.005
1	---	---	0.001	0.004	0.016	2.706	3.841	5.024	6.635	7.879
2	0.010	0.020	0.051	0.103	0.211	4.605	5.991	7.378	9.210	10.597
3	0.072	0.115	0.216	0.352	0.584	6.251	7.815	9.348	11.345	12.838
4	0.207	0.297	0.484	0.711	1.064	7.779	9.488	11.143	13.277	14.860
5	0.412	0.554	0.831	1.145	1.610	9.236	11.070	12.833	15.086	16.750
6	0.676	0.872	1.237	1.635	2.204	10.645	12.592	14.449	16.812	18.548
7	0.989	1.239	1.690	2.167	2.833	12.017	14.067	16.013	18.475	20.278
8	1.344	1.646	2.180	2.733	3.490	13.362	15.507	17.535	20.090	21.955
9	1.735	2.088	2.700	3.325	4.168	14.684	16.919	19.023	21.666	23.589
10	2.156	2.558	3.247	3.940	4.865	15.987	18.307	20.483	23.209	25.188
11	2.603	3.053	3.816	4.575	5.578	17.275	19.675	21.920	24.725	26.757
12	3.074	3.571	4.404	5.226	6.304	18.549	21.026	23.337	26.217	28.300
13	3.565	4.107	5.009	5.892	7.042	19.812	22.362	24.736	27.688	29.819
14	4.075	4.660	5.629	6.571	7.790	21.064	23.685	26.119	29.141	31.319
15	4.601	5.229	6.262	7.261	8.547	22.307	24.996	27.488	30.578	32.801
16	5.142	5.812	6.908	7.962	9.312	23.542	26.296	28.845	32.000	34.267
17	5.697	6.408	7.564	8.672	10.085	24.769	27.587	30.191	33.409	35.718
18	6.265	7.015	8.231	9.390	10.865	25.989	28.869	31.526	34.805	37.156
19	6.844	7.633	8.907	10.117	11.651	27.204	30.144	32.852	36.191	38.582
20	7.434	8.260	9.591	10.851	12.443	28.412	31.410	34.170	37.566	39.997
21	8.034	8.897	10.283	11.591	13.240	29.615	32.671	35.479	38.932	41.401
22	8.643	9.542	10.982	12.338	14.041	30.813	33.924	36.781	40.289	42.796
23	9.260	10.196	11.689	13.091	14.848	32.007	35.172	38.076	41.638	44.181
24	9.886	10.856	12.401	13.848	15.659	33.196	36.415	39.364	42.980	45.559
25	10.520	11.524	13.120	14.611	16.473	34.382	37.652	40.646	44.314	46.928
26	11.160	12.198	13.844	15.379	17.292	35.563	38.885	41.923	45.642	48.290
27	11.808	12.879	14.573	16.151	18.114	36.741	40.113	43.195	46.963	49.645
28	12.461	13.565	15.308	16.928	18.939	37.916	41.337	44.461	48.278	50.993
29	13.121	14.256	16.047	17.708	19.768	39.087	42.557	45.722	49.588	52.336
30	13.787	14.953	16.791	18.493	20.599	40.256	43.773	46.979	50.892	53.672
40	20.707	22.164	24.433	26.509	29.051	51.805	55.758	59.342	63.691	66.766
50	27.991	29.707	32.357	34.764	37.689	63.167	67.505	71.420	76.154	79.490
60	35.534	37.485	40.482	43.188	46.459	74.397	79.082	83.298	88.379	91.952
70	43.275	45.442	48.758	51.739	55.329	85.527	90.531	95.023	100.425	104.215
80	51.172	53.540	57.153	60.391	64.278	96.578	101.879	106.629	112.329	116.321
90	59.196	61.754	65.647	69.126	73.291	107.565	113.145	118.136	124.116	128.299
100	67.328	70.065	74.222	77.929	82.358	118.498	124.342	129.561	135.807	140.169

Sensorial analysis results

COLOUR									TASTE									
N°	None	Slight	Moderate	Great	Identical	Odd	None	N°	None	Slight	Moderate	Great	Identical	Different	No pref	Identical	Odd	
251	x				x			251				x	x			x		
375		x			x	x		375	x						x	x	x	
251			x		x			375			x				x	x		
574			x			x		574		x				x			x	
375		x			x	x		375		x			x			x	x	
375	x				x			375	x						x	x		
375		x			x			375		x				x			x	
375		x			x	x		375		x				x		x	x	
375		x			x	x		375		x				x		x	x	
375		x			x	x		375		x				x		x	x	
574	x				x			574				x		x	x	x	x	
375		x			x			375			x		x			x		
729	x				x	x		729			x		x			x		
729	x				x	x		729		x					x		x	
729	x				x			375		x				x			x	
574	x				x			574			x			x			x	
375	x				x			251			x		x			x	x	
375		x			x	x		375		x				x		x	x	
729	x				x	x		729		x				x		x	x	
574	x				x			574		x					x	x	x	
251	x				x	x		251							x	x	x	
729	x				x	x		729		x					x	x	x	
574		x			x	x		574		x			x			x	x	
375	x				x	x		375			x				x	x	x	
24	13	9	2	0	22	15	0	24	5	12	5	2	6	9	9	18	17	TOT.
9	2	5	1	0	6	6		10	2	6	1	0	1	6	3	6	8	CORRECT

CONTROL VS CONTROL+PEF2																		
COLOUR									TASTE									
N°	None	Slight	Moderate	Great	Identical	Odd	None	N°	None	Slight	Moderate	Great	Identical	Different	No pref	Identical	Odd	
375			x		x	x		375			x				x	x		
375	x				x			251			x			x			x	
671	x				x			476				x			x		x	
375		x			x	x		375		x			x			x	x	
671	x				x			476		x					x		x	
671	x				x	x		476			x						x	
476		x			x			476			x		x				x	
476	x				x	x		476			x						x	
671		x			x	x		251			x						x	
251		x			x			671		x							x	
671		x			x	x		375			x						x	
375		x			x			671		x							x	
476		x				x		671		x							x	
476			x			x		476		x							x	
375		x			x	x		251				x					x	
375			x		x			671				x					x	
375		x			x	x		375			x						x	
476				x	x	x		671		x							x	
476				x	x	x		375		x							x	
476				x	x	x		671				x					x	
375		x			x	x		375				x					x	
251		x			x			251			x						x	
671		x			x			671		x							x	
375		x			x			375			x						x	
24	5	14	3	2	20	13	/	24	1	8	9	6	3	17	4	11	19	TOT.
10	1	5	2	2	8	6	/	10	0	2	2	5	1	7	2	5	8	CORRECT

PEF1 VS PEF1+PEF2																		
COLOUR									TASTE									
N°	None	Slight	Moderate	Great	Identical	Odd	None	N°	None	Slight	Moderate	Great	Identical	Different	No pref	Identical	Odd	
791			x		x	x		791			x						x	
193			x			x		193			x						x	
193	x				x	x		193		x						x	x	
574	x				x	x		574		x						x	x	
791		x			x	x		791			x		x			x	x	
193	x				x	x		193			x					x	x	
791		x			x	x		791		x						x	x	
193	x				x	x		574		x						x	x	
791		x			x	x		574		x						x	x	
193	x				x	x		791		x						x	x	
193		x			x			193		x							x	
791				x	x			193			x						x	
729			x		x			729			x						x	
193				x		x		193				x					x	
574		x			x			791		x							x	
193				x	x			193			x						x	
193	x				x			193		x							x	
791		x			x	x		193				x					x	
193	x				x			791				x					x	
193		x			x			791		x							x	
193	x				x	x		574		x							x	
791			x		x	x		791			x						x	
574	x				x	x		193			x						x	
24	9	8	4	3	21	15	/	24	1	11	9	3	4	16	4	12	16	TOT.
10	0	3	3	3	8	6	/	9	0	3	5	1	0	7	2	1	7	CORRECT

Physico-chemical analysis results

- Alcohol strenght

Ethanol			
CE	PEF1	CE+PEF2	PEF1+PEF2
12.1	12.2	11.7	11.7
12.2	12.1	11.7	11.7
12.1	12.1	11.8	11.7

ANOVA: Single Factor

DESCRIPTION		Alpha 0.05						
<i>Group</i>	<i>Count</i>	<i>Sum</i>	<i>Mean</i>	<i>Variance</i>	<i>SS</i>	<i>Std Err</i>	<i>Lower</i>	<i>Upper</i>
CE	3	36.4	12.1333333	0.003333	0.006667	0.028867513	12.06676	12.1999
PEF1	3	36.4	12.1333333	0.003333	0.006667	0.028867513	12.06676	12.1999
CE+PEF2	3	35.2	11.7333333	0.003333	0.006667	0.028867513	11.66676	11.7999
PEF1+PEF2	3	35.1	11.7	4.73E-30	9.47E-30	0.028867513	11.63343	11.76657

ANOVA

<i>Sources</i>	<i>SS</i>	<i>df</i>	<i>MS</i>	<i>F</i>	<i>P value</i>	<i>Eta-sq</i>	<i>RMSSE</i>	<i>Omega Sq</i>
Between Groups	0.5225	3	0.17416667	69.66667	4.48E-06	0.963133641	4.818944	0.944954
Within Groups	0.02	8	0.0025					
Total	0.5425	11	0.04931818					

SD

CE	0,057735
PEF1	0,057735
CE+PEF1	0,057735
PEF1+PEF2	2,18E-15

- pH

pH			
CE	PEF1	CE+PEF2	PEF1+PEF2
3.43	3.48	3.44	3.47
3.44	3.49	3.44	3.48
3.44	3.46	3.44	3.48

ANOVA: Single Factor

DESCRIPTION					Alpha	0.05			
Group	Count	Sum	Mean	Variance	SS	Std Err	Lower	Upper	
CE	3	10.3	3.436666667	3.33333E-05	6.66667E-05	0.005	3.4251	3.448196687	
PEF1	3	10.4	3.476666667	0.000233333	0.000466667	0.005	3.4651	3.488196687	
CE+PEF2	3	10.3	3.44	0	0	0.005	3.4285	3.451530021	
PEF1+PEF2	3	10.4	3.476666667	3.33333E-05	6.66667E-05	0.005	3.4651	3.488196687	

ANOVA

Sources	SS	df	MS	F	P value	Eta-sq	RMSSE	Omega Sq
Between Groups	0.00443	3	0.001475	19.66666667	0.000475702	0.880597015	2.5604	0.823529412
Within Groups	0.0006	8	7.5E-05					
Total	0.00503	11	0.000456818					

SD

CE	0,005774
PEF1	0,015275
CE+PEF1	0
PEF1+PEF2	0,005774

- Total acidity

Total acidity			
CE	PEF1	CE+PEF2	PEF1+PEF2
5,33	5,28	5,55	5,51
5,4	5,3	5,55	5,55
5,5	5,32	5,48	5,55

ANOVA: Single Factor

DESCRIPTION	Alpha 0,05								
<i>Group</i>	<i>Count</i>	<i>Sum</i>	<i>Mean</i>	<i>Variance</i>	<i>SS</i>	<i>Std Err</i>	<i>Lower</i>	<i>Upper</i>	
CE	3	16,23	5,41	0,0073	0,0146	0,028674418	5,3439	5,476123325	
PEF1	3	15,9	5,3	0,0004	0,0008	0,028674418	5,2339	5,366123325	
CE+PEF2	3	16,58	5,5266667	0,001633333	0,00326667	0,028674418	5,4605	5,592789992	
PEF1+PEF2	3	16,61	5,5366667	0,000533333	0,00106667	0,028674418	5,4705	5,602789992	

ANOVA

<i>Sources</i>	<i>SS</i>	<i>df</i>	<i>MS</i>	<i>F</i>	<i>P value</i>	<i>Eta-sq</i>	<i>RMSSE</i>	<i>Omega Sq</i>
Between								
Groups	0,111933	3	0,0373111	15,12612613	0,00116473	0,850126582	2,2454	0,779324056
Within Groups	0,019733	8	0,0024667					
Total	0,131667	11	0,0119697					

CE	0,085440037
PEF1	0,02
CE+PEF1	0,040414519
PEF1+PEF2	0,023094011

- Total phenols

Total phenols mg/L (280nm)			
CE	PEF1	CE+PEF2	PEF1+PEF2
256.2025	256.6076	215.443	216.2531646
251.2658	257.2152	215.519	216.6582278
255.9747	257.2405	216.6329	220.4810127

ANOVA: Single Factor

DESCRIPTION					Alpha	0.05			
Group	Count	Sum	Mean	Variance	SS	Std Err	Lower	Upper	
CE	3	763.443038	254.48101	7.76606313	15.53213	1.071614	252.0099	256.9522	
PEF1	3	771.063291	257.0211	0.12839823	0.256796	1.071614	254.55	259.4922	
CE+PEF2	3	647.594937	215.86498	0.44373231	0.887465	1.071614	213.3938	218.3361	
PEF1+PEF2	3	653.392405	217.79747	5.44207659	10.88415	1.071614	215.3263	220.2686	

ANOVA

Sources	SS	df	MS	F	P value	Eta-sq	RMSSE	Omega Sq
Between Groups	4559.54	3	1519.8465	441.165959	3.2E-09	0.993992	12.12664	0.990994
Within Groups	27.56054	8	3.4450676					
Total	4587.1	11	417.0091					

SD

CE	2,786766
PEF1	0,358327
CE+PEF2	0,666132
PEF1+PEF2	2,332826

- Flavonoids

Flavonoids mg/L (280nm)			
CE	PEF1	CE+PEF2	PEF1+PEF2
159.1392	156	131.1646	132.1012658
159.2658	156.0253	131.2152	131.9493671
159.1899	156.1013	131.3165	132.0759494
151.0886	155.5949	129.2405	130.6582278
150.9873	155.6203	129.2152	130.6582278
151.2152	155.7215	129.2405	130.5063291
155.7468	155.9494	131.5949	134.7341772
155.6962	155.9241	131.5696	134.7341772
155.8734	155.9747	131.5443	134.6329114

ANOVA: Single Factor

DESCRIPTION					Alpha	0.05		
<i>Group</i>	<i>Count</i>	<i>Sum</i>	<i>Mean</i>	<i>Variance</i>	<i>SS</i>	<i>Std Err</i>	<i>Lower</i>	<i>Upper</i>
CE	9	1398.2025	155.3558	12.409567	99.2765	0.684788	153.961	156.750
PEF1	9	1402.9113	155.8790	0.0342537	0.27403	0.684788	154.484	157.279
CE+PEF2	9	1176.1012	130.6779	1.1989709	9.59176	0.684788	129.283	132.072
PEF1+PEF2	9	1192.0506	132.4500	3.2388684	25.9109	0.684788	131.055	133.844

ANOVA

<i>Sources</i>	<i>SS</i>	<i>df</i>	<i>MS</i>	<i>F</i>	<i>P value</i>	<i>Eta-sq</i>	<i>RMSSE</i>	<i>Omega Sq</i>
Btwn Groups	5222.4	3	1740.826	412.47747	1.21E-25	0.974792	6.76984	0.97166
Within Groups	135.05	32	4.220415					
Total	5357.2	35	153.0723					

SD

CE	3,522722
PEF1	0,185078
CE+PEF2	1,094975
PEF1+PEF2	1,799686

- Non-flavonoids

Non flavonoids mg/L (280nm)			
CE	PEF1	CE+PEF2	PEF1+PEF2
97.06329	100.6076	84.27848	84.15189873
96.93671	100.5823	84.22785	84.30379747
97.01266	100.5063	84.12658	84.17721519
100.1772	101.6203	86.27848	86
100.2785	101.5949	86.3038	86
100.0506	101.4937	86.27848	86.15189873
100.2278	101.2911	85.03797	85.74683544
100.2785	101.3165	85.06329	85.74683544
100.1013	101.2658	85.08861	85.84810127

ANOVA: Single Factor

DESCRIPTION					Alpha	0.05			
Group	Count	Sum	Mean	Variance	SS	Std Err	Lower	Upper	
CE	9	892.12658	99.12517	2.5369509	20.2956	0.345746	98.4209	99.8294	
PEF1	9	910.27848	101.1420	0.2035644	1.62851	0.345746	100.437	101.846	
CE+PEF2	9	766.68354	85.18706	0.8183695	6.54695	0.345746	84.4828	85.8913	
PEF1+PEF2	9	768.12658	85.34739	0.7445566	5.95645	0.345746	84.6431	86.0516	

ANOVA

Sources	SS	df	MS	F	P value	Eta-sq	RMSSE	Omega Sq
Btwn Groups	2007.5	3	669.1685	621.98453	1.95E-28	0.98314	8.31320	0.98104
Within Groups	34.427	32	1.075860					
Total	2041.9	35	58.34094					

SD

CE	1,592781
PEF1	0,451181
CE+PEF2	0,904638
PEF1+PEF2	0,862877

- Turbidity

Turbidity			
CE	PEF1	CE+PEF2	PEF1+PEF2
4.84	7.98	70.6	59.9
4.57	8.62	70.5	59.6
4.69	10.3	70.2	59.8

ANOVA: Single Factor

DESCRIPTION		Alpha 0.05						
<i>Group</i>	<i>Count</i>	<i>Sum</i>	<i>Mean</i>	<i>Variance</i>	<i>SS</i>	<i>Std Err</i>	<i>Lower</i>	<i>Upper</i>
CE	3	14.1	4.7	0.0183	0.0366	0.355985	3.879098	5.520902
PEF1	3	26.9	8.966666667	1.435733	2.871467	0.355985	8.145765	9.787569
CE+PEF2	3	211.3	70.43333333	0.043333	0.086667	0.355985	69.61243	71.25424
PEF1+PEF2	3	179.3	59.76666667	0.023333	0.046667	0.355985	58.94576	60.58757

ANOVA

<i>Sources</i>	<i>SS</i>	<i>df</i>	<i>MS</i>	<i>F</i>	<i>P value</i>	<i>Eta-sq</i>	<i>RMSSE</i>	<i>Omega Sq</i>
Btween Groups	10382.99	3	3460.995556	9103.691	1.81E-14	0.999707	55.08687	0.999561
Within Groups	3.0414	8	0.380175					
Total	10386.03	11	944.1843697					

SD

CE	0,135277
PEF1	1,198221
CE+PEF1	0,208167
PEF1+PEF2	0,152753

- Colour (420nm)

Total phenols (420nm)			
CE	PEF1	CE+PEF2	PEF1+PEF2
0.1061	0.1327	0.1394	0.1507
0.109	0.1166	0.1517	0.1661
0.101	0.1343	0.1453	0.1682

ANOVA: Single
Factor

DESCRIPTION					Alpha	0.05			
<i>Group</i>	<i>Count</i>	<i>Sum</i>	<i>Mean</i>	<i>Variance</i>	<i>SS</i>	<i>Std Err</i>	<i>Lower</i>	<i>Upper</i>	
CE	3	0.3161	0.105366667	1.64E-05	3.28E-05	0.004485	0.095024	0.115709	
PEF1	3	0.3836	0.127866667	9.58E-05	0.000192	0.004485	0.117524	0.138209	
CE+PEF2	3	0.4364	0.145466667	3.78E-05	7.57E-05	0.004485	0.135124	0.155809	
PEF1+PEF2	3	0.485	0.161666667	9.13E-05	0.000183	0.004485	0.151324	0.172009	

ANOVA

<i>Sources</i>	<i>SS</i>	<i>df</i>	<i>MS</i>	<i>F</i>	<i>P value</i>	<i>Eta-sq</i>	<i>RMSSE</i>	<i>Omega Sq</i>
	0.00524							
Between Groups	9	3	0.001749648	28.99247	0.00012	0.915769	3.108723	0.874971
	0.00048							
Within Groups	3	8	6.03483E-05					
	0.00573							
Total	2	11	0.000521066					

SD

CE	0,00405
PEF1	0,00979
CE+PEF1	0,006152
PEF1+PEF2	0,009555

- CIELab

Lightness

Control	PEF1	Control+PEF2	PEF1+PEF2
97.9602	92.3205	94.743	93.9959
97.9796	93.441	93.6777	93.4267
98.0871	93.5763	92.2619	92.4738

ANOVA: Single Factor

DESCRIPTION		Alpha 0.05						
<i>Group</i>	<i>Count</i>	<i>Sum</i>	<i>Mean</i>	<i>Variance</i>	<i>SS</i>	<i>Std Err</i>	<i>Lower</i>	<i>Upper</i>
CE	3	294.0269	98.00897	0.004673	0.009345	0.467305	96.93136018	99.08657315
PEF1	3	279.3378	93.1126	0.475143	0.950287	0.467305	92.03499352	94.19020648
CE+PEF2	3	280.6826	93.56087	1.549202	3.098404	0.467305	92.48326018	94.63847315
PEF1+PEF2	3	279.8964	93.2988	0.591466	1.182932	0.467305	92.22119352	94.37640648

ANOVA

<i>Sources</i>	<i>SS</i>	<i>df</i>	<i>MS</i>	<i>F</i>	<i>P value</i>	<i>Eta-sq</i>	<i>RMSSE</i>	<i>Omega Sq</i>
Between								
Groups	49.68747	3	16.56249	25.28158	0.000196	0.904586	2.902962691	0.858565172
Within Groups	5.240968	8	0.655121					
Total	54.92844	11	4.993494					

SD

CE	0,068357
PEF1	0,689306
CE+PEF1	1,244669
PEF1+PEF2	0,769068

a

ANOVA: Single Factor

DESCRIPTION		Alpha 0,05						
<i>Group</i>	<i>Count</i>	<i>Sum</i>	<i>Mean</i>	<i>Variance</i>	<i>SS</i>	<i>Std Err</i>	<i>Lower</i>	<i>Upper</i>
CE	3	-3,142	-1,04737	0,000219	0,000439	0,059872	-1,18543	-0,9093
PEF1	3	-1,495	-0,49833	0,01547	0,03094	0,059872	-0,6364	-0,36027
CE+PEF2	3	-2,126	-0,70893	0,021991	0,043982	0,059872	-0,847	-0,57087
PEF1+PEF2	3	-2,209	-0,73663	0,005336	0,010672	0,059872	-0,8747	-0,59857

ANOVA

<i>Sources</i>	<i>SS</i>	<i>df</i>	<i>MS</i>	<i>F</i>	<i>P value</i>	<i>Eta-sq</i>	<i>RMSSE</i>	<i>Omega Sq</i>
Between Groups	0,460827	3	0,153609	14,28385	0,001409	0,842679	2,182036	0,76857
Within Groups	0,086032	8	0,010754					
Total	0,54686	11	0,049715					

	<i>SD</i>
CE	0,0148086
PEF1	0,1243781
CE+PEF1	0,1482939
PEF1+PEF2	0,0730472

b

ANOVA: Single Factor

DESCRIPTION		Alpha 0,05						
<i>Group</i>	<i>Count</i>	<i>Sum</i>	<i>Mean</i>	<i>Variance</i>	<i>SS</i>	<i>Std Err</i>	<i>Lower</i>	<i>Upper</i>
CE	3	19,2489	6,4163	5,46E-05	0,000109	0,201932	5,950644	6,881956
PEF1	3	26,6874	8,8958	0,217928	0,435856	0,201932	8,430144	9,361456
CE+PEF2	3	27,4739	9,157967	0,186122	0,372244	0,201932	8,692311	9,623623
PEF1+PEF2	3	27,7604	9,253467	0,085214	0,170428	0,201932	8,787811	9,719123

ANOVA

<i>Sources</i>	<i>SS</i>	<i>df</i>	<i>MS</i>	<i>F</i>	<i>P value</i>	<i>Eta-sq</i>	<i>RMSSE</i>	<i>Omega Sq</i>
Between Groups	16,43996	3	5,479987	44,79689	2,4E-05	0,943817	3,864233	0,916313
Within Groups	0,978637	8	0,12233					
Total	17,4186	11	1,583509					

	<i>SD</i>
CE	0,00739
PEF1	0,466827
CE+PEF1	0,431419
PEF1+PEF2	0,291914